





HP LaserJet Professional P1100 Printer series

Service Manual

Copyright and License

© 2010 Copyright Hewlett-Packard
Development Company, L.P.

Reproduction, adaptation, or translation
without prior written permission is prohibited,
except as allowed under the copyright laws.

The information contained herein is subject
to change without notice.

The only warranties for HP products and
services are set forth in the express warranty
statements accompanying such products
and services. Nothing herein should be
construed as constituting an additional
warranty. HP shall not be liable for technical
or editorial errors or omissions contained
herein.

Part number: CE651-90953

Edition 1, 4/2010

Trademark Credits

Microsoft®, Windows®, Windows® XP, and
Windows Vista® are U.S. registered
trademarks of Microsoft Corporation.

Conventions used in this guide

 **TIP:** Tips provide helpful hints or shortcuts.

 **NOTE:** Notes provide important information to explain a concept or to complete a task.

 **CAUTION:** Cautions indicate procedures that you should follow to avoid losing data or damaging the product.

 **WARNING!** Warnings alert you to specific procedures that you should follow to avoid personal injury, catastrophic loss of data, or extensive damage to the product.

Table of contents

1 Theory of operation	1
Basic operation	2
Major product systems	2
Product block diagram	2
Sequence of operation	3
Normal sequence of operation	3
Formatter-control system	4
Sleep mode	4
Input/output	4
CPU	4
Memory	4
Firmware	5
Memory use	5
PJM overview	5
LEDM overview	5
ACL overview	5
Control panel	6
Wireless PCA	6
Engine-control system	7
Motors, fans, clutches, solenoids, switches, and sensors	8
DC controller operations	11
Fuser-control circuit	12
Fuser failure detection	13
Fuser temperature control	14
Fuser protective function	15
Pressure roller cleaning	15
Low-voltage power supply	16
Overcurrent/overvoltage protection	17
High-voltage power supply	18
Laser/scanner system	19
Laser failure detection	20
Image-formation system	21
Electrophotographic process	21
Image formation process	23

Latent-image formation stage	24
Primary charging	24
Laser beam exposure	24
Developing stage	25
Print cartridge	25
Transfer stage	26
Fusing stage	27
Cleaning stage	27
Pickup, feed, and delivery system	28
Photo sensors and switches	29
Input tray, main-input tray, or priority input slot	30
Jam detection	30
2 Removal and replacement	31
Introduction	32
Removal and replacement strategy	32
Electrostatic discharge	33
Required tools	33
Before performing service	34
After performing service	34
Post-service test	35
Print-quality test	35
Parts removal order	36
Pickup roller	37
Separation pad	38
Transfer roller	39
Covers	40
Input tray or main-input tray	40
Output bin tray extension	41
Front cover	42
Remove the front cover	42
Left cover	43
Remove the left cover	43
Right cover	46
Remove the right cover	46
Cartridge door	48
Remove the cartridge door	48
Face-down cover	50
Remove the face-down cover	50
Rear cover	52
Remove the rear cover	52
Main assemblies	54
Formatter PCA	54

Remove the formatter PCA	55
Wireless PCA	57
Remove the wireless PCA	57
Laser/scanner assembly	58
Remove the laser/scanner assembly	58
Reinstall the laser/scanner assembly	60
Pickup assembly	61
Remove the pickup assembly	61
Reinstall the pickup assembly	65
Fuser	67
Remove the fuser	67
Reinstall the fuser	71
Main motor	72
Remove the main motor	72
Reinstall the main-motor drive belt	76
Pickup solenoid	77
Remove the pickup solenoid	77
Engine controller PCA	80
Remove the engine controller PCA	80
Reinstall the engine controller PCA	84
3 Solve problems	87
Solve problems checklist	88
Troubleshooting process	91
Determine the problem source	91
Power subsystem	92
Power-on checks	92
Tools for troubleshooting	93
Individual component diagnostics	93
Engine diagnostics	93
Engine-test button	93
Components tests	94
Drum rotation functional check	94
Half self-test functional check	94
Diagrams	95
Plug/jack locations	95
Location of connectors	96
Locations of major components	97
General timing charts	99
General circuit diagram	100
Internal print-quality test pages	102
Cleaning page	102
Configuration page	102

Print-quality troubleshooting tools	103
Repetitive defect ruler	103
Interpret control-panel light patterns	103
Clear jams	107
Common causes of jams	107
Jam locations	108
Clear jams from the input tray	109
Clear jams from the output areas	111
Clear jams from inside the product	113
Solve repeated jams	114
Change jam recovery	114
Solve paper-handling problems	116
Solve image-quality problems	117
Image defect table	117
Light print or faded	117
Toner specks	117
Dropouts	118
Vertical lines	118
Gray background	118
Toner smear	118
Loose toner	119
Vertical repetitive defects	119
Misformed characters	119
Page skew	119
Curl or wave	120
Wrinkles or creases	120
Toner scatter outline	120
Moisture	121
Optimize and improve image quality	122
Change print density	122
Clean the product	123
Clean the pickup roller	123
Clean the paper path	124
Clean the print-cartridge area	126
Clean the exterior	128
Solve performance problems	129
Solve connectivity problems	130
Solve direct-connect problems	130
Solve wireless problems	130
Service mode functions	132
Product resets	132
Product updates	133

4 Parts and diagrams	135
Order parts by authorized service providers	136
Order parts, accessories, and supplies	136
Related documentation and software	136
Supplies part numbers	136
Customer self repair parts	137
Service parts	137
Whole-unit replacement part numbers	137
How to use the parts lists and diagrams	138
Assembly locations	139
Base product	139
Covers	140
Base model	140
Wireless model	142
Internal assemblies	144
Internal assemblies (1 of 3)	144
Internal assemblies (2 of 3)	146
Internal assemblies (3 of 3)	148
PCAs	150
Alphabetical parts list	152
Numerical parts list	155
Appendix A Service and support	159
Hewlett-Packard limited warranty statement	160
HP's Premium Protection Warranty: LaserJet print cartridge limited warranty statement	161
End User License Agreement	162
Customer self-repair warranty service	164
Customer support	164
Repack the product	165
Service information form	166
Appendix B Specifications	167
Physical specifications	168
Power consumption	168
Acoustic specifications	168
Environmental specifications	169
Appendix C Regulatory information	171
FCC regulations	172
Declaration of conformity (base models)	173
Declaration of conformity (wireless models)	174
Certificate of Volatility	175
Safety statements	177

Laser safety	177
Canadian DOC regulations	177
VCCI statement (Japan)	177
Power cord instructions	177
Power cord statement (Japan)	177
EMC statement (Korea)	177
Laser statement for Finland	178
GS statement (Germany)	178
Substances Table (China)	179
Additional statements for wireless products	180
FCC compliance statement—United States	180
Australia statement	180
Brazil ANATEL statement	180
Canadian statements	180
European Union regulatory notice	180
Notice for use in France	181
Notice for use in Russia	181
Korean statement	181
Taiwan statement	181
Index	183

List of tables

Table 1-1	Sequence of operation	3
Table 1-2	Motors	8
Table 1-3	Solenoids and clutches	9
Table 1-4	Switches	9
Table 1-5	Sensors	10
Table 1-6	DC controller controlled components	11
Table 1-7	Photo sensors, motor, and solenoid	29
Table 3-1	Basic problem solving	88
Table 3-2	Status-light legend	103
Table 3-3	Control-panel light patterns	104
Table 4-1	Order parts, accessories, and supplies	136
Table 4-2	Related documentation and software	136
Table 4-3	Supplies part numbers	136
Table 4-4	Customer replaceable units (CRU) kit part numbers	137
Table 4-5	Whole-unit replacement part numbers	137
Table 4-6	Base product	139
Table 4-7	Base model	141
Table 4-8	Wireless model	143
Table 4-9	Internal assemblies (1 of 3)	145
Table 4-10	Internal assemblies (2 of 3)	147
Table 4-11	Internal assemblies (3 of 3)	149
Table 4-12	PCAs	151
Table 4-13	Alphabetical parts list	152
Table 4-14	Numerical parts list	155
Table B-1	Physical specifications ¹	168
Table B-2	HP LaserJet Professional P1100 Printer series (average in watts) ¹²³	168
Table B-3	HP LaserJet Professional P1100 Printer series ¹²	168
Table B-4	Environmental specifications	169

List of figures

Figure 1-1	Product block diagram	2
Figure 1-2	Engine-control system	7
Figure 1-3	Motors	8
Figure 1-4	Solenoids and clutches	9
Figure 1-5	Switches	9
Figure 1-6	Sensors	10
Figure 1-7	DC controller block diagram	11
Figure 1-8	Fuser control circuit	12
Figure 1-9	Fuser-heater control circuit	14
Figure 1-10	Low-voltage power supply (LVPS)	16
Figure 1-11	High-voltage power supply	18
Figure 1-12	Laser/scanner system	19
Figure 1-13	Electrophotographic process block diagram (1 of 2)	21
Figure 1-14	Electrophotographic process block diagram (2 of 2)	22
Figure 1-15	Image formation process	23
Figure 1-16	Primary charging	24
Figure 1-17	Laser beam exposure	24
Figure 1-18	Print cartridge	25
Figure 1-19	Transfer	26
Figure 1-20	Separation	26
Figure 1-21	Fusing	27
Figure 1-22	Drum cleaning	27
Figure 1-23	Pickup, feed, and delivery system block diagram	28
Figure 1-24	Photo sensors, motor, and solenoid	29
Figure 2-1	Phillips and pozidrive screwdriver comparison	33
Figure 2-2	Parts removal order	36
Figure 2-3	Remove the pickup roller (1 of 2)	37
Figure 2-4	Remove the pickup roller (2 of 2)	37
Figure 2-5	Remove the separation pad assembly	38
Figure 2-6	Remove the transfer roller	39
Figure 2-7	Remove the tray	40
Figure 2-8	Remove the output bin tray extension	41
Figure 2-9	Remove the front cover	42
Figure 2-10	Remove the left cover (1 of 5)	43

Figure 2-11	Remove the left cover (2 of 5)	44
Figure 2-12	Remove the left cover (3 of 5)	44
Figure 2-13	Remove the left cover (4 of 5)	45
Figure 2-14	Remove the left cover (5 of 5)	45
Figure 2-15	Remove the right cover (1 of 3)	46
Figure 2-16	Remove the right cover (2 of 3)	46
Figure 2-17	Remove the right cover (3 of 3)	47
Figure 2-18	Remove the cartridge door (1 of 2)	48
Figure 2-19	Remove the cartridge door (2 of 2)	49
Figure 2-20	Remove the face-down cover (1 of 2)	50
Figure 2-21	Remove the face-down cover (2 of 2)	51
Figure 2-22	Remove the rear cover (1 of 2)	52
Figure 2-23	Remove the rear cover (2 of 2)	53
Figure 2-24	Remove the formatter PCA (HP LaserJet Professional P1100 Printer series; 1 of 4)	55
Figure 2-25	Remove the formatter PCA (HP LaserJet Professional P1100w Printer series; 2 of 4)	55
Figure 2-26	Remove the formatter PCA (HP LaserJet Professional P1100 Printer series; 3 of 4)	56
Figure 2-27	Remove the formatter PCA (HP LaserJet Professional P1100w Printer series; 4 of 4)	56
Figure 2-28	Remove the wireless PCA	57
Figure 2-29	Remove the laser/scanner assembly (1 of 4)	58
Figure 2-30	Remove the laser/scanner assembly (2 of 4)	59
Figure 2-31	Remove the laser/scanner assembly (3 of 4)	59
Figure 2-32	Remove the laser/scanner assembly (4 of 4)	60
Figure 2-33	Reinstall the laser/scanner assembly	60
Figure 2-34	Remove the pickup assembly (1 of 7)	61
Figure 2-35	Remove the pickup assembly (2 of 7)	62
Figure 2-36	Remove the pickup assembly (3 of 7)	62
Figure 2-37	Remove the pickup assembly (4 of 7)	63
Figure 2-38	Remove the pickup assembly (5 of 7)	63
Figure 2-39	Remove the pickup assembly (6 of 7)	64
Figure 2-40	Remove the pickup assembly (7 of 7)	64
Figure 2-41	Reinstall the pickup assembly (1 of 4; correct ground spring position)	65
Figure 2-42	Reinstall the pickup assembly (2 of 4; incorrect ground spring position)	65
Figure 2-43	Reinstall the pickup assembly (3 of 4; lift plate in raised position)	66
Figure 2-44	Reinstall the pickup assembly (4 of 4; lift plate in lowered position)	66
Figure 2-45	Remove the fuser (1 of 7)	67
Figure 2-46	Remove the fuser (2 of 7)	68
Figure 2-47	Remove the fuser (3 of 7)	68
Figure 2-48	Remove the fuser (4 of 7)	69
Figure 2-49	Remove the fuser (5 of 7)	69
Figure 2-50	Remove the fuser (6 of 7)	70
Figure 2-51	Remove the fuser (7 of 7)	70
Figure 2-52	Reinstall the fuser; correct wire harness installation	71
Figure 2-53	Reinstall the fuser; incorrect wire harness installation	71
Figure 2-54	Remove the main motor (1 of 7)	72

Figure 2-55	Remove the main motor (2 of 7)	73
Figure 2-56	Remove the main motor (3 of 7)	73
Figure 2-57	Remove the main motor (4 of 7)	74
Figure 2-58	Remove the main motor (5 of 7)	74
Figure 2-59	Remove the main motor (6 of 7)	75
Figure 2-60	Remove the main motor (7 of 7)	75
Figure 2-61	Main-motor drive belt: correctly installed	76
Figure 2-62	Main-motor drive belt: incorrectly installed	76
Figure 2-63	Remove the pickup solenoid (1 of 5)	77
Figure 2-64	Remove the pickup solenoid (2 of 5)	78
Figure 2-65	Remove the pickup solenoid (3 of 5)	78
Figure 2-66	Remove the pickup solenoid (4 of 5)	79
Figure 2-67	Remove the pickup solenoid (5 of 5)	79
Figure 2-68	Remove the engine controller PCA (1 of 8)	80
Figure 2-69	Remove the engine controller PCA (2 of 8)	81
Figure 2-70	Remove the engine controller PCA (3 of 8)	81
Figure 2-71	Remove the engine controller PCA (4 of 8)	82
Figure 2-72	Remove the engine controller PCA (5 of 8)	82
Figure 2-73	Remove the engine controller PCA (6 of 8)	83
Figure 2-74	Remove the engine controller PCA (7 of 8)	83
Figure 2-75	Remove the engine controller PCA (8 of 8)	84
Figure 2-76	Reinstall the engine controller PCA (1 of 4)	84
Figure 2-77	Reinstall the engine controller PCA (2 of 4)	85
Figure 2-78	Reinstall the engine controller PCA (3 of 4)	85
Figure 2-79	Reinstall the engine controller PCA (4 of 4)	86
Figure 3-1	Sample engine test page	93
Figure 3-2	Plug/jack locations	95
Figure 3-3	Engine controller PCA connectors	96
Figure 3-4	External view	97
Figure 3-5	Cross section view	98
Figure 3-6	General timing diagram	99
Figure 3-7	Circuit diagram; HP LaserJet Professional P1100 Printer series	100
Figure 3-8	Circuit diagram; HP LaserJet Professional P1100w Printer series	101
Figure 4-1	Base product	139
Figure 4-2	Base model	140
Figure 4-3	Wireless model	142
Figure 4-4	Internal assemblies (1 of 3)	144
Figure 4-5	Internal assemblies (2 of 3)	146
Figure 4-6	Internal assemblies (3 of 3)	148
Figure 4-7	PCAs	150

1 Theory of operation

- [Basic operation](#)
- [Formatter-control system](#)
- [Engine-control system](#)
- [Image-formation system](#)
- [Pickup, feed, and delivery system](#)
- [Input tray, main-input tray, or priority input slot](#)

Basic operation

Major product systems

The product contains the following major systems:

- Engine-control system
- Laser/scanner system
- Image-formation system
- Pickup-and-feed system

Product block diagram

Figure 1-1 Product block diagram

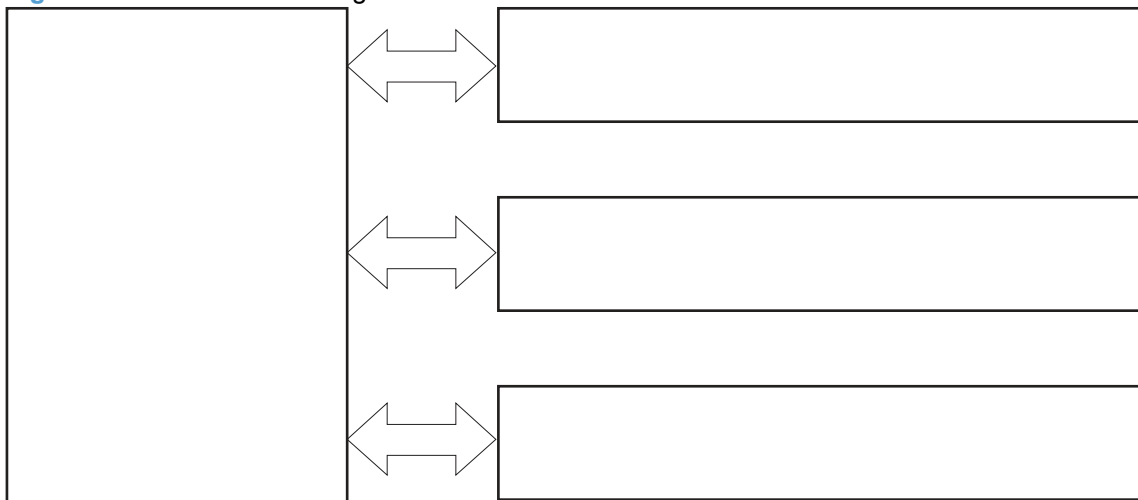

Sequence of operation

The DC controller in the engine-control system controls the operational sequences of the product. The table below describes durations and operations for each period of a print operation from when the product is turned on until the motor stops rotating.

Normal sequence of operation

Table 1-1 Sequence of operation

Name	Timing	Purpose
WAIT	From the time the power switch is turned on, the door is closed or the product exits Sleep mode until the product gets ready for a print operation.	Brings the product to the ready state. The product performs the following during the operations: <ul style="list-style-type: none"> • Detects the print cartridge • Heats the fuser film in the fuser • Rotates, and then stops, the main motor
STBY (standby)	From the end of the WAIT or LSTR period until either a print command is sent or the power switch is turned off.	Maintains the product in printable condition. The product performs the following during the operation: <ul style="list-style-type: none"> • Enters Auto-Off mode if the Auto-Off command is received
INTR (initial rotation)	From the time a print command is received until the paper is picked up.	The product performs the following during the operations: <ul style="list-style-type: none"> • Drives the main motor • Activates the high-voltage power supply • Activates the laser/scanner • Warms the fuser heater
PRINT	From the end of the INTR period until the last sheet completes the fuser operation.	Forms the image on the photosensitive drum based on the VIDEO signals from the formatter. Transfers and fuses the toner image to the paper.
LSTR (last rotation)	From the end of the PRINT period until the main motor stops rotating.	Moves the last printed sheet out of the product. The product performs the following during the operations: <ul style="list-style-type: none"> • Stops the main motor • Deactivates the high-voltage power supply • Deactivates the laser/scanner • Deactivates the fuser heater <p>The product enters the INTR period as the LSTR period is completed, if the formatter sends another print command.</p>

Formatter-control system

The formatter is responsible for the following procedures:

- Controlling sleep mode
- Receiving and processing print data from the various product interfaces
- Monitoring control-panel functions and relaying product-status information (through the control panel and the network or bidirectional interface)
- Developing and coordinating data placement and timing with the DC controller PCA
- Storing font information
- Communicating with the host computer through the network or the bidirectional interface

The formatter receives a print job from the network or bidirectional interface and separates it into image information and instructions that control the printing process. The DC controller PCA synchronizes the image-formation system with the paper-input and -output systems, and then signals the formatter to send the print-image data.

Sleep mode

 **NOTE:** This product uses an Auto-Off feature for sleep mode.

After a user-specified time, the Auto-Off feature automatically conserves electricity by substantially reducing power consumption when the product is not printing. After a user-specified time, the product automatically reduces its power consumption (Auto-Off). The product returns to the ready state when a button is pressed, a print job is received, or a door is opened. When the product is in Auto-Off mode, the control-panel LEDs and the power button backlight LED are off.

 **NOTE:** Although the product lights are off in Auto-Off mode, the product functions normally when it receives a print job.

Input/output

The product receives print data primarily from the following:

- Hi-Speed USB 2.0 port
- 802.11b/g wireless networking (wireless models only)

CPU

The formatter incorporates a 400 MHz Helium processor.

Memory

The random access memory (RAM) on the formatter PCA contains the page, I/O buffers, and the font storage area. RAM stores printing and font information received from the host system, and can also serve to temporarily store a full page of print-image data before the data is sent to the print engine.

Firmware

- HP LaserJet Professional P1100 Printer series
 - The product has 2 MB of Synchronous DRAM, which is used for run-time firmware imaging and specific print job information for the print job.
- HP LaserJet Professional P1100w Printer series
 - The product has 8 MB of Synchronous DRAM, which is used for run-time firmware imaging and specific print job information for the print job.

Memory use

- HP LaserJet Professional P1100 Printer series
 - The product has a 2 KB EEPROM and 64 MB of NAND Flash Memory, which is used for product configuration information and printer driver firmware.
- HP LaserJet Professional P1100w Printer series
 - The product has a 8 KB EEPROM and 64 MB of NAND Flash Memory, which is used for product configuration information and printer driver firmware.

PJL overview

The printer job language (PJL) is an integral part of configuration, in addition to the standard printer command language (PCL). With standard cabling, the product can use PJL to perform a variety of functions such as these:

- Two-way communication with the host computer through a network connection or a USB connection. The product can inform the host about such things as the control-panel settings, and the control-panel settings can be changed from the host.
- Dynamic I/O switching. The product uses this switching to be configured with a host on each I/O. The product can receive data from more than one I/O simultaneously, until the I/O buffer is full. This can occur even when the product is offline.
- Context-sensitive switching. The product can automatically recognize the personality (PS or PCL) of each job and configure itself to serve that personality.
- Isolation of print environment settings from one print job to the next. For example, if a print job is sent to the product in landscape mode, the subsequent print jobs print in landscape mode only if they are formatted for landscape printing.

LEDM overview

 **NOTE:** HP LaserJet Professional P1100w Printer series

The low-end data model (LEDM) provides one consistent data representation method and defines the dynamic and capabilities tickets shared between clients and devices, as well as the access protocol, event, security, and discovery methods.

ACL overview

The advanced control language (ACL) is a language that supports product control and firmware downloads in products that support both PJL/PCL and host-based printing. Each sequence of ACL

commands must be preceded by a unified exit command (UEL) and an @PJL ENTER LANGUAGE=ACL command. The ACL sequence is always followed by a UEL. Any number of commands can be placed between the UELs. The only exception to these rules is the download command. If a firmware download is done, the download command must be the last command in the sequence. It will not be followed by a UEL.

The firmware searches for the UEL sequence when parsing commands. However, while downloading binary data such as host-based code or NVRAM data the firmware suspends UEL parsing. To handle hosts that “disappear” during binary sequences, the firmware times out all ACL command sessions. If a timeout occurs during a non-download command sequence, it is treated as the receipt of a UEL. If a timeout occurs during firmware download the product resets.

Control panel

The formatter sends and receives product status and command data to and from the control-panel PCA.

Wireless PCA

 **NOTE:** Wireless models only.

The wireless PCA controls the wireless function of the product

Engine-control system

The engine-control system coordinates all product functions, according to commands that the formatter sends. The engine-control system drives the laser/scanner system, the image-formation system, and the pickup/feed/delivery system.

The engine control system contains the following major components:

- Engine-control unit (ECU)
 - DC controller
 - Low-voltage power supply
- High-voltage power supply
- Fuser control

Figure 1-2 Engine-control system

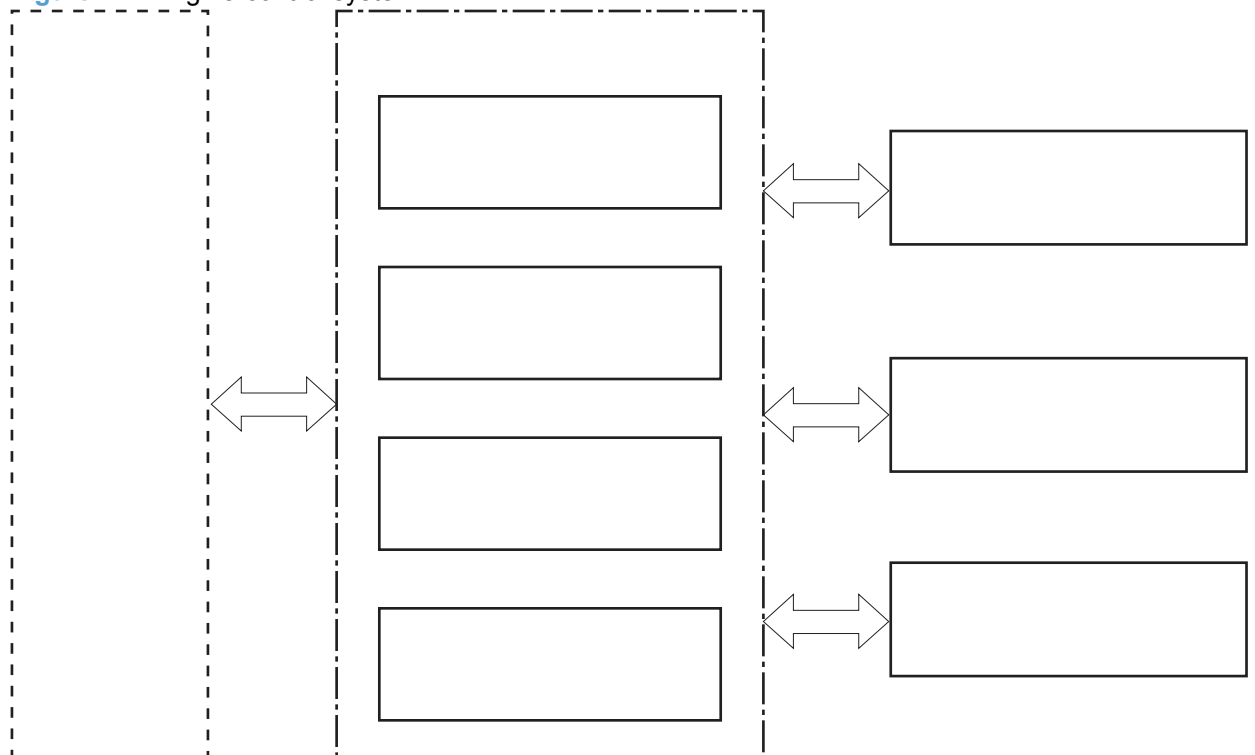

Motors, fans, clutches, solenoids, switches, and sensors

Figure 1-3 Motors

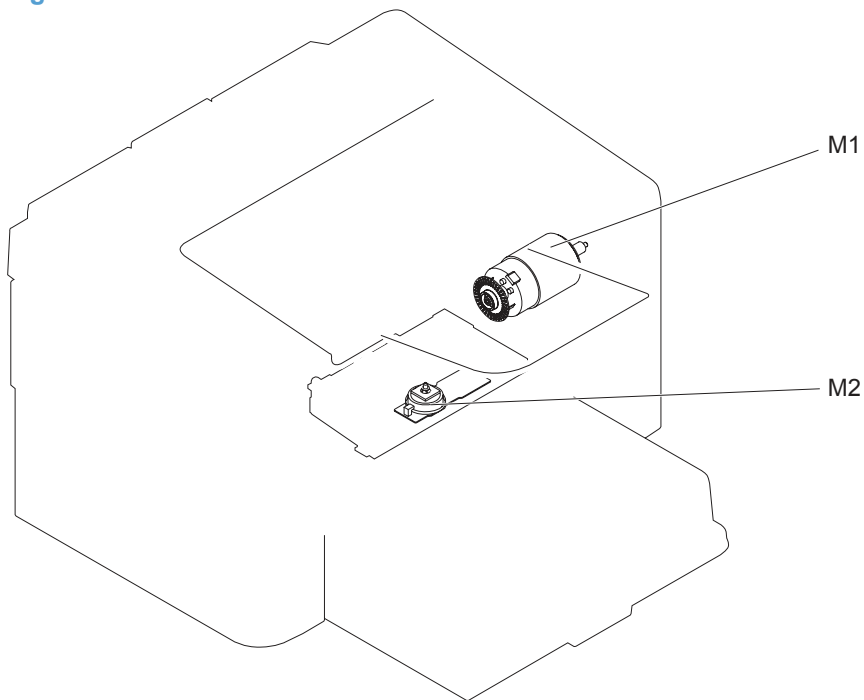

Table 1-2 Motors

Description	Components driven
Main motor (M1)	<ul style="list-style-type: none">• Pickup roller• Feed roller• Photosensitive drum• Developing roller• Pressure roller• Delivery roller
Scanner motor (M2)	<ul style="list-style-type: none">• Scanner mirror

Figure 1-4 Solenoids and clutches

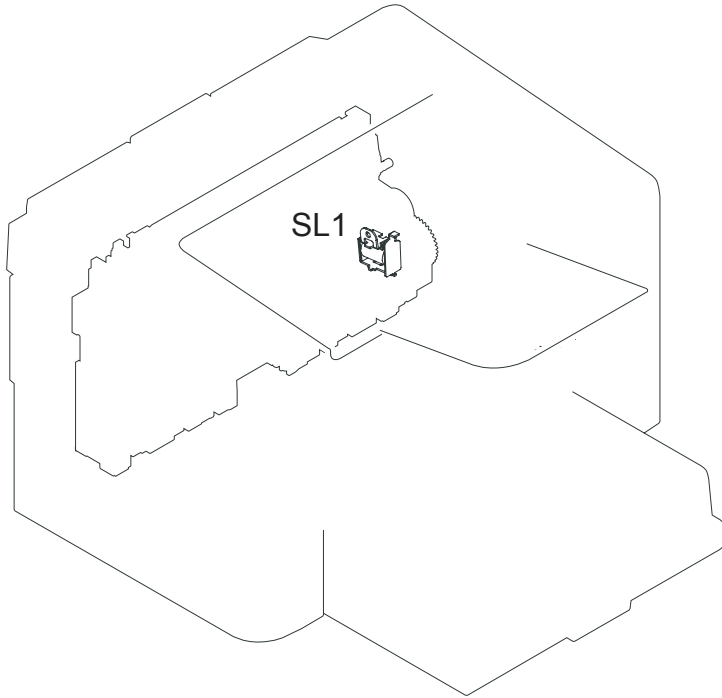

Table 1-3 Solenoids and clutches

Item	Description
SL1	Pickup solenoid

Figure 1-5 Switches

Table 1-4 Switches

Item	Description
SW501	Cartridge-door switch
SW502	Power switch; not shown

Figure 1-6 Sensors

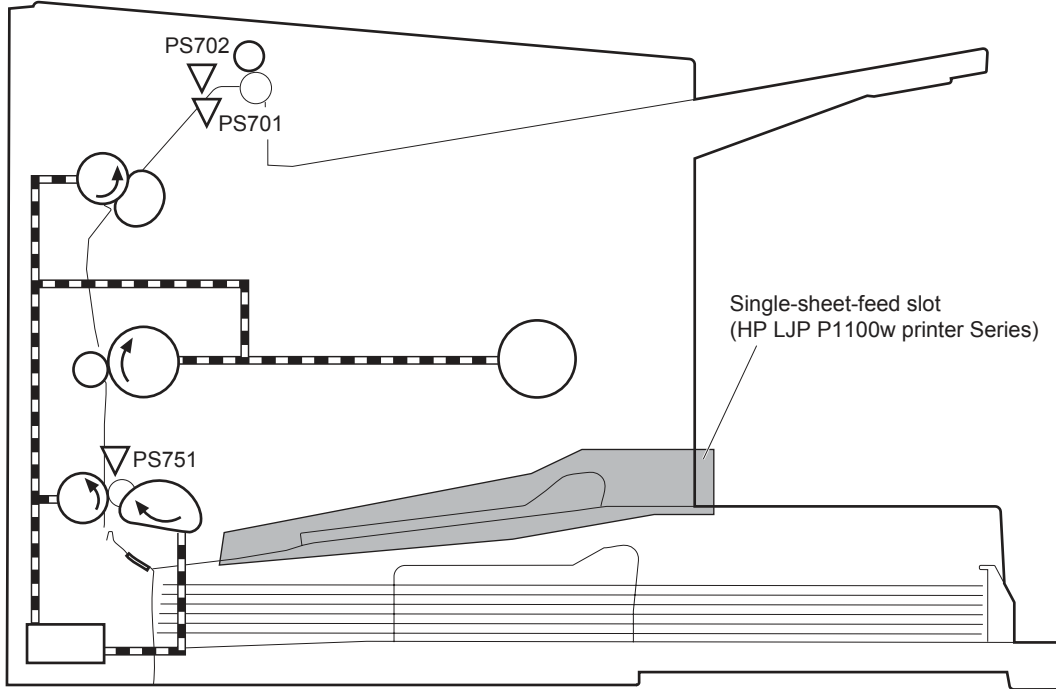

Table 1-5 Sensors

Item	Description
PS701	Fuser delivery sensor
PS702	Media width sensor
PS751	Top-of-Page (TOP) sensor
PS901	Main-motor rotation-number sensor; not shown

DC controller operations

The DC controller controls the operational sequences of the product systems.

Figure 1-7 DC controller block diagram

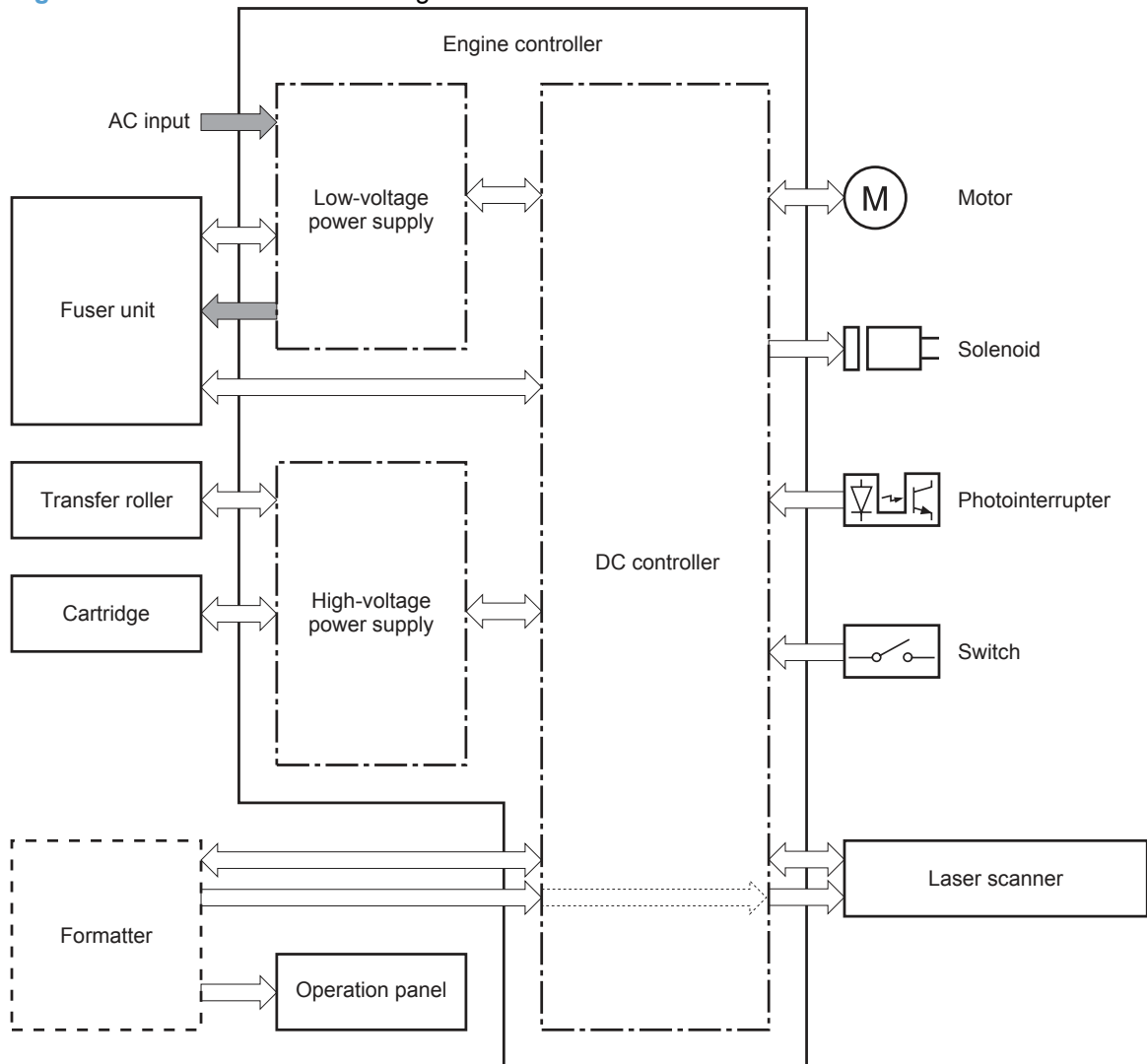

Table 1-6 DC controller controlled components

Component	Designator	Description
Motor	M1	Main motor
	M2	Scanner motor
Solenoid	SL1	Pickup solenoid
Photointerrupter	PS701	Fuser delivery sensor
	PS702	Media width sensor
	PS751	Top-of-Page (TOP) sensor
	PS901	Main-motor rotation-number sensor

Table 1-6 DC controller controlled components (continued)

Component	Designator	Description
Switch	SW501	Cartridge-door switch
	SW502	Power switch

Fuser-control circuit

The fuser-control circuit monitors and controls the temperature in the fuser. The product uses on-demand fusing. The fuser-control circuit consists of the following major components:

- Fuser heater (H1); heats the fusing film
- Thermistor (TH1); detects the fuser temperature (contact type)
- Thermal fuse (FU1); prevents abnormal temperature rise in the fuser (contact type)

Figure 1-8 Fuser control circuit

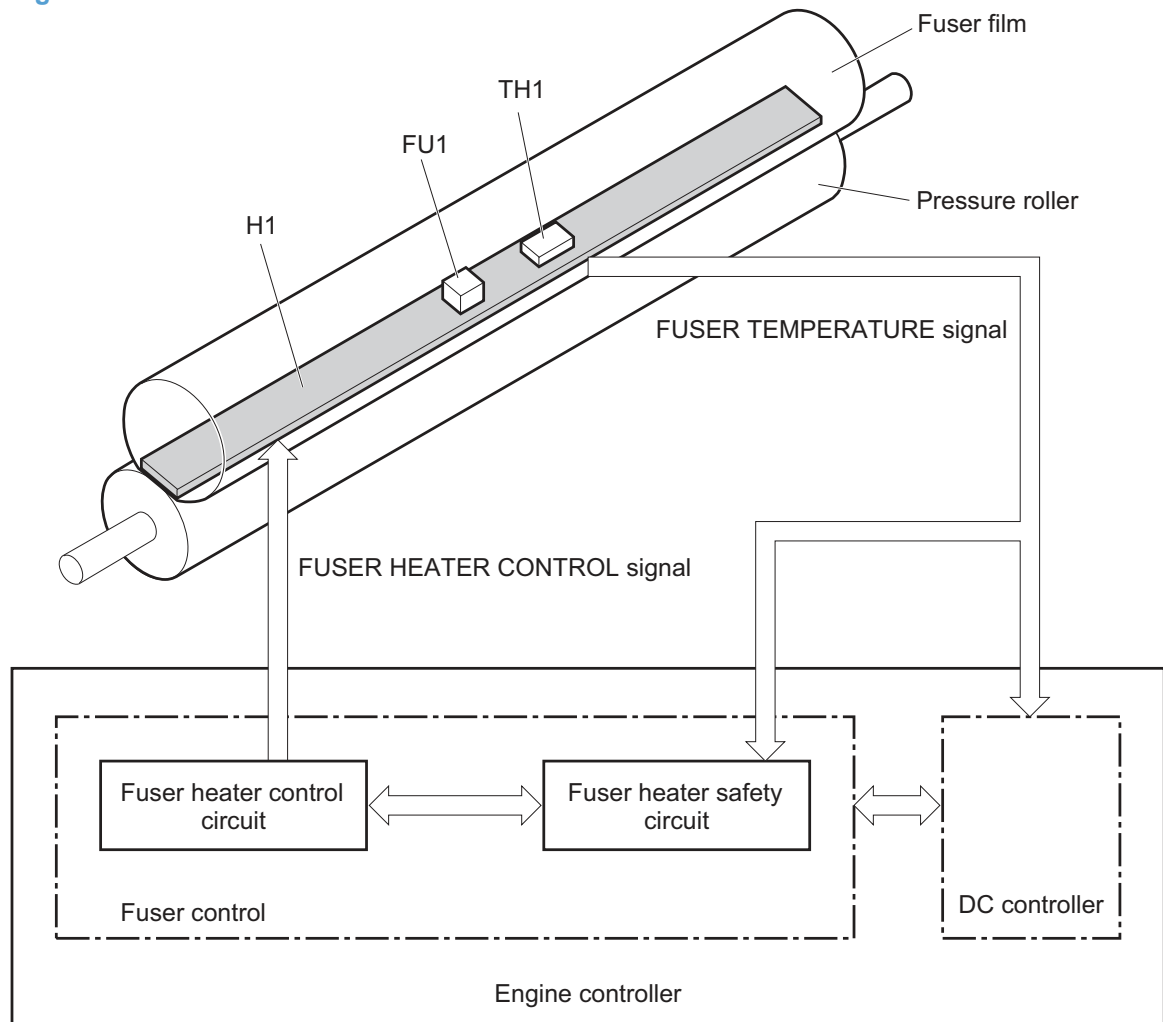

Fuser failure detection

The DC controller determines a fuser unit failure, releases the relay to interrupt power supply to the fuser heater, and notifies the formatter of a failure state when it encounters the following conditions:

- Start up failure
 - If the main thermistor does not detect a specified temperature during the start up process of the heater in the wait period.
 - If the main thermistor does not detect a specified temperature during the heater temperature control in the initial rotation period.
- Abnormal low temperature
 - If the main thermistor detects an abnormal low temperature of the fuser unit during the printing operation.
- Abnormal high temperature
 - If the main thermistor detects an abnormal high temperature of the fuser unit.
- Frequency detection circuit failure
 - If a specified frequency of the FREQUENCY signal is not detected within a specified period after the product is turned on.

Fuser temperature control

The fuser temperature control maintains the temperature of the fuser heater at its targeted temperature.

The DC controller monitors the FIXING TEMPERATURE (FSRTH) signals and sends the FIXING HEATER CONTROL (FSRD) signal according to the detected temperature. The fuser heater control circuit controls the fuser heater depending on the signal so that the heater remains at the targeted temperature.

Figure 1-9 Fuser-heater control circuit

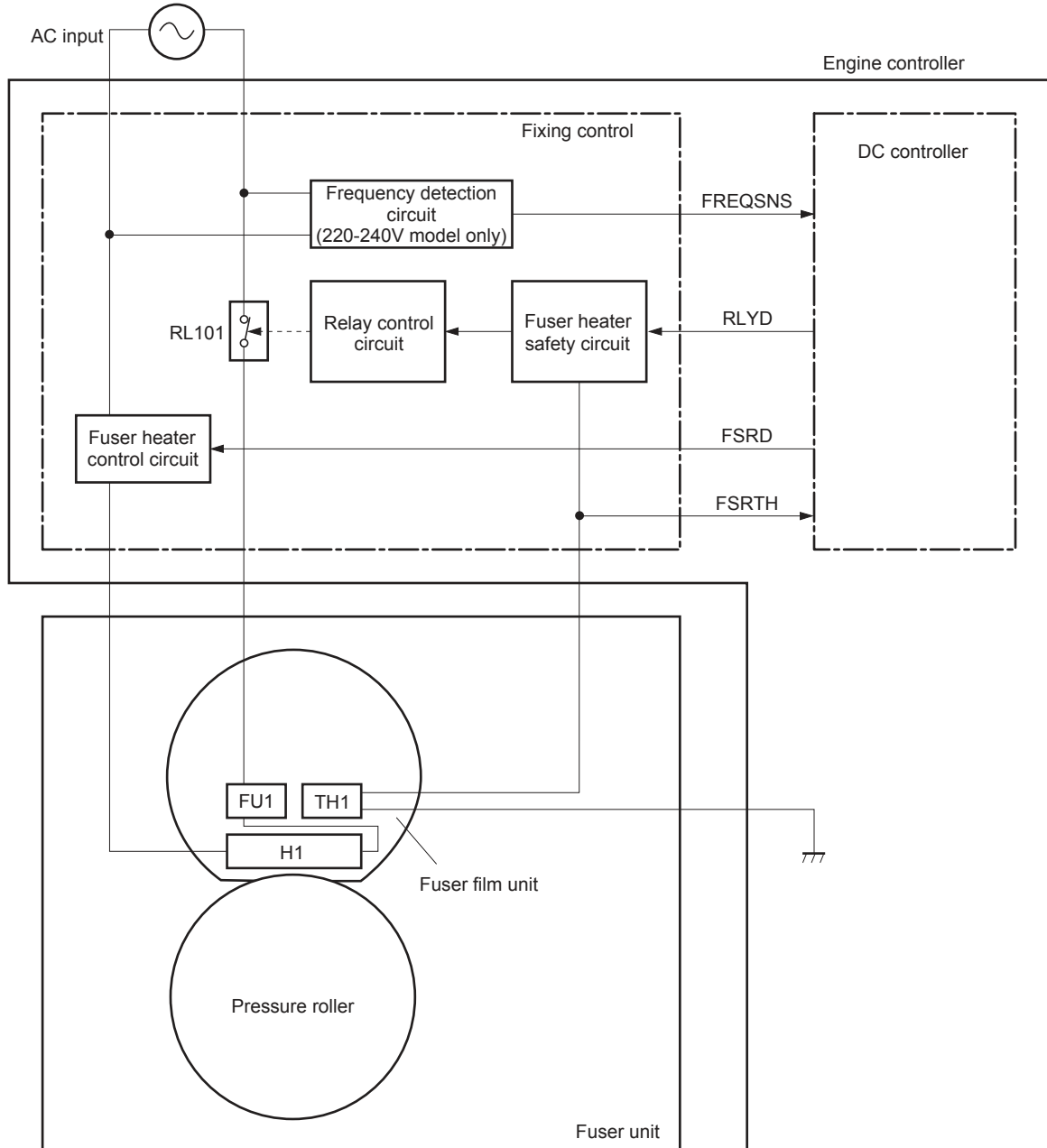

Fuser protective function

The protective function detects an abnormal temperature rise of the fuser unit and interrupts power supply to the fuser heater.

The following three protective components prevent an abnormal temperature rise of the fuser heater:

- DC controller
 - The DC controller interrupts power supply to the fuser heater when it detects an abnormal temperature of the fuser heater.
- Fuser heater safety circuit
 - The fuser heater safety circuit interrupts power supply to the fuser heater when the detected temperature of the main thermistor is abnormal.
- Thermal fuse
 - The contact of the thermal fuse is broken to interrupt power supply to the fuser heater when the thermal fuse detects an abnormal temperature of the fuser heater.

Pressure roller cleaning

The pressure roller cleaning process is initiated by the formatter. The process removes toner that has accumulated on the pressure roller by transferring it to a sheet of paper.

- The product feeds a sheet of paper after receiving the cleaning command from the formatter.
- Main motor rotation is stopped when the trailing edge of the paper passes through the transfer roller.
- The main motor rotation is repeatedly started and then stopped. The fuser heater is turned on and then off at the same interval as main motor rotation.
- Toner adhered to the pressure roller is fused to the paper.
- The paper is ejected from the product.

Low-voltage power supply

The low-voltage power supply (LVPS) converts ac input voltage to dc voltage. The LVPS has two fuses on the PCA. The LVPS 24 V output is interrupted to the fuser and the high-voltage power supply if the cartridge-door interlock switch (SW501) is in the off position (cover open).

WARNING! The product power switch only interrupts dc voltage from the LVPS. The ac voltage is present in the product when the power cord is plugged into a power receptacle and the power switch is in the off position. You must unplug the product power cord before servicing the product.

Figure 1-10 Low-voltage power supply (LVPS)

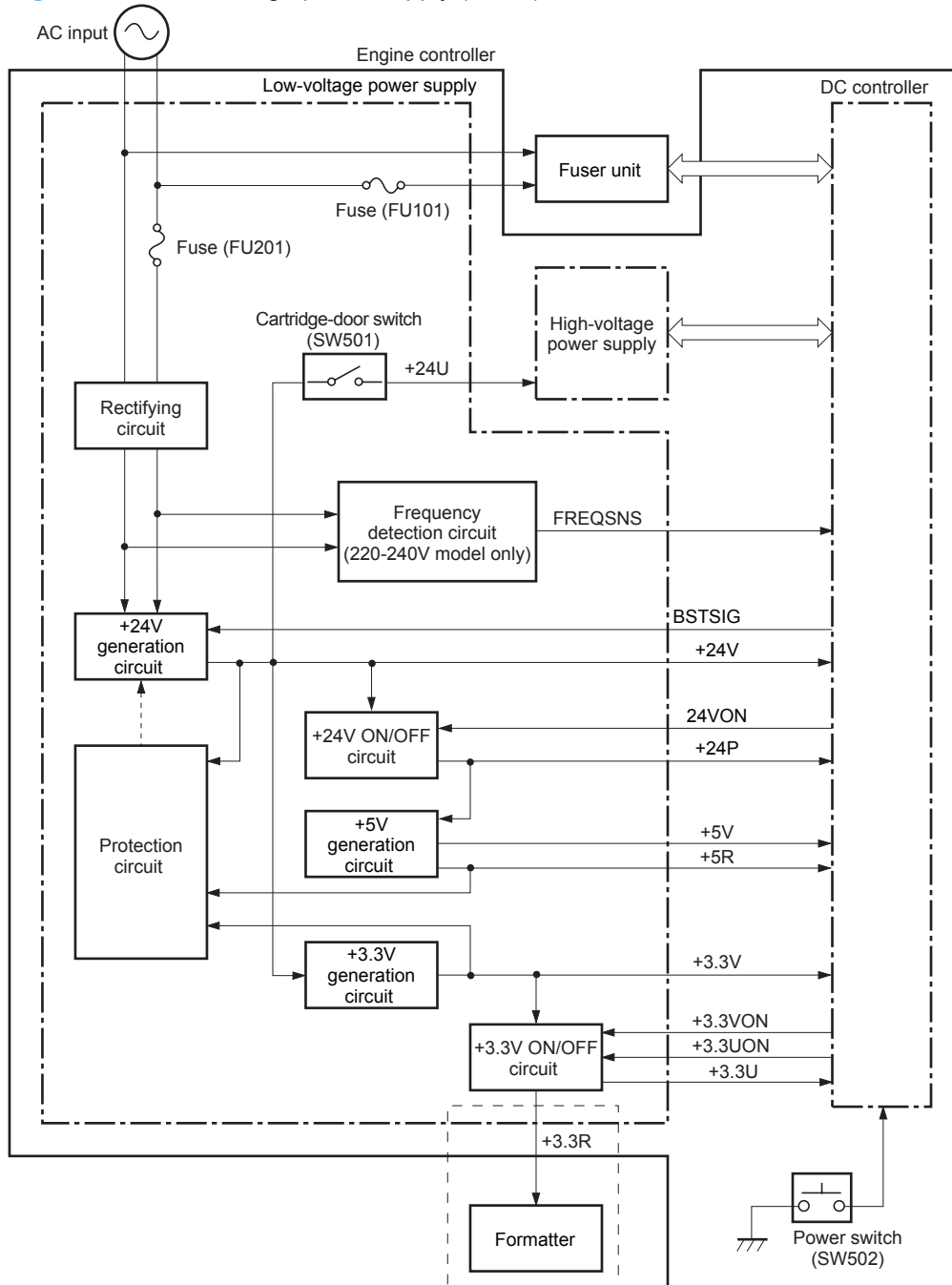

Overcurrent/overvoltage protection

The low-voltage power supply has a protective function against overcurrent and overvoltage to prevent failures in the power supply circuit. If an overcurrent or overvoltage condition occurs, the system automatically cuts off the output voltage.

If the dc power is not being supplied from the low-voltage power supply, the protective function might be running. In such case, turn off the power switch and unplug the power cord. Do not plug in the power cord or turn on the power switch again until the cause is found.

WARNING! If you believe the overcurrent or overvoltage protection circuits have been activated, do not plug in the product power cord or turn on the product power until the cause of the failure is found and corrected.

In addition, two fuses in the low-voltage power supply protect against overcurrent. If overcurrent flows into the ac line, the fuses melt and cut off the power distribution.

High-voltage power supply

The high-voltage power supply (HVPS) applies biases to the following components:

- Primary charging roller
- Developing roller
- Transfer roller

Figure 1-11 High-voltage power supply
Engine controller

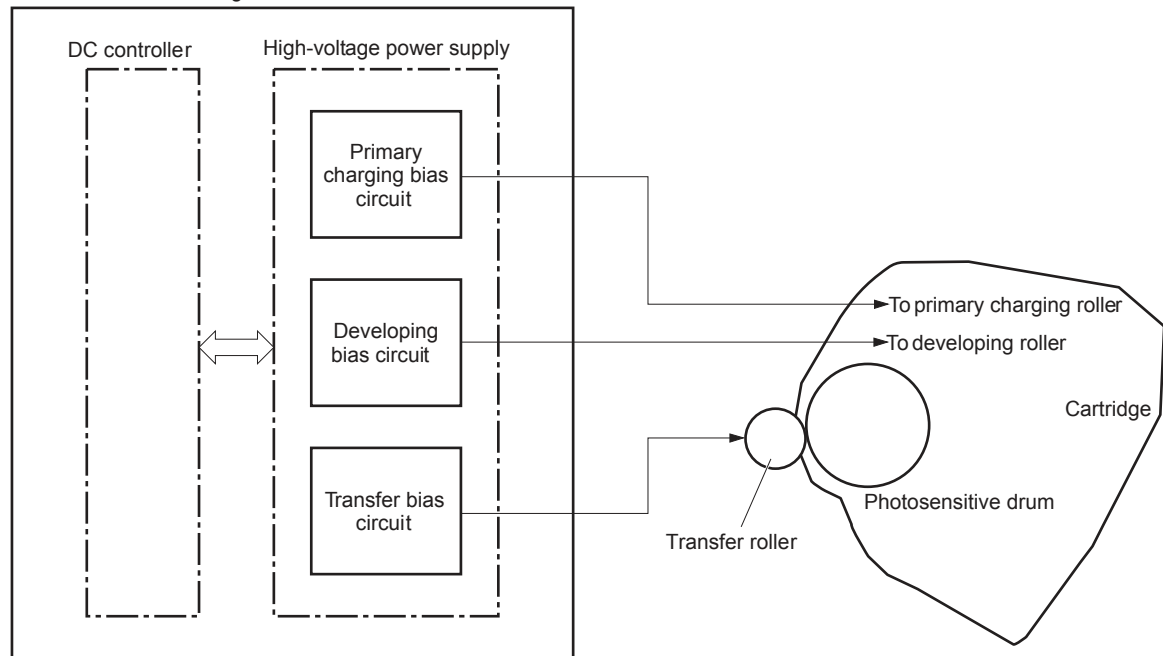

Laser/scanner system

The laser/scanner system receives VIDEO signals from the ECU and formatter and converts the signals into latent images on the photosensitive drum.

The main components of the laser/scanner are the laser unit and the scanner motor unit. The DC controller sends signals to the laser/scanner to control the functions of these components.

Figure 1-12 Laser/scanner system

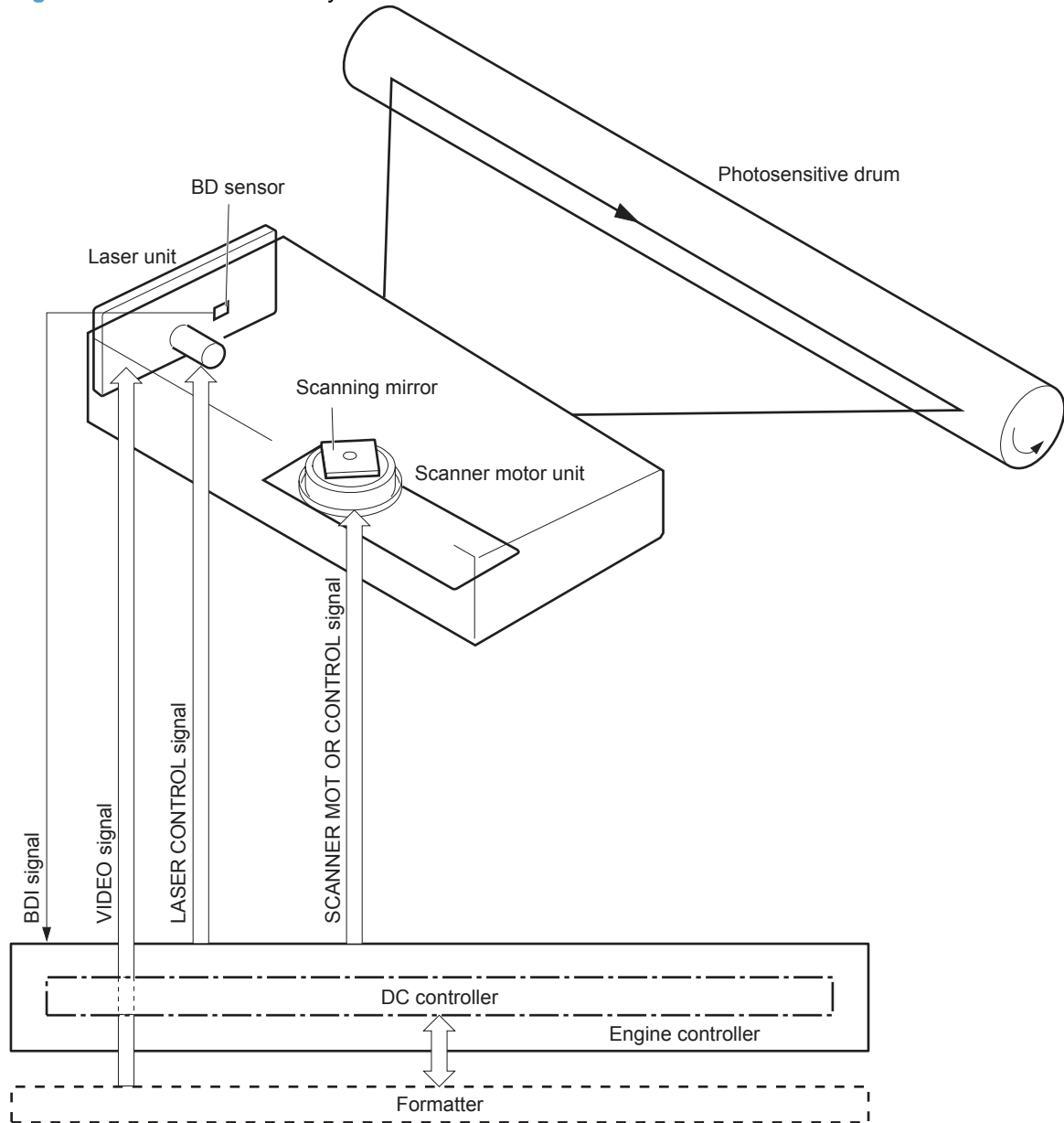

Laser failure detection

The DC controller determines an optical unit failure and notifies the formatter, if the laser/scanner encounters the following conditions:

- The scanner motor does not reach a specified rotation within a specified period of the scanner motor start up.
- The rotation of the scanner motor is out of specified range for a specified period during the scanner motor drive.
- The BD interval is out of a specified value during a print operation.

Image-formation system

Electrophotographic process

The electrophotographic process forms an image on the paper. Following are the major components used in the process:

- Print cartridge
- Transfer roller
- Fuser
- Laser/scanner
- High-voltage power supply

The DC controller uses the laser/scanner and HVPS to form the toner image on the photosensitive drum. The image is transferred to the paper and then fused onto the paper.

Figure 1-13 Electrophotographic process block diagram (1 of 2)

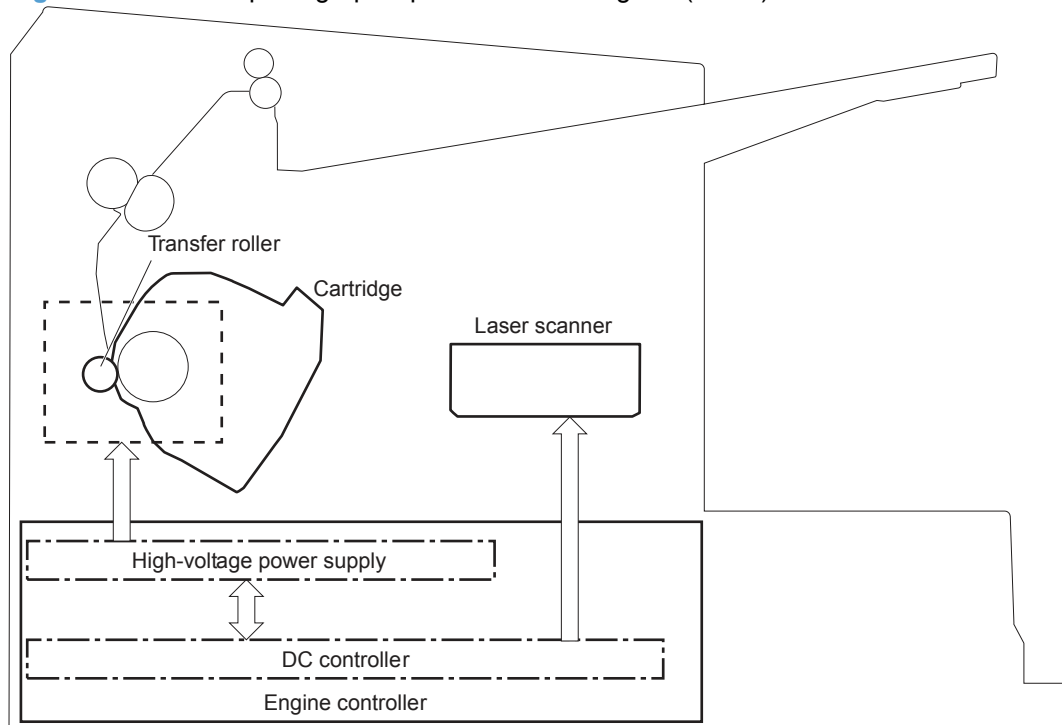

The DC controller rotates the main motor to drive the following components:

- Photosensitive drum
- Developing drum
- Primary charging roller (follows the rotation of the photosensitive drum)
- Transfer roller (follows the rotation of the photosensitive drum)

Figure 1-14 Electrophotographic process block diagram (2 of 2)

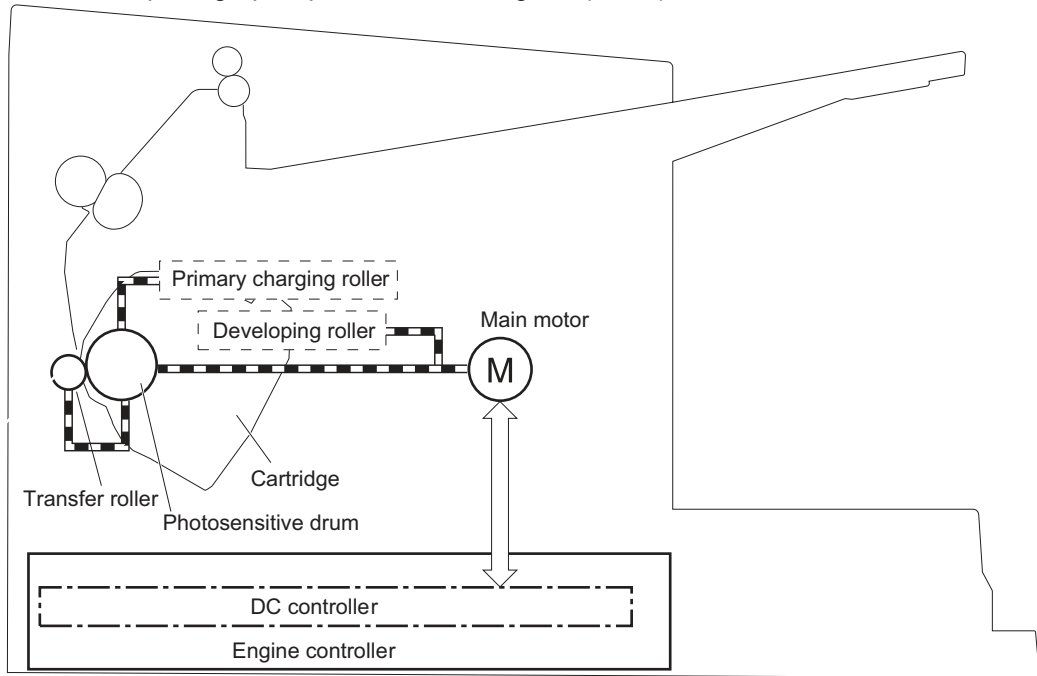
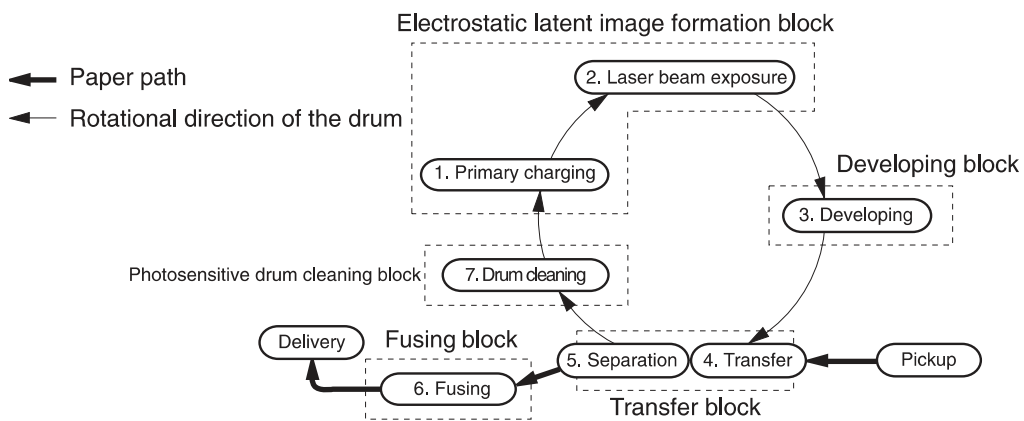

Image formation process

Each of the following process function independently and must be coordinated with the other product processes. Image formation consists of the following processes:

- Latent-image formation block
 - Step 1: primary charging
 - Step 2: laser-beam exposure
- Developing block
 - Step 3: developing
- Transfer block
 - Step 4: transfer
 - Step 5: separation
- Fusing block
 - Step 6: fusing
- Drum cleaning block
 - Step 7: drum cleaning

Figure 1-15 Image formation process



Latent-image formation stage

During the latent-image formation stage, the laser/scanner forms an invisible image on the photosensitive drum in the print cartridge.

Primary charging

Step 1: dc and ac biases are applied to the primary charging roller, which transfers a uniform negative potential to the photosensitive drum.

Figure 1-16 Primary charging

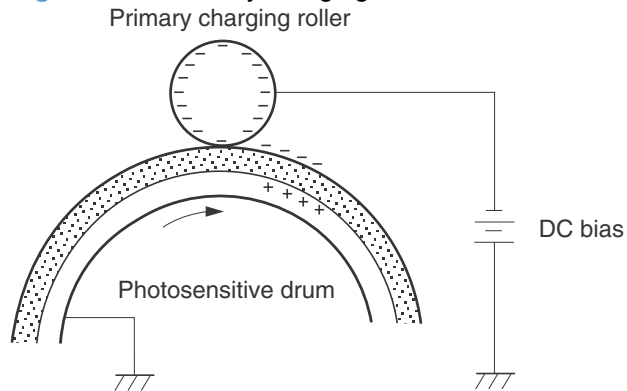

Laser beam exposure

Step 2: The laser beam scans the photosensitive drum to neutralize negative charges on parts of the drum surface. An electrostatic latent image is formed on the drum where negative charges were neutralized.

Figure 1-17 Laser beam exposure

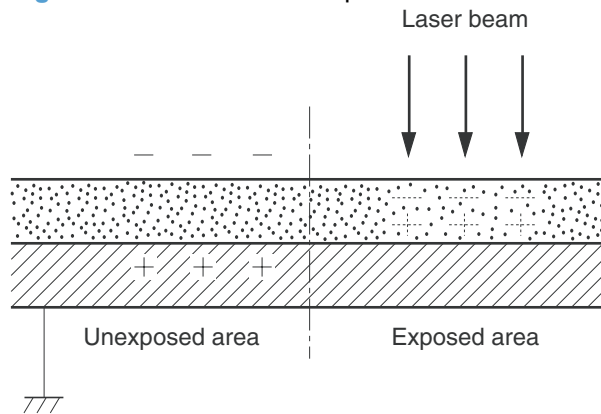

Developing stage

Print cartridge

Step 3: In the print cartridge, the developing cylinder transfers toner onto the electrostatic latent image on the photosensitive drum.

Figure 1-18 Print cartridge

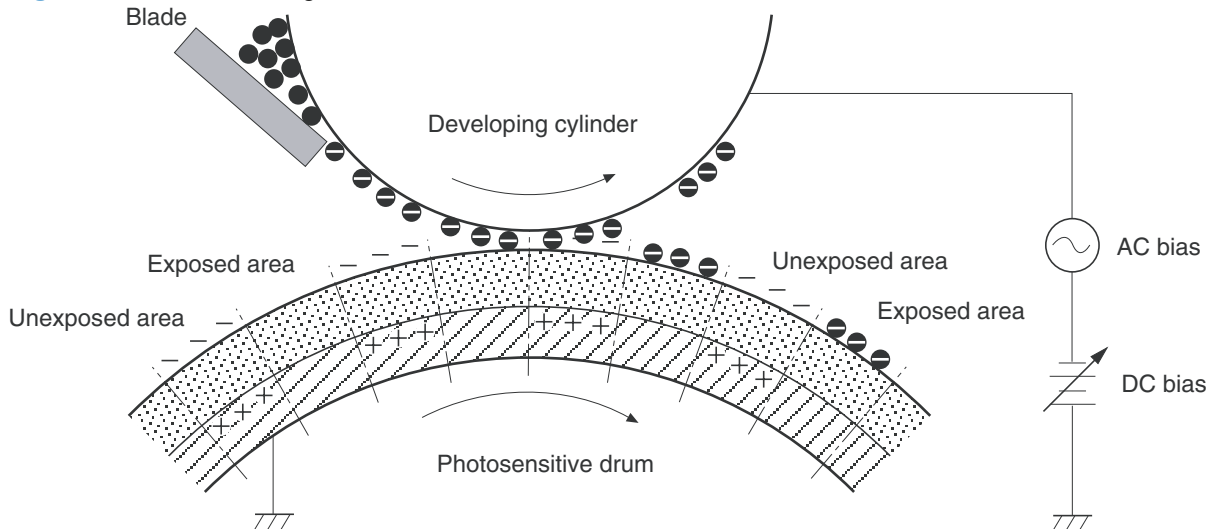

Toner acquires a negative charge from the friction that occurs when the developing roller rotates against the developing blade. The developing bias is applied to the developing roller to make a potential difference between the developing roller and the photosensitive drum. The negatively charged toner is attracted to the latent image on the photosensitive drum because the drum surface has a higher potential.

Transfer stage

Step 4: The transfer charging roller, to which a DC positive bias is applied, imparts a positive charge on the paper. When the paper comes in contact with the photosensitive drum, the toner is transferred to the paper.

Figure 1-19 Transfer

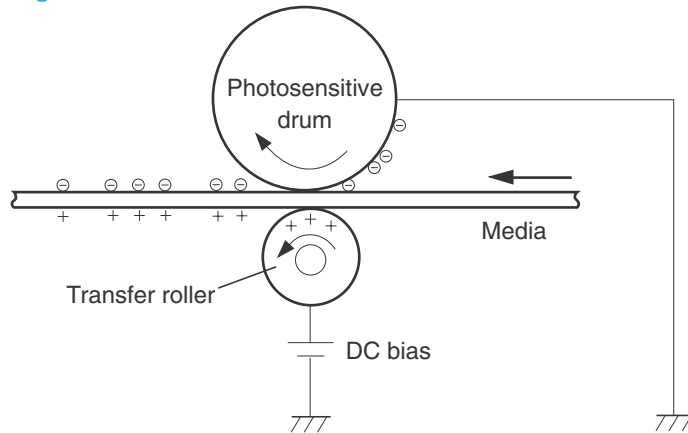

Step 5: The elasticity of the paper causes its separation from the photosensitive drum. A static charge eliminator aids separation by weakening any electrostatic adhesion.

Figure 1-20 Separation

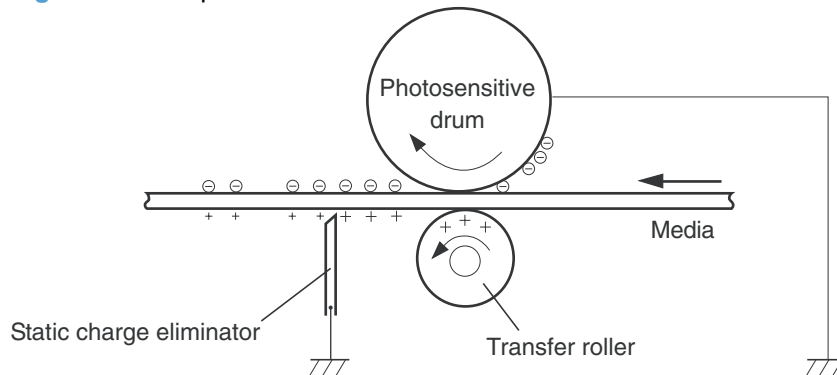

Fusing stage

Step 6: The DC negative bias applied to the fusing film strengthens the holding force of the toner on the paper and prevents the toner from scattering.

The product uses an on-demand fuser method. The toner image is permanently affixed to the paper by heat and pressure.

Figure 1-21 Fusing

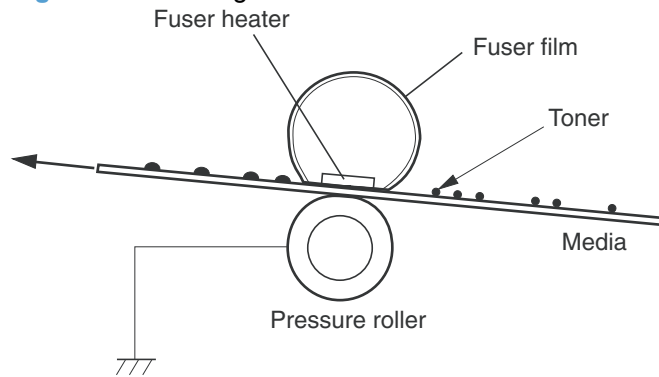

Cleaning stage

Step 7: The cleaning blade scrapes the residual toner off of the photosensitive drum and deposits it into the waste toner case.

Figure 1-22 Drum cleaning

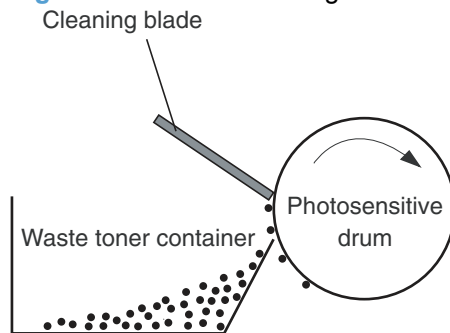

Pickup, feed, and delivery system

The media feed system picks up, feeds, and delivers the page.

Figure 1-23 Pickup, feed, and delivery system block diagram

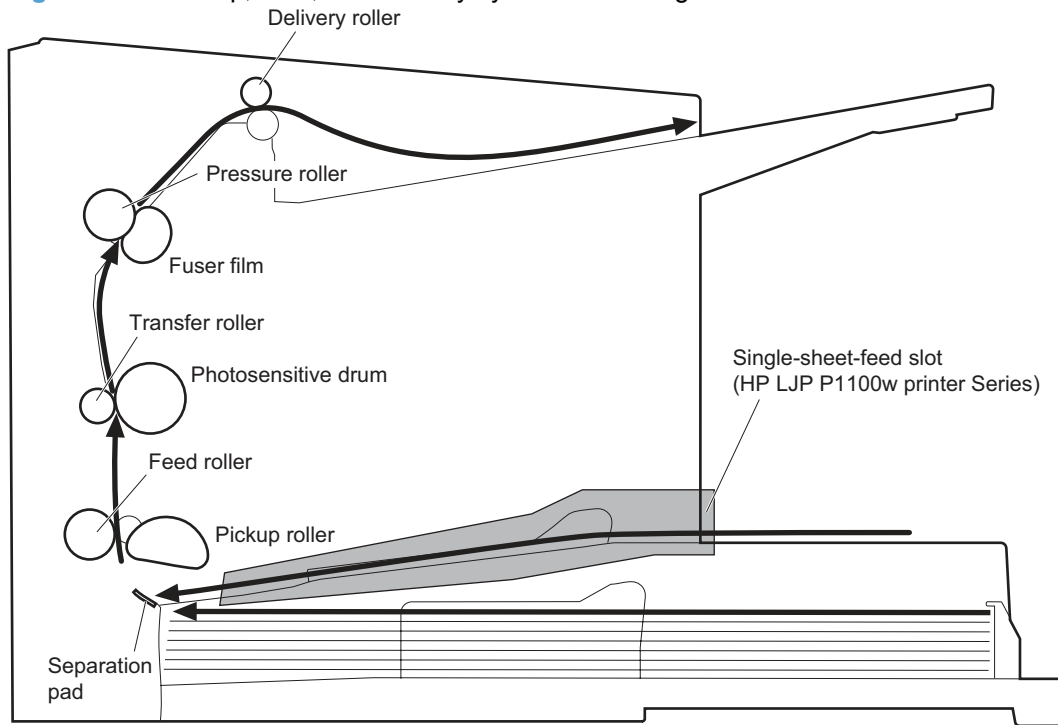

Photo sensors and switches

 **NOTE:** The illustration in this section also shows the product motor and solenoid. The power switch is not shown.

Figure 1-24 Photo sensors, motor, and solenoid

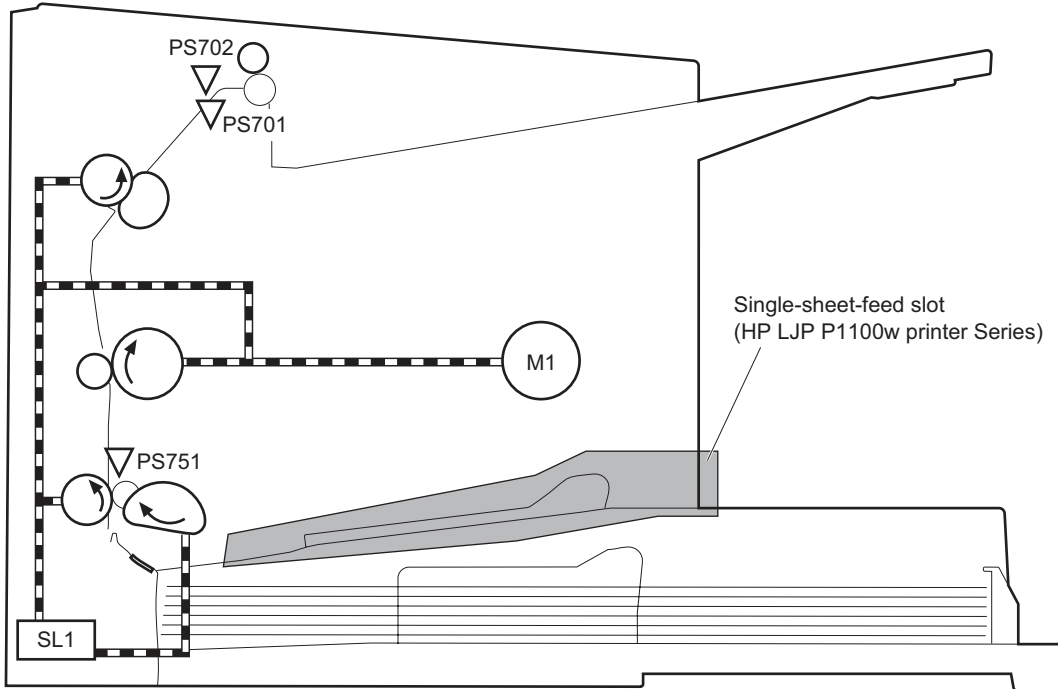



Table 1-7 Photo sensors, motor, and solenoid

Item	Description
M1	Main motor
SL1	Pickup solenoid
PS701	Fuser delivery sensor
PS702	Media-width sensor
PS751	TOP sensor

Input tray, main-input tray, or priority input slot

 **NOTE:** The HP LaserJet Professional P1100 Printer series has a single input tray. The HP LaserJet Professional P1100w Printer series has a main-input tray and a priority input slot.

Jam detection

The product uses the following sensors to detect the presence of paper and to check for jams. The paper must pass each sensor within a specified time.

 **NOTE:** To find the following components, see [Photo sensors and switches on page 29](#).

- PS701; fuser delivery sensor
- PS702; TOP sensor

 **NOTE:** The product automatically ejects paper if the TOP sensor detects residual paper within the product when the power is turned on or the door is closed.

The product detects the following jams:

- Pickup stationary jam
- Delivery delay jam
- Delivery stationary jam
- Fuser wrapping jam
- Door open jam
- Residual media jam

2 Removal and replacement

- [Introduction](#)
- [Removal and replacement strategy](#)
- [Electrostatic discharge](#)
- [Required tools](#)
- [Before performing service](#)
- [After performing service](#)
- [Post-service test](#)
- [Parts removal order](#)
- [Pickup roller](#)
- [Separation pad](#)
- [Transfer roller](#)
- [Covers](#)
- [Main assemblies](#)

Introduction

This chapter describes the removal and replacement of field-replaceable units (FRUs) only.

Replacing FRUs is generally the reverse of removal. Occasionally, notes and tips are included to provide directions for difficult or critical replacement procedures.

HP does *not* support repairing individual subassemblies or troubleshooting to the component level.

Note the length, diameter, color, type, and location of each screw. Be sure to return each screw to its original location during reassembly.

Incorrectly routed or loose wire harnesses can interfere with other internal components and can become damaged or broken. Frayed or pinched harness wires can be difficult to find. When replacing wire harnesses, always use the provided wire loops, lance points, or wire-harness guides and retainers.



Removal and replacement strategy

- ! **WARNING!** Turn the product off, wait 5 seconds, and then remove the power cord before attempting to service the product. If this warning is not followed, severe injury can result, in addition to damage to the product. The power must be on for certain functional checks during troubleshooting. However, disconnect the power supply during parts removal.

Never operate or service the product with the protective cover removed from the laser/scanner assembly. The reflected beam, although invisible, can damage your eyes.

The sheet-metal parts can have sharp edges. Be careful when handling sheet-metal parts.

CAUTION: Do not bend or fold the flat flexible cables (FFCs) during removal or installation. Also, do not straighten pre-folds in the FFCs. You *must* fully seat all FFCs in their connectors. Failure to fully seat an FFC into a connector can cause a short circuit in a PCA.

-  **NOTE:** To install a self-tapping screw, first turn it counterclockwise to align it with the existing thread pattern, and then carefully turn it clockwise to tighten. Do not overtighten. If a self-tapping screw-hole becomes stripped, repair the screw-hole or replace the affected assembly.
-  **TIP:** For clarity, some photos in this chapter show components removed that would not be removed to service the product. If necessary, remove the components listed at the beginning of a procedure before proceeding to service the product.

Electrostatic discharge

CAUTION:  Some parts are sensitive to electrostatic discharge (ESD). Look for the ESD reminder when removing product parts. Always perform service work at an ESD-protected workstation or mat, or use an ESD strap. If an ESD workstation, mat, or strap is not available, ground yourself by touching the sheet-metal chassis *before* touching an ESD-sensitive part.

Protect the ESD-sensitive parts by placing them in ESD pouches when they are out of the product.

Required tools

- #2 Phillips screwdriver with a magnetic tip and a 152-mm (6-inch) shaft length
- Small flat-blade screwdriver
- Needle-nose pliers
- ESD mat or ESD strap (if one is available)
- Penlight (optional)

CAUTION: Always use a Phillips screwdriver (callout 1). Do not use a pozidrive screwdriver (callout 2) or any motorized screwdriver. These can damage screws or screw threads.

Figure 2-1 Phillips and pozidrive screwdriver comparison

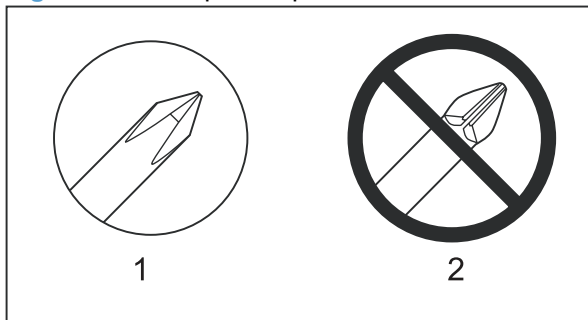

Before performing service

- Remove all paper from the product.
- Turn off the power using the power switch.
- Unplug the power cable and interface cable or cables.
- Place the product on an ESD workstation or mat, or use an ESD strap (if one is available). If an ESD workstation, mat, or strap is not available, ground yourself by touching the sheet-metal chassis *before* touching an ESD-sensitive part.
- Remove the print cartridge.

After performing service

- Plug in the power cable.
- Reinstall the print cartridge.
- Load paper in the product.

Post-service test

Perform the following test to verify that the repair or replacement was successful.

Print-quality test

1. Verify that you have completed the necessary reassembly steps.
2. Make sure that the tray contains clean, unmarked paper.
3. Attach the power cord and interface cable or interface cables, and then turn on the product.
4. Verify that the expected startup sounds occur.
5. Print a configuration page, and then verify that the expected printing sounds occur.
6. Print a demo page, and then verify that the print quality is as expected.
7. Send a print job from the host computer, and then verify that the output meets expectations.
8. Clean the outside of the product with a damp cloth.

Parts removal order

Figure 2-2 Parts removal order

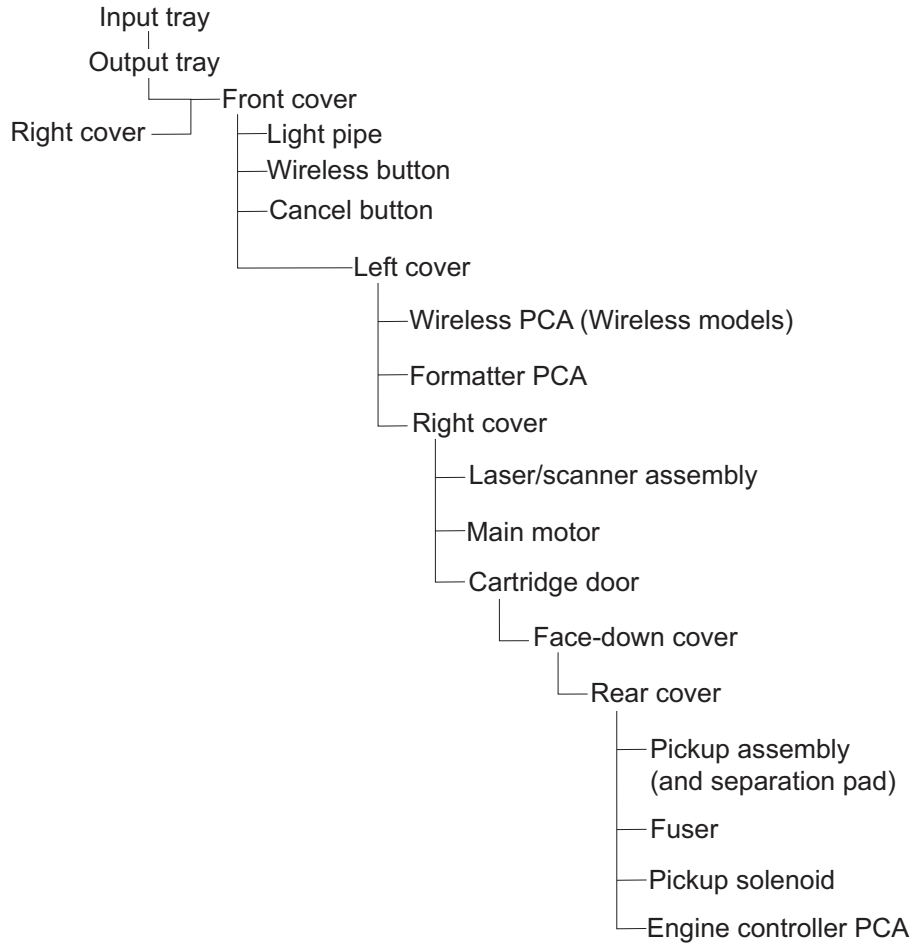

Pickup roller

CAUTION: Do not touch the sponge portion of the roller. Skin oils can cause paper handling problems.

1. Release two tabs.

Figure 2-3 Remove the pickup roller (1 of 2)

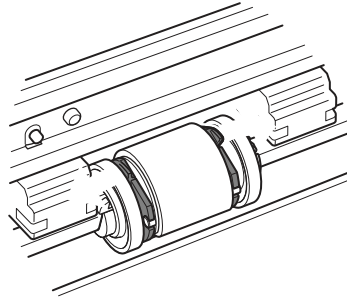

2. Rotate the roller away from the product to remove it.

Figure 2-4 Remove the pickup roller (2 of 2)

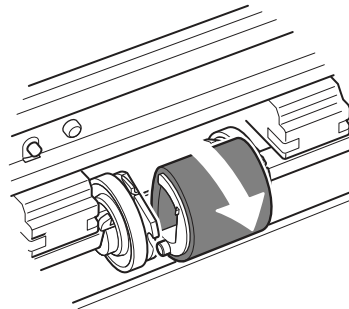

Separation pad

CAUTION: Do not touch the sponge portion of the pad. Skin oils can cause paper handling problems.

1. Place the product rear-side up to access the separation pad assembly.

CAUTION: Dirt and debris can scratch the product covers. Place the product on a cloth or other clean surface.

2. Remove two screws (callout 1) and then remove the separation pad assembly (callout 2).

Figure 2-5 Remove the separation pad assembly

Transfer roller

CAUTION: Do not touch the sponge portion of the roller. Skin oils can cause print quality problems.

1. Open the print-cartridge door.
2. Release two tabs (callout 1), and then remove the transfer roller (callout 2).

Figure 2-6 Remove the transfer roller

Covers

Input tray or main-input tray

Open the tray (callout 1), release two tabs (callout 2), and then remove the tray.

Figure 2-7 Remove the tray

Output bin tray extension

Release two pins (callout 1), and then remove the tray extension (callout 2)

Figure 2-8 Remove the output bin tray extension

Front cover

Before proceeding, remove the following components:

- Input tray or main-input tray. See [Input tray or main-input tray on page 40](#).
- Output bin tray extension. See [Output bin tray extension on page 41](#).

Remove the front cover

1. Place the product rear-side up.

△ CAUTION: Dirt and debris can scratch the product covers. Place the product on a cloth or other clean surface.

2. Release two tabs (callout 1), and then remove the front cover (callout 2).

Figure 2-9 Remove the front cover

Left cover

 **NOTE:** For the HP LaserJet Professional P1100w Printer series, removing the left cover also removes the control panel.

Before proceeding, remove the following components:

- Input tray or main-input tray. See [Input tray or main-input tray on page 40](#).
- Output bin tray extension. See [Output bin tray extension on page 41](#).
- Front cover. See [Front cover on page 42](#).

Remove the left cover

1. Use the figure below to locate the tabs (callout 1) on the cover.

Figure 2-10 Remove the left cover (1 of 5)

2. Open the cartridge door, release one tab (callout 1) and then remove the left plate (callout 2).

Figure 2-11 Remove the left cover (2 of 5)

3. **HP LaserJet Professional P1100 Printer series:** Remove the light pipe (callout 1).

HP LaserJet Professional P1100w Printer series: Remove the light pipe (callout 1), wireless button (callout 2), and the cancel button (callout 3).

Figure 2-12 Remove the left cover (3 of 5)

4. Remove one screw (callout 1).

Figure 2-13 Remove the left cover (4 of 5)

5. Release three tabs (callout 1) at the top, rear, and bottom of the cover, slide the cover toward the front of the product to release two tabs (callout 2), and then remove the left cover (callout 3).

Figure 2-14 Remove the left cover (5 of 5)

Right cover

Before proceeding, remove the following components:

- Input tray or main-input tray. See [Input tray or main-input tray on page 40](#).
- Output bin tray extension. See [Output bin tray extension on page 41](#).
- Front cover. See [Front cover on page 42](#).

Remove the right cover

1. Use the figure below to locate the tabs (callout 1) on the cover.

Figure 2-15 Remove the right cover (1 of 3)

2. Remove on screw (callout 1), and open the print-cartridge door.

Figure 2-16 Remove the right cover (2 of 3)

3. Release three tabs (callout 1) at the top, rear, and bottom of the cover, slide the cover toward the front of the product to release two tabs (callout 2), and then remove the left cover (callout 3).

Figure 2-17 Remove the right cover (3 of 3)

Cartridge door

Before proceeding, remove the following components:

- Input tray or main-input tray. See [Input tray or main-input tray on page 40](#).
- Output bin tray extension. See [Output bin tray extension on page 41](#).
- Front cover. See [Front cover on page 42](#).
- Left cover. See [Left cover on page 43](#).
- Right cover. See [Right cover on page 46](#).

Remove the cartridge door

1. Open the cartridge door, and then release the tabs on the link arms (callout 1).

Figure 2-18 Remove the cartridge door (1 of 2)

2. Release two pins (callout 1), and then remove the cartridge door (callout 2).

Figure 2-19 Remove the cartridge door (2 of 2)

Face-down cover

Before proceeding, remove the following components:

- Input tray or main-input tray. See [Input tray or main-input tray on page 40](#).
- Output bin tray extension. See [Output bin tray extension on page 41](#).
- Front cover. See [Front cover on page 42](#).
- Left cover. See [Left cover on page 43](#).
- Right cover. See [Right cover on page 46](#).
- Cartridge door assembly. See [Cartridge door on page 48](#)

Remove the face-down cover

1. Release two tabs (callout 1), and slightly separate the face-down cover from the rear cover.

Figure 2-20 Remove the face-down cover (1 of 2)



2. Rotate the bottom of the cover away from the product and then remove the cover.

 **Reinstallation tip** When you reinstall the cover, make sure that the tabs on the cover fit into the slots in the top of the chassis near the print-cartridge opening.

It might be easier to reinstall the cover if you remove the rear cover first. See [Rear cover on page 52](#).

Figure 2-21 Remove the face-down cover (2 of 2)



Rear cover

Before proceeding, remove the following components:

- Input tray or main-input tray. See [Input tray or main-input tray on page 40](#).
- Output bin tray extension. See [Output bin tray extension on page 41](#).
- Front cover. See [Front cover on page 42](#).
- Left cover. See [Left cover on page 43](#).
- Right cover. See [Right cover on page 46](#).
- Face-down cover. See [Face-down cover on page 50](#).

Remove the rear cover

1. Remove one screw with washer (callout 1).

Figure 2-22 Remove the rear cover (1 of 2)

2. Release the bottom two corners of the cover, and then rotate the bottom of the cover away from the product to remove it.

Figure 2-23 Remove the rear cover (2 of 2)



Main assemblies

 **NOTE:** Some photos in this section show components that might not be installed or removed from your product; however, the procedures for replacement and repair in this chapter are correct for your product.

Formatter PCA

Before proceeding, remove the following components:

- Input tray or main-input tray. See [Input tray or main-input tray on page 40](#).
- Output bin tray extension. See [Output bin tray extension on page 41](#).
- Front cover. See [Front cover on page 42](#).
- Left cover. See [Left cover on page 43](#).

Remove the formatter PCA

1. HP LaserJet Professional P1100 Printer series: Disconnect one FFC (callout 1).
HP LaserJet Professional P1100w Printer series: Disconnect two FFCs (callout 1).

Figure 2-24 Remove the formatter PCA (HP LaserJet Professional P1100 Printer series; 1 of 4)

Figure 2-25 Remove the formatter PCA (HP LaserJet Professional P1100w Printer series; 2 of 4)

2. HP LaserJet Professional P1100 Printer series: Remove three screws (callout 1), and then remove the PCA (callout 2).

HP LaserJet Professional P1100w Printer series: Remove three screws (callout 1), release one tab (callout 2), and then remove the PCA (callout 3).

Figure 2-26 Remove the formatter PCA (HP LaserJet Professional P1100 Printer series; 3 of 4)

Figure 2-27 Remove the formatter PCA (HP LaserJet Professional P1100w Printer series; 4 of 4)

Wireless PCA

 **NOTE:** HP LaserJet Professional P1100w Printer series only.

Before proceeding, remove the following components:

- Input tray or main-input tray. See [Input tray or main-input tray on page 40](#).
- Output bin tray extension. See [Output bin tray extension on page 41](#).
- Front cover. See [Front cover on page 42](#).
- Left cover. See [Left cover on page 43](#).

Remove the wireless PCA

Disconnect one FFC (callout 1), release one tab (callout 2), and then remove the PCA (callout 3).

Figure 2-28 Remove the wireless PCA

Laser/scanner assembly

Before proceeding, remove the following components:

- Input tray or main-input tray. See [Input tray or main-input tray on page 40](#).
- Output bin tray extension. See [Output bin tray extension on page 41](#).
- Front cover. See [Front cover on page 42](#).
- Left cover. See [Left cover on page 43](#).
- Right cover. See [Right cover on page 46](#).

Remove the laser/scanner assembly

1. Release one tab (callout 1), and then remove the holder (callout 2).

Figure 2-29 Remove the laser/scanner assembly (1 of 4)

2. Remove four screws (callout 1), the scanner cover (callout 2) and the sheet-metal plate (callout 3).

 **NOTE:** The scanner cover and plate are removed as one assembly.

 **TIP:** When the cover is reinstalled, make sure that the black screws (callout 4) are installed in the correct screw holes.

Figure 2-30 Remove the laser/scanner assembly (2 of 4)

3. Disconnect one FFC (callout 1), and then remove four screws (callout 2).

Figure 2-31 Remove the laser/scanner assembly (3 of 4)

4. Disconnect one connector (callout 1), and then remove the laser/scanner assembly (callout 2).

Figure 2-32 Remove the laser/scanner assembly (4 of 4)

Reinstall the laser/scanner assembly

- ▲ When the holder is reinstalled (callout 1), make sure that the lever arm (callout 2) is correctly positioned.

Figure 2-33 Reinstall the laser/scanner assembly

Pickup assembly

Before proceeding, remove the following components:

- Separation pad. See [Separation pad on page 38](#).
- Input tray or main-input tray. See [Input tray or main-input tray on page 40](#).
- Output bin tray extension. See [Output bin tray extension on page 41](#).
- Front cover. See [Front cover on page 42](#).
- Left cover. See [Left cover on page 43](#).
- Right cover. See [Right cover on page 46](#).
- Cartridge door assembly. See [Cartridge door on page 48](#).
- Face-down cover. See [Face-down cover on page 50](#).
- Rear cover. See [Rear cover on page 52](#).
- Formatter PCA. See [Formatter PCA on page 54](#).
- Wireless PCA. See [Wireless PCA on page 57](#).

Remove the pickup assembly

1. Remove three screws (callout 1), and then remove the plastic plate (callout 2).

Figure 2-34 Remove the pickup assembly (1 of 7)

2. Remove one screw (callout 1), and then remove the sheet-metal plate (callout 2).

Figure 2-35 Remove the pickup assembly (2 of 7)

3. Disconnect one connector (callout 1), and then remove the wire harness (callout 2) from the guide (callout 3).

Figure 2-36 Remove the pickup assembly (3 of 7)

4. Disconnect three connectors (callout 1), and then remove the wire harness (callout 2) from the guide (callout 3).

Figure 2-37 Remove the pickup assembly (4 of 7)

5. Remove one bushing (callout 1).

Figure 2-38 Remove the pickup assembly (5 of 7)

6. Remove one screw with washer (callout 1).

Figure 2-39 Remove the pickup assembly (6 of 7)

7. Remove six screws (callout 1), and then remove the pickup assembly (callout 2).

Figure 2-40 Remove the pickup assembly (7 of 7)

Reinstall the pickup assembly

1. Make sure that the pickup assembly ground spring is correctly positioned when the assembly is reinstalled.

Figure 2-41 Reinstall the pickup assembly (1 of 4; correct ground spring position)

Figure 2-42 Reinstall the pickup assembly (2 of 4; incorrect ground spring position)

2. Push down the lift plate before installing the pickup assembly.

☞ **TIP:** Reach in from the front of the product to push and hold the plate down as the pickup unit is installed.

Figure 2-43 Reinstall the pickup assembly (3 of 4; lift plate in raised position)

Figure 2-44 Reinstall the pickup assembly (4 of 4; lift plate in lowered position)

Fuser

Before proceeding, remove the following components:

- Input tray or main-input tray. See [Input tray or main-input tray on page 40](#).
- Output bin tray extension. See [Output bin tray extension on page 41](#).
- Front cover. See [Front cover on page 42](#).
- Left cover. See [Left cover on page 43](#).
- Right cover. See [Right cover on page 46](#).
- Cartridge door assembly. See [Cartridge door on page 48](#)
- Face-down cover. See [Face-down cover on page 50](#).
- Rear cover. See [Rear cover on page 52](#).
- Formatter PCA. See [Formatter PCA on page 54](#).
- Wireless PCA. See [Wireless PCA on page 57](#).

Remove the fuser

1. Remove three screws (callout 1), and then remove the plastic plate (callout 2).

Figure 2-45 Remove the fuser (1 of 7)

2. Remove one screw (callout 1), and then remove the sheet-metal plate (callout 2).

Figure 2-46 Remove the fuser (2 of 7)

3. Disconnect one connector (callout 1), and then remove the wire harness (callout 2) from the guide (callout 3).

Figure 2-47 Remove the fuser (3 of 7)

4. Disconnect four connectors (callout 1), and then release the wire harnesses (callout 2) from the guide (callout 3).

Figure 2-48 Remove the fuser (4 of 7)

5. Disconnect one tab (callout 1), and then remove the guide (callout 2).

Figure 2-49 Remove the fuser (5 of 7)

6. Release the wire harnesses (callout 1) from the guide (callout 2).

Figure 2-50 Remove the fuser (6 of 7)

7. Remove three screws (callout 1) and then remove the fuser (callout 2).

Figure 2-51 Remove the fuser (7 of 7)

Reinstall the fuser

- ▲ To avoid damage to the wire harnesses, make sure that they are correctly installed in the guides when the fuser is reinstalled.

Figure 2-52 Reinstall the fuser; correct wire harness installation

Figure 2-53 Reinstall the fuser; incorrect wire harness installation

Main motor

Before proceeding, remove the following components:

- Input tray or main-input tray. See [Input tray or main-input tray on page 40](#).
- Output bin tray extension. See [Output bin tray extension on page 41](#).
- Front cover. See [Front cover on page 42](#).
- Left cover. See [Left cover on page 43](#).
- Right cover. See [Right cover on page 46](#).

Remove the main motor

1. Release one tab (callout 1), and then remove the holder (callout 2).

Figure 2-54 Remove the main motor (1 of 7)

2. Remove four screws (callout 1), the scanner cover (callout 2) and the sheet-metal plate (callout 3).

 **NOTE:** The scanner cover and plate are removed as one assembly.

 **TIP:** When the cover is reinstalled, make sure that the black screws (callout 4) are installed in the correct screw holes.

Figure 2-55 Remove the main motor (2 of 7)

3. Release two tabs (callout 1), and then slightly separate the motor driver PCA (callout 2) from the product.

CAUTION: The motor driver PCA is still connected to the product by the wire harnesses and a FFC.

Figure 2-56 Remove the main motor (3 of 7)

4. Disconnect two connectors (callout 1) and carefully set the PCA out of the way.

CAUTION: The motor driver PCA is still connected to the product by the FFC.

Figure 2-57 Remove the main motor (4 of 7)

5. Release the wire harness (callout 1) from the guide (callout 2).

Figure 2-58 Remove the main motor (5 of 7)

6. Remove one screw (callout 1), and then remove the motor cover (callout 2).

Figure 2-59 Remove the main motor (6 of 7)

7. Remove two screws (callout 1), and then remove the motor (callout 2).

Figure 2-60 Remove the main motor (7 of 7)

Reinstall the main-motor drive belt

- ▲ When the main motor is reinstalled, make sure that the drive belt (callout 1) is correctly positioned over the roller (callout 2).

Figure 2-61 Main-motor drive belt: correctly installed

Figure 2-62 Main-motor drive belt: incorrectly installed

Pickup solenoid

Before proceeding, remove the following components:

- Input tray or main-input tray. See [Input tray or main-input tray on page 40](#).
- Output bin tray extension. See [Output bin tray extension on page 41](#).
- Front cover. See [Front cover on page 42](#).
- Left cover. See [Left cover on page 43](#).
- Right cover. See [Right cover on page 46](#).
- Cartridge door assembly. See [Cartridge door on page 48](#)
- Face-down cover. See [Face-down cover on page 50](#).
- Rear cover. See [Rear cover on page 52](#).
- Formatter PCA. See [Formatter PCA on page 54](#).
- Wireless PCA. See [Wireless PCA on page 57](#).

Remove the pickup solenoid

1. Remove three screws (callout 1), and then remove the plastic plate (callout 2).

Figure 2-63 Remove the pickup solenoid (1 of 5)

2. Remove one screw (callout 1), and then remove the sheet-metal plate (callout 2).

Figure 2-64 Remove the pickup solenoid (2 of 5)

3. Disconnect one connector (callout 1), and then release the wire harness (callout 2) from the guide (callout 3).

Figure 2-65 Remove the pickup solenoid (3 of 5)

4. Release the wire harness (callout 1) from the guide (callout 2).

Figure 2-66 Remove the pickup solenoid (4 of 5)

5. Remove one screw (callout 1), and then remove the pickup solenoid (callout 2).

Figure 2-67 Remove the pickup solenoid (5 of 5)

Engine controller PCA

 **NOTE:** Some photos in this section show a product similar to the HP LaserJet Professional P1100 Printer series or the HP LaserJet Professional P1100w Printer series, however the procedures for replacement and repair in this section are correct for your product.

Before proceeding, remove the following components:

- Input tray or main-input tray. See [Input tray or main-input tray on page 40](#).
- Output bin tray extension. See [Output bin tray extension on page 41](#).
- Front cover. See [Front cover on page 42](#).
- Left cover. See [Left cover on page 43](#).
- Right cover. See [Right cover on page 46](#).
- Cartridge door assembly. See [Cartridge door on page 48](#)
- Face-down cover. See [Face-down cover on page 50](#).
- Rear cover. See [Rear cover on page 52](#).
- Formatter PCA. See [Formatter PCA on page 54](#).
- Wireless PCA. See [Wireless PCA on page 57](#).

Remove the engine controller PCA

1. Remove three screws (callout 1), and then remove the plastic plate (callout 2).

Figure 2-68 Remove the engine controller PCA (1 of 8)

2. Remove one screw (callout 1), and then remove the sheet-metal plate (callout 2).

Figure 2-69 Remove the engine controller PCA (2 of 8)

3. Disconnect one connector (callout 1), and then release the wire harness (callout 2) from the guides (callout 3).

Figure 2-70 Remove the engine controller PCA (3 of 8)

4. Disconnect four connectors (callout 1), and then remove the wire harnesses (callout 2) from the guide (callout 3).

Figure 2-71 Remove the engine controller PCA (4 of 8)

5. Release the wire harness (callout 1) from the ground spring (callout 2).

Figure 2-72 Remove the engine controller PCA (5 of 8)

6. Disconnect two connectors (callout 1) and two FFCs (callout 2).

Figure 2-73 Remove the engine controller PCA (6 of 8)

7. Remove one screw with washer (callout 1), and then remove one more screw (callout 2).

Figure 2-74 Remove the engine controller PCA (7 of 8)

8. Remove three screws with washers (callout 1), and then remove the engine controller PCA (callout 2).

Figure 2-75 Remove the engine controller PCA (8 of 8)

Reinstall the engine controller PCA

 **NOTE:** Follow these steps to correctly install the transfer-wire harness.

1. Set the ground spring (callout 1) on the transfer-wire harness (callout 2).

Figure 2-76 Reinstall the engine controller PCA (1 of 4)

2. Position the transfer-wire harness (callout 1) in the guide (callout 2).

Figure 2-77 Reinstall the engine controller PCA (2 of 4)

3. Connect one connector (callout 1).

Figure 2-78 Reinstall the engine controller PCA (3 of 4)

4. Position the transfer-wire harness (callout 1) in the guides (callout 2).

Figure 2-79 Reinstall the engine controller PCA (4 of 4)

3 Solve problems

- [Solve problems checklist](#)
- [Troubleshooting process](#)
- [Tools for troubleshooting](#)
- [Clear jams](#)
- [Solve paper-handling problems](#)
- [Solve image-quality problems](#)
- [Clean the product](#)
- [Solve performance problems](#)
- [Solve connectivity problems](#)
- [Service mode functions](#)
- [Product updates](#)

Solve problems checklist

Table 3-1 Basic problem solving

Problem	Cause	Solution
When the product is connected to a correctly grounded power source, the LEDs on the control panel do not illuminate and the main motor does not rotate. The product does not turn on.	No power to the product.	<ol style="list-style-type: none"> 1. Verify that the power switch is turned on. 2. Verify that the power cable is correctly plugged into the outlet and the product. 3. Verify that the power outlet has the correct voltage.
	The formatter is defective.	Replace the formatter. See Formatter PCA on page 54 .
	The engine controller PCA is defective.	Replace the engine controller PCA. See Engine controller PCA on page 80 .
When turned on, the LEDs on the control panel light up, but the main motor does not rotate. The product turns on, but the motor does not rotate.	The print-cartridge door is open.	Close the print-cartridge door.
	A page is jammed in the paper path.	Clear all pages from the paper path, and make sure that all sensors are working correctly.
	The cable is not connected correctly.	Reconnect the motor cable.
	The motor is not mounted correctly in the product chassis.	Verify that the motor is connected correctly and that it rotates freely.
	The engine controller PCA is defective.	Replace the engine controller PCA. See Engine controller PCA on page 80 .
	The main motor is defective.	Replace the motor. See Main motor on page 72 .
The product turns on and the motor rotates, but none of the control-panel lights turn on. For the HP LaserJet Professional P1100w Printer series, the control-panel buttons are unresponsive. The product is unresponsive.	The formatter is defective. For the HP LaserJet Professional P1100w Printer series, the wireless PCA is defective.	Replace the formatter. See Formatter PCA on page 54 . For the HP LaserJet Professional P1100w Printer series, replace the wireless PCA. See Wireless PCA on page 57
The product is on, but the control-panel lights indicate that the product is not in the "ready" state. The product is not "ready."	The product has an internal error that was detected during the Power-On Self-Test sequence.	Consult the list of control-panel light patterns to identify and correct the error.

Table 3-1 Basic problem solving (continued)

Problem	Cause	Solution
The product turns on, the motor rotates, and the control panel indicates the "ready" state, but the product does not print. The product does not print.	A component is defective.	Perform an engine test to verify print-engine components. <ol style="list-style-type: none">1. Print an engine test page. See Engine-test button on page 93.2. If the engine test page does not print, check all the connectors on the engine controller PCA, and reconnect any cables that are connected incorrectly.3. If, after checking the connectors, the error persists, replace the engine controller PCA. See Engine controller PCA on page 80.
	The formatter is defective.	Print a demo page. Select Demo Page from the Print Information Pages drop-down on the Services tab in the printer driver. If the Demo page does not print, replace the formatter. See Formatter PCA on page 54 .

Table 3-1 Basic problem solving (continued)

Problem	Cause	Solution
The product prints the engine test or the configuration page (HP LaserJet Professional P1100w Printer series only), but does not print jobs from a computer.	The cable is not connected correctly.	Reconnect the cable. Try using a new USB cable that is 3 m (10 ft) or less in length.
The product does not print from a computer.	For the HP LaserJet Professional P1100w Printer series, the wireless connection has been lost.	See Solve wireless problems on page 130 .
	An incorrect driver is selected.	Select the correct printer driver.
	The printer driver is not installed correctly.	Remove and then reinstall the product software. Make sure that you use the correct procedure and port setting.
	Other devices are connected to the product (for example, through a switch or hub) that are interfering with the computer-product communications.	Disconnect the other devices, switches, or hubs.
	There is a computer-port communications problem.	Reset the computer port settings (see the computer user guide for more information).
	The formatter is defective.	Replace the formatter. See Formatter PCA on page 54 .
	For the HP LaserJet Professional P1100w Printer series, the wireless PCA is defective.	Replace the wireless PCA. See Wireless PCA on page 57 .

Troubleshooting process

Determine the problem source

The following table includes basic questions to ask the customer to quickly help define the problem or problems.

General topic	Questions
Environment	<ul style="list-style-type: none">• Is the product installed on a solid, level surface ($\pm 1^\circ$)?• Is the power-supply voltage within ± 10 volts of the specified power source?• Is the power-supply plug inserted in the product and the outlet?• Is the operating environment within the specified parameters?• Is the product exposed to ammonia gas, such as that produced by diazo copiers or office cleaning materials? NOTE: Diazo copiers produce ammonia gas as part of the copying processes. Ammonia gas (from cleaning supplies or a diazo copier) can have an adverse affect on some product components (for example, the print-cartridge OPC).• Is the product exposed to direct sunlight?
Paper	<ul style="list-style-type: none">• Does the customer use only supported paper?• Is the paper in good condition (no curls, folds, or distortion)?• Is the paper stored correctly and within environmental limits?
Input trays	<ul style="list-style-type: none">• Is the amount of paper in the tray within specifications?• Is the paper correctly placed in the tray?• Are the paper guides aligned with the stack?
Print cartridge	<ul style="list-style-type: none">• Is the print cartridge installed correctly?
Transfer roller and fuser	<ul style="list-style-type: none">• Are the transfer roller and fuser installed correctly?
Print-cartridge door	<ul style="list-style-type: none">• Is the print-cartridge door closed?
Condensation	<ul style="list-style-type: none">• Does condensation occur following a temperature change (particularly in winter following cold storage)? If so, wipe affected parts dry or leave the product on for 10 to 20 minutes.• Was a print cartridge opened soon after being moved from a cold to a warm room? If so, allow the print cartridge to sit at room temperature for 1 to 2 hours.
Miscellaneous	<ul style="list-style-type: none">• Check for and remove any non-HP components (for example, a print cartridge) from the product.• Remove the product from the network and make sure that the failure is with the product before beginning troubleshooting.

Power subsystem

Power-on checks

Turn on the power. If the control-panel LEDs do not illuminate, perform the power-on checks to find the cause of the problem.

1. Verify that the product is plugged into an active electrical outlet that delivers the correct voltage.
2. Verify that the power switch is in the on position.
3. Make sure that the product makes the expected start-up sounds.

 **NOTE:** The overcurrent/overvoltage protection circuit in the low-voltage power supply unit might be functioning. Turn the product off, unplug the power cord, and turn the product on. If the product does not function, the fuse melts, or the power supply is malfunctioning, replace the engine controller unit. See [Engine controller PCA on page 80](#).

Tools for troubleshooting

Individual component diagnostics

Engine diagnostics

Printing test pages helps you determine whether or not the product engine and the formatter are functioning. If the formatter is damaged, it might interfere with the engine test. If the engine-test page does not print, try removing the formatter and then performing the engine test again. If the engine test is then successful, the problem is almost certainly with the formatter.

 **NOTE:** Information pages also can be used to solve product issues. For information about printing information pages, see the product user guide.

Engine-test button

 **NOTE:** The product has a firmware engine-test button that is activated by opening and closing the print-cartridge door in a specific pattern.

1. Make sure that paper is correctly loaded in the tray.
2. Make sure that the output bin tray extension is in the open position.
3. Turn the product on. Wait for the product to reach the ready state.
4. Open, and then close the print-cartridge door five times at an interval of about two seconds to start the engine-test.
5. If the engine test is successful, an engine-test page prints with a series of vertical lines across the page.

Figure 3-1 Sample engine test page

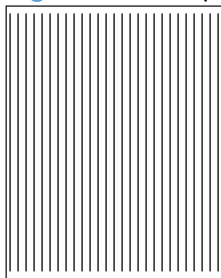

Components tests

Drum rotation functional check

The photosensitive drum, located in the print cartridge, must rotate for the print process to work. The photosensitive drum receives its drive from the main drive assembly.

 **NOTE:** This test is especially important if refilled print cartridges have been used.

1. Open the print-cartridge door.
2. Remove the print cartridge.
3. Mark the drive gear on the cartridge with a felt-tipped marker. Note the position of the mark.
4. Replace the print cartridge and close the print-cartridge door. The startup sequence should rotate the drum enough to move the mark.
5. Open the print-cartridge door and inspect the gear that was marked in step 3. Verify that the mark moved.

If the mark did not move, inspect the main drive assembly to make sure that it is meshing with the print cartridge gears. If the drive gears appear functional and the drum does not move, replace the print cartridge.

Half self-test functional check

The half self-test check determines which printing process is malfunctioning.

1. Print a Configuration page.
2. Open the print-cartridge-door after the paper advances halfway through the product (about five seconds after the motor begins rotating). The leading edge of the paper should have advanced past the print cartridge.
3. Remove the print cartridge.
4. Open the print cartridge drum shield to view the drum surface. If a dark and distinct toner image is present on the drum surface, assume that the first two functions of the electrophotographic process are functioning (image formation and development). Troubleshoot the failure as a transfer or fusing problem.

If there is no image on the photosensitive drum, perform these checks:

1. Make sure you removed the entire length of the sealing tape from the print cartridge before you installed the cartridge.
2. Perform a drum rotation functional check to make sure that the drum is rotating.
3. Make sure that the high-voltage contacts are clean and not damaged.

Diagrams

Plug/jack locations

Figure 3-2 Plug/jack locations



Item	Description
1	USB port
2	Power connector

Location of connectors

Figure 3-3 Engine controller PCA connectors

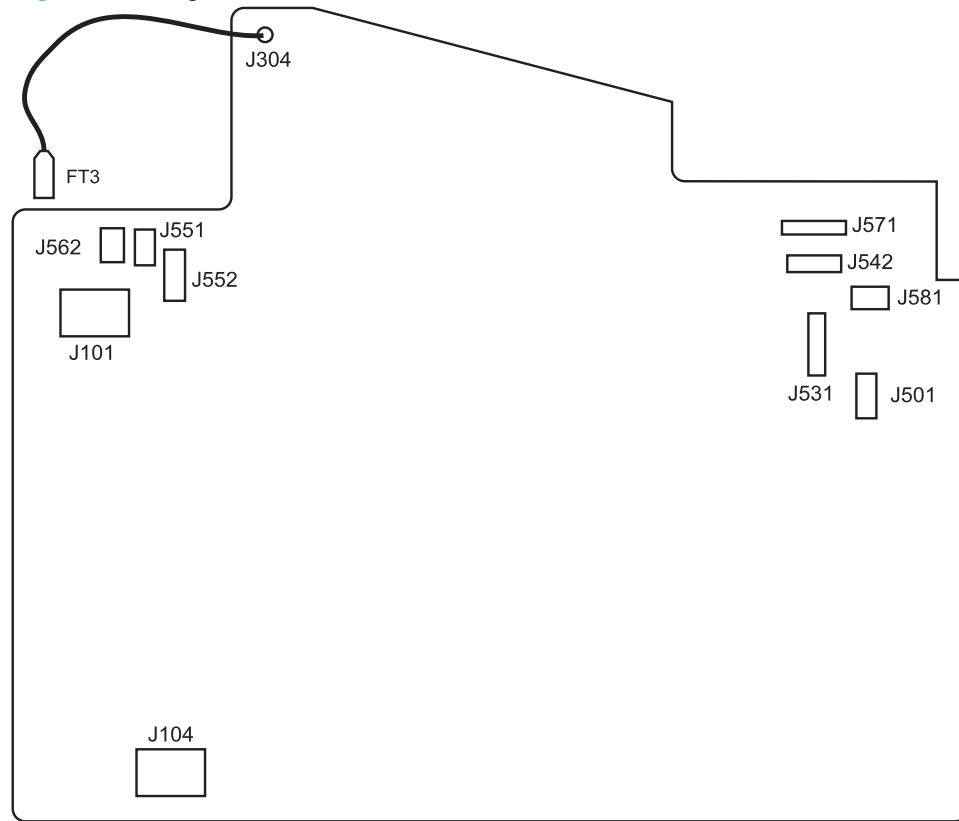

Item	Description	Item	Description
J101	Fuser	J551	Top sensor PCA
J104	Power inlet	J552	Paper-pickup PCA
J304	High voltage	J562	Pickup solenoid
J501	Test point	J571	Motor drive PCA
J531	Formatter	J581	Cartridge memory tag
J542	Laser/scanner		

Locations of major components

Figure 3-4 External view

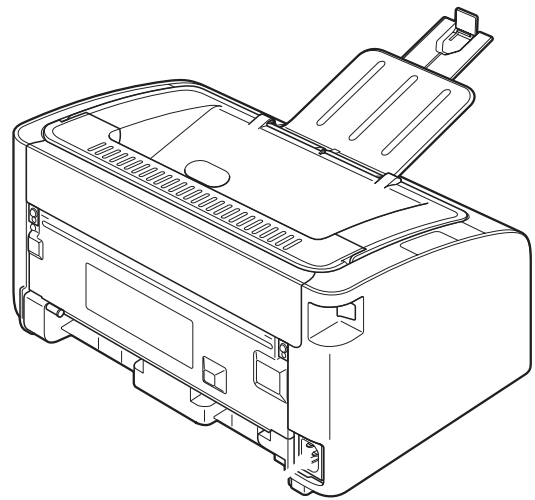
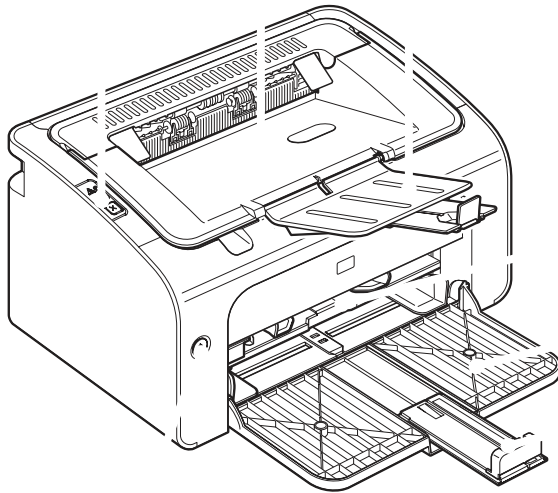

Item	Description	Item	Description
1	Cancel button (HP LaserJet Professional P1100w Printer series only)	5	Input tray or main-input tray NOTE: The HP LaserJet Professional P1100 Printer series has a single input tray. The HP LaserJet Professional P1100w Printer series has a main-input tray and a priority input slot.
2	Output bin (face-down tray)	6	Media-end plate

Item	Description	Item	Description
3	Output bin tray extension	7	Power switch
4	Priority input slot (HP LaserJet Professional P1100w Printer series only)	8	Power receptacle

Figure 3-5 Cross section view

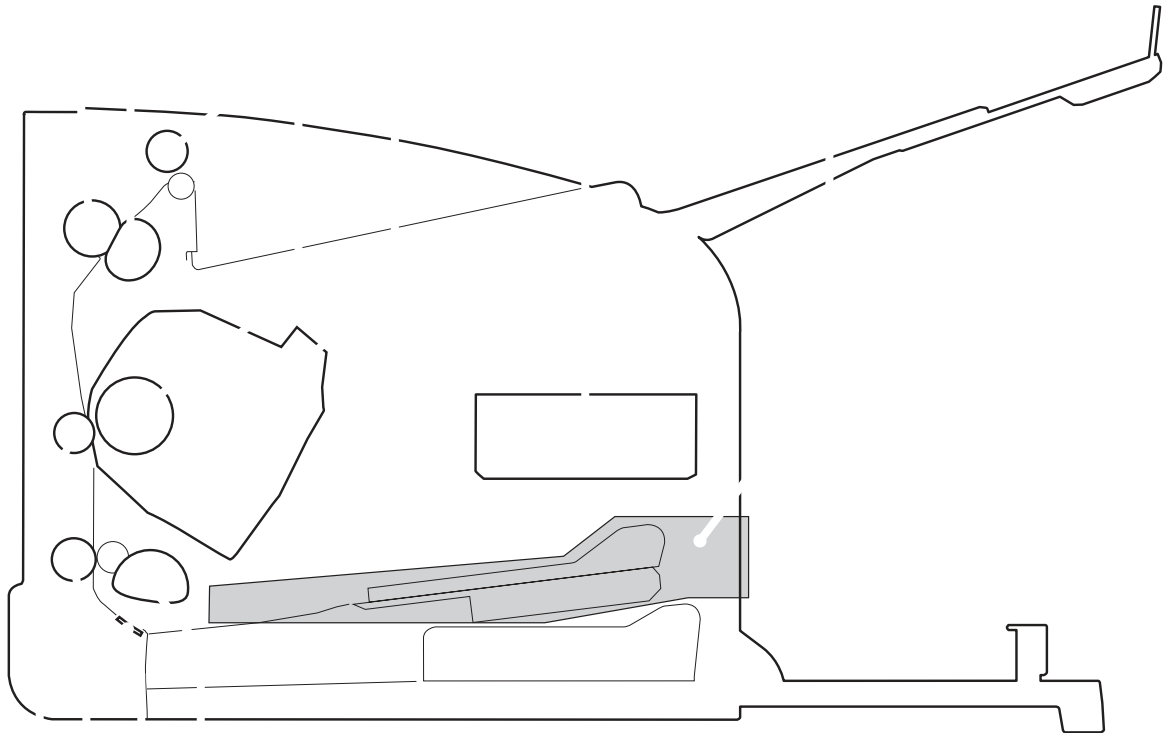

Item	Description	Item	Description
1	Pressure roller	7	Priority input slot (HP LaserJet Professional P1100w Printer series only)
2	Fuser film assembly	8	Pickup roller
3	Delivery roller	9	Separation pad
4	Photosensitive drum	10	Feed roller
5	Print cartridge	11	Transfer roller
6	Laser/scanner		

General timing charts

Figure 3-6 General timing diagram

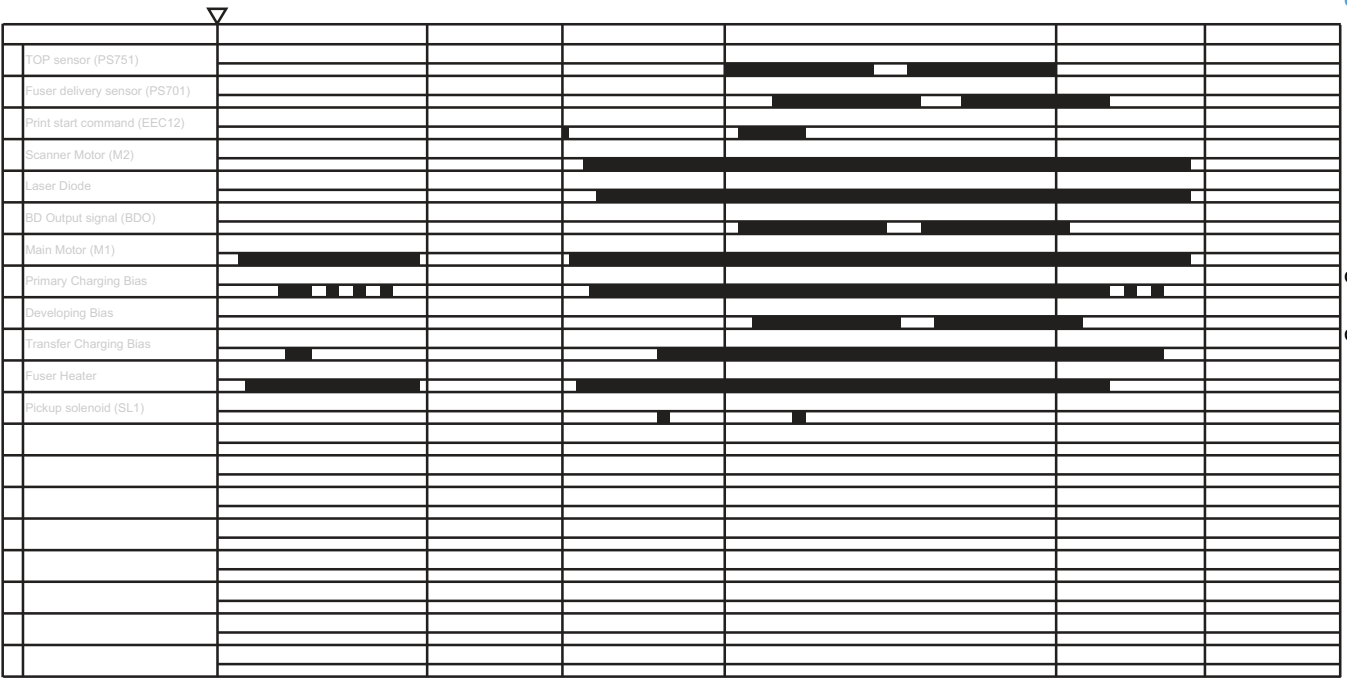

General circuit diagram

Figure 3-7 Circuit diagram: HP LaserJet Professional P1100 Printer series

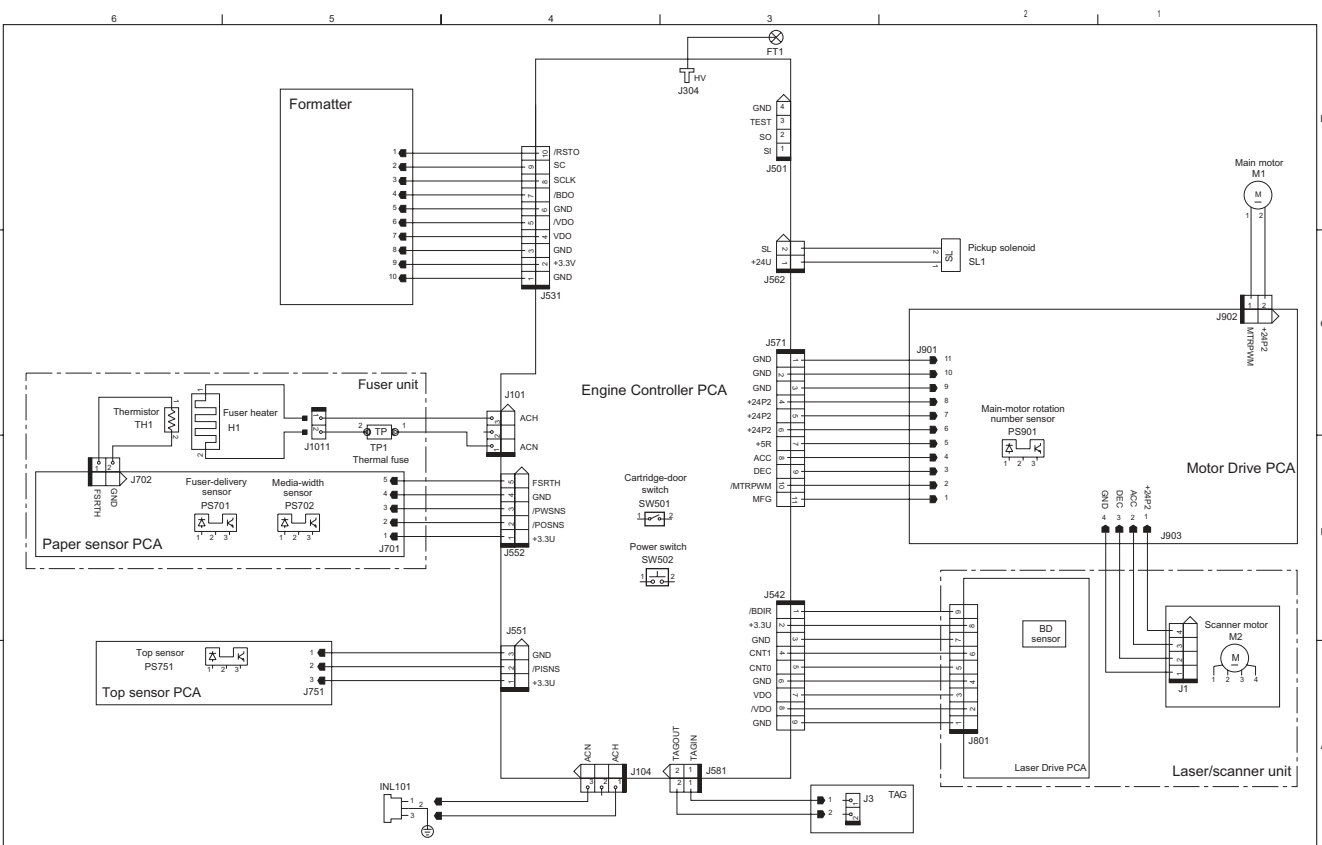

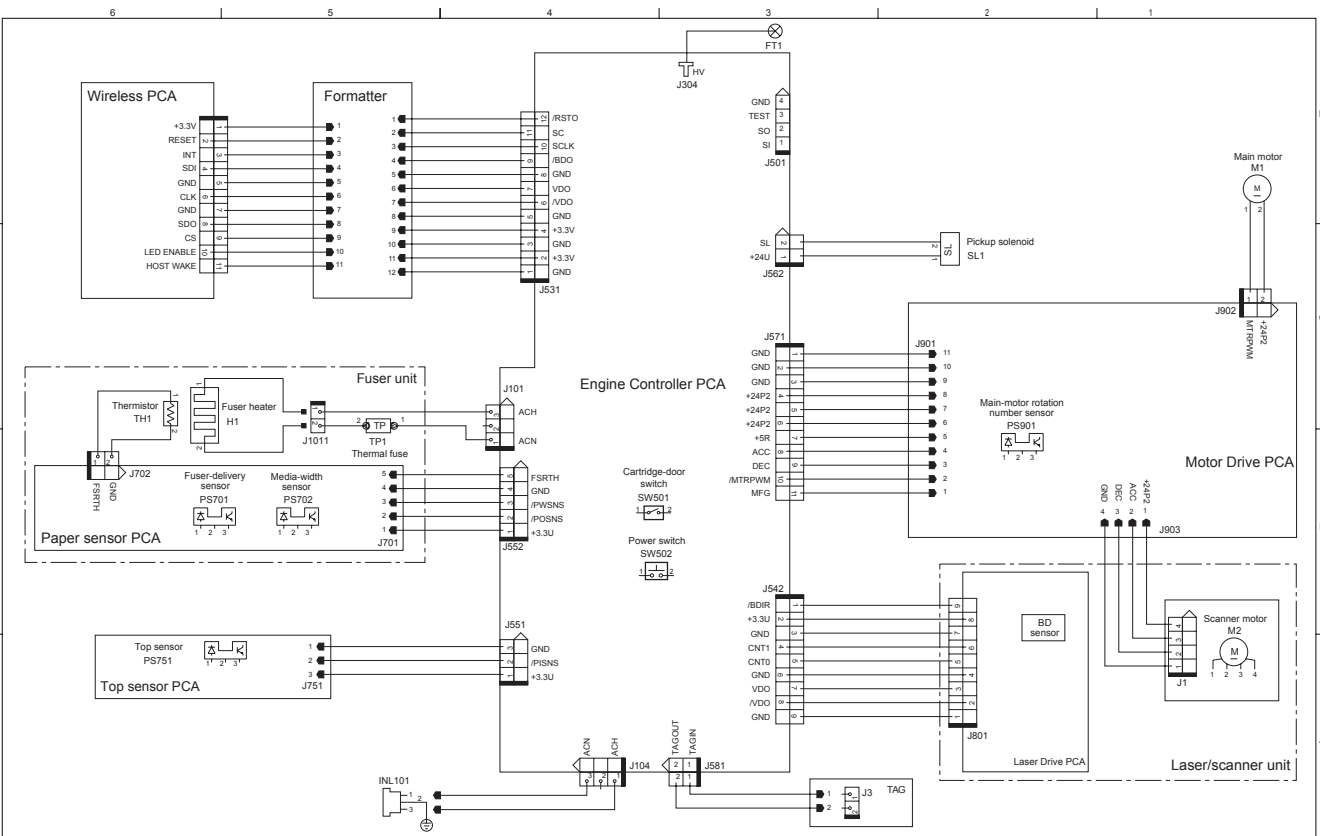
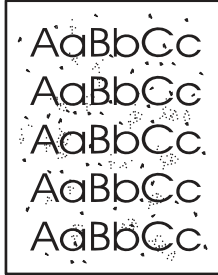



Figure 3-8 Circuit diagram; HP LaserJet Professional P1100w Printer series

Internal print-quality test pages



Cleaning page

If you are experiencing toner specks or dots on the printouts, clean the paper path. This process uses a transparency to remove dust and toner from the paper path. Do not use bond or rough paper.



 **NOTE:** For best results use a sheet of transparency. If you do not have any transparencies, you can use copier-grade paper (60 to 163 g/m² (16 to 43 lb)) that has a smooth surface.

1. Make sure that the product is idle and the ready light  is on.

 **NOTE:** If the product is in the auto-off state, the ready light  is off.

2. Load paper in the input tray.
3. Open the product **Properties**.
4. Click the **Device Settings** tab.
5. In the **Cleaning Page** area, click the **Start** button to process the cleaning page.



 **NOTE:** The cleaning process takes about 2 minutes. The cleaning page stops periodically during the cleaning process. Do not turn the product off until the cleaning process has finished. You might need to repeat the cleaning process several times to thoroughly clean the product.

Configuration page

The configuration page lists current product settings and properties. It also contains a status log report. To print a configuration page, do the following:

1. Open the printer driver, and then click the **Properties** or **Preferences** button.
2. Click the **Services** tab, and then, in the **Print Information Pages** drop-down list, click the **Config Page** list item.
3. Click the **Print** button.

On wireless models, you can print the configuration page from the product control panel.

- ▲ At the control panel, press and hold the cancel  button until the ready  light starts blinking, and then release the button.

Print-quality troubleshooting tools

Repetitive defect ruler

If the product output has a consistent, repetitive defect, and then use the table in this section to determine which part needs to be replaced based on the measured distance between the repetitions of the defect.

Component	Distance between defects (mm)	Type of defects
Primary charging roller	About 27	Dirt on page Dropouts
Photosensitive drum	About 75	Dirt on page Dropouts
Developing roller	About 34	Dirt on page Dropouts
Transfer roller	About 39	Dropouts Dirt on the back of page
Fuser film	About 57	Dirt on page Dropouts Loose toner
Pressure roller	About 56	Dirt on the back of page Loose toner

Interpret control-panel light patterns

Table 3-2 Status-light legend



	Symbol for "light off"
	Symbol for "light on"
	Symbol for "light blinking"

Table 3-3 Control-panel light patterns









Light status	State of the product	Action
All lights are off.	The product is in Auto-Off mode or is turned off.	Press the power button to deactivate the Auto-Off mode or to turn on the product.
		
Status lights cycle	The status lights cycle during the formatter initialization period or when the product is processing a cleaning page.	No action is required. Wait for the initialization period to end. The product enters the ready state when the initialization period is finished.
		
Ready light is on, and attention light is off.	The product is in the ready state.	No action is required. The product is ready to receive a print job.
		
Ready light is blinking, and attention light is off.	The product is receiving or processing data.	No action is required. The product is receiving or processing a print job.
		

Table 3-3 Control-panel light patterns (continued)







Light status	State of the product	Action
<p>Attention light is blinking, and ready light is off.</p> 	<p>The product has experienced an error that can be corrected at the product, such as a jam, an open door, the absence of a print cartridge, or the absence of paper in the proper tray.</p>	<p>Inspect the product, determine the error, and then correct the error. If the error is the absence of paper in the proper tray or the product is in a manual feed mode, put the proper paper in the tray and follow the on-screen instructions, or open and close the print-cartridge door to resume printing.</p>
<p>Attention light is blinking, and ready light is on.</p> 	<p>The product has experienced a continual error from which it can recover on its own.</p>	<p>If the recovery is successful, the product continues to the processing data state and completes the job.</p> <p>If the recovery is unsuccessful, the product continues to the continuable error state. Try removing any paper from the paper path and turning the product power off, and then on again.</p>
<p>The attention and ready lights are on.</p> 	<p>The product has experienced a fatal error from which it cannot recover.</p>	<ol style="list-style-type: none"> 1. Turn off the product or disconnect the power cord from the product. 2. Wait 30 seconds, and then turn on the product or reconnect the power cord to the product. 3. Wait for the product to initialize. 4. If the error persists, contact customer support for more information. See Customer support on page 164.
<p>The wireless light is blinking.</p> 	<p>The product is attempting to locate a wireless network.</p>	<p>No action is required.</p>

Table 3-3 Control-panel light patterns (continued)

Light status	State of the product	Action
<p>The wireless light is on.</p> 	<p>The product is connected to a wireless network.</p>	<p>No action is required.</p>
<p>The wireless light is off.</p> 	<p>The product is not connected to a network, and the wireless unit in the product might be turned off.</p>	<p>If the light is off, the product is not connected to the network and the wireless unit in the product might be off. Press the wireless button to try connecting to the network, or run the Wireless Configuration utility to configure the product. See the product user guide. To verify that the product finds the network, print a configuration page. The product should have an IP address assigned to it.</p> <p>For information about connecting wirelessly to a network, see the product user guide.</p> <p>If the product remains unable to connect to the network, uninstall and then reinstall the product. If the error persists, contact a network administrator or see the user manual of the wireless router or access point.</p>

Clear jams

When clearing jams, be careful not to tear jammed paper. If a small piece of paper remains in the product, it could cause more jams.

Common causes of jams

- The input tray is loaded incorrectly or is too full.

 **NOTE:** When you add new paper, always remove all of the paper from the input tray and straighten the entire stack. This helps prevent multiple feeds and reduces jams.

- The paper does not meet HP specifications.
- The product might need to be cleaned to remove paper dust and other particles from the paper path.

Loose toner might remain in the product after a jam. This toner clears up after a few sheets print.

△ **CAUTION:** If you get any toner on your clothes, wash them in cold water. *Hot water permanently sets toner into the fabric.*

Jam locations

Jams can occur at the following locations in the product.

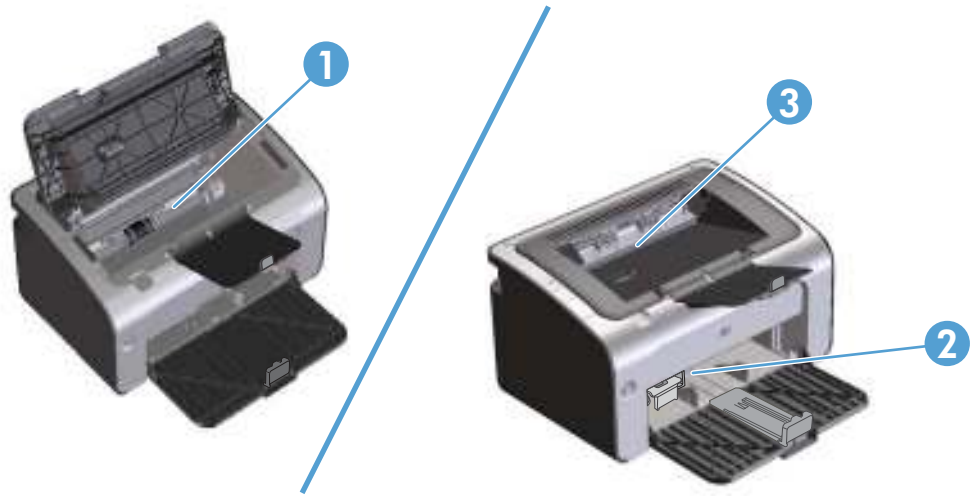

1	Internal areas
2	Input tray
3	Output bin

 **NOTE:** Jams can occur in more than one location.

Clear jams from the input tray

CAUTION: Do not use sharp objects, such as tweezers or needle-nose pliers, to remove jams. Damage caused by sharp objects is not covered by the warranty.

When removing jammed paper, pull the jammed paper straight away from the product. Pulling jammed paper out of the product at an angle can damage the product.

NOTE: Depending on where the jam is located, some of the following steps might not be necessary.

1. Open the print-cartridge door, and then remove the print cartridge.

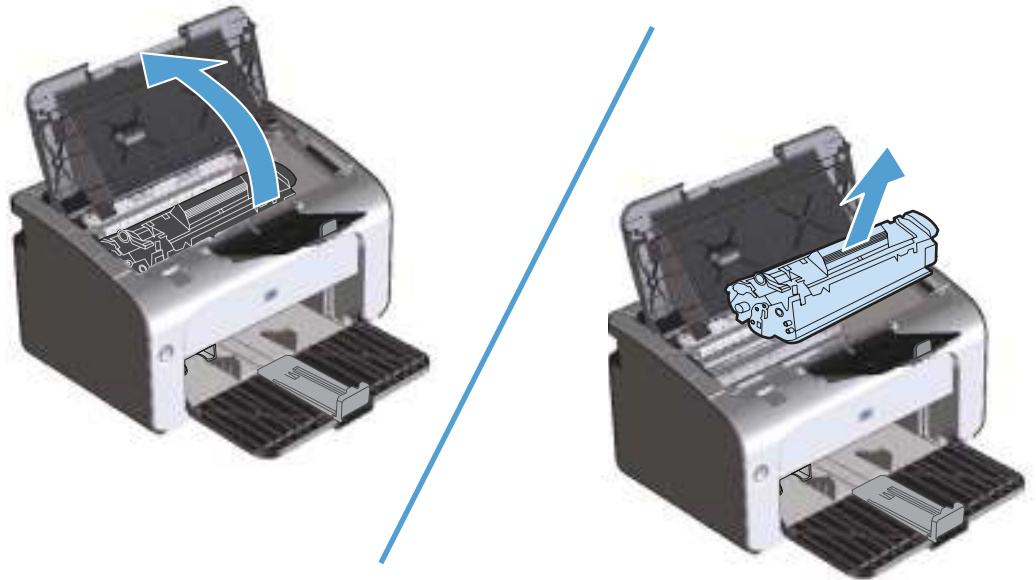

2. Remove the paper stack from the input tray.



3. With both hands, grasp the side of the jammed paper that is most visible (this includes the middle), and carefully pull it free from the product.



4. Reinstall the print cartridge, and then close the print-cartridge door.

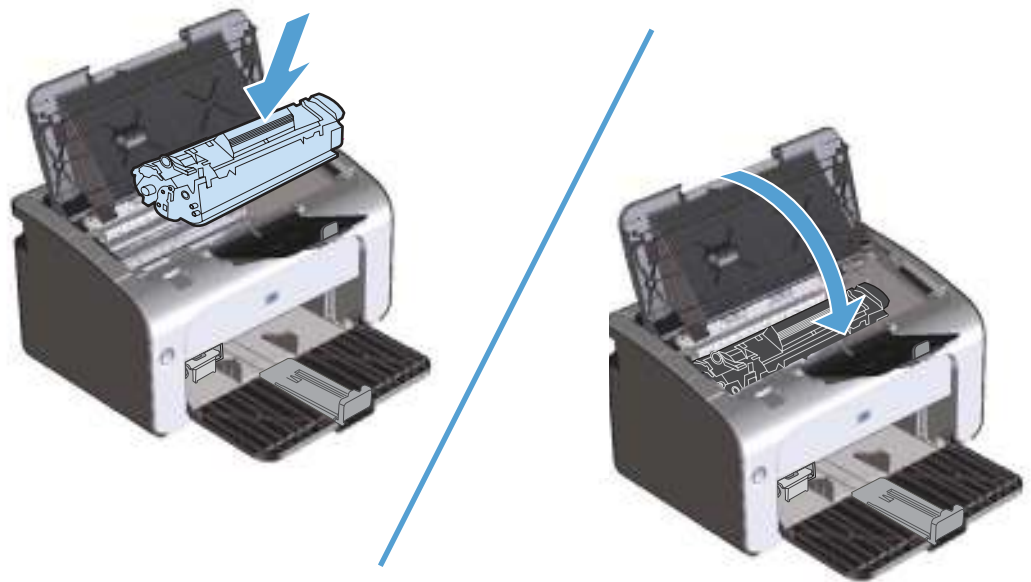

Clear jams from the output areas

CAUTION: Do not use sharp objects, such as tweezers or needle-nose pliers, to remove jams. Damage caused by sharp objects will not be covered by the warranty.

1. Open the print-cartridge door, and then remove the print cartridge.

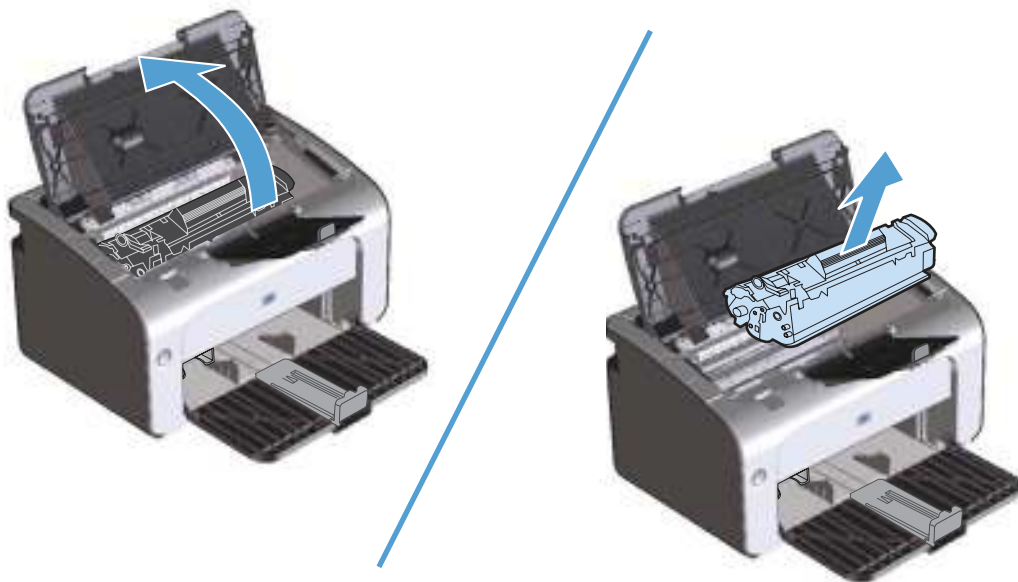

2. Keep the print cartridge door open, and then with both hands, grasp the side of the jammed paper that is most visible (this includes the middle), and carefully pull it free from the product.



3. Reinstall the print cartridge, and then close the print-cartridge door.

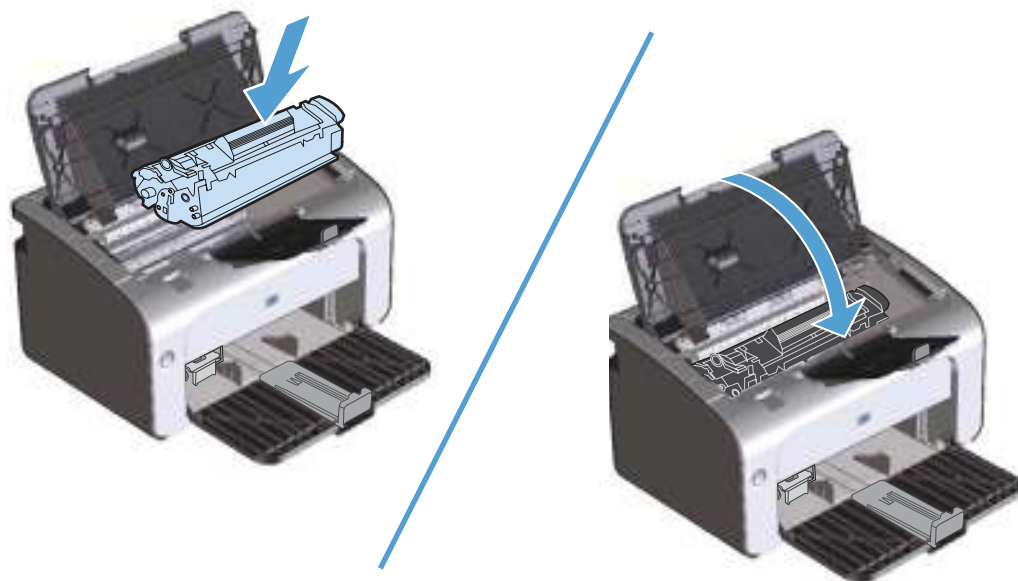

Clear jams from inside the product

1. Open the print-cartridge door, and then remove the print cartridge.

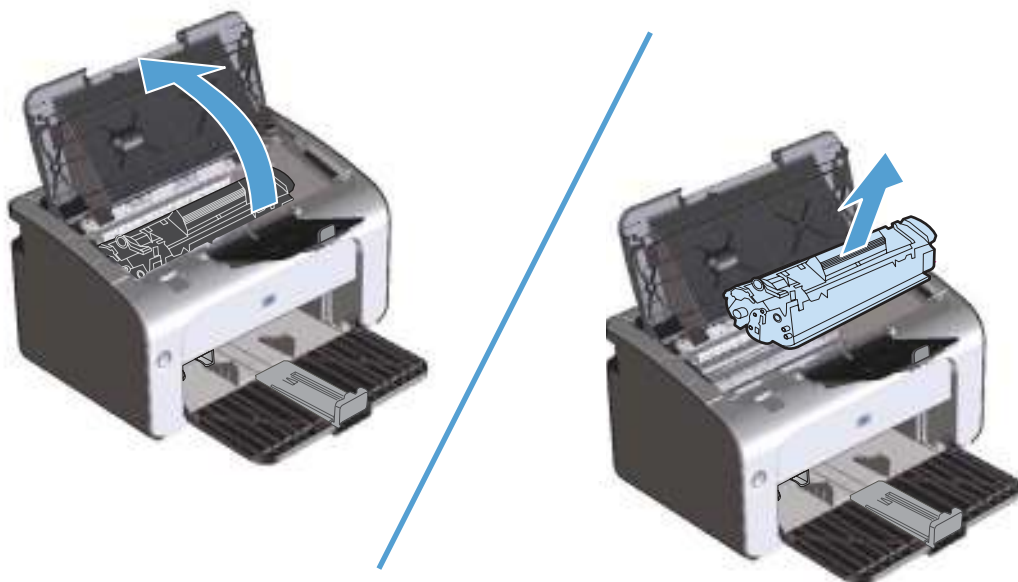

△ **CAUTION:** To prevent damage, do not expose the print cartridge to light. Cover it with a piece of paper.

2. If you can see the jammed paper, carefully grasp the jammed paper, and slowly pull it out of the product.



3. Reinstall the print cartridge, and then close the print-cartridge door.

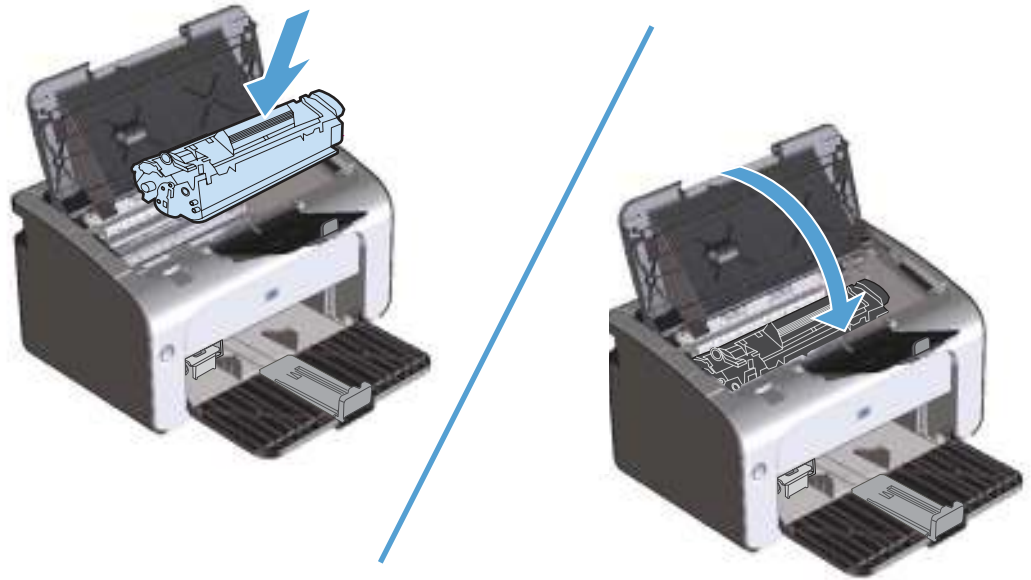

Solve repeated jams

- Verify that the input tray is not overfilled. The input tray capacity varies depending on the type of print paper that you are using.
- Verify that the paper guides are properly adjusted.
- Check that the input tray is securely in place.
- Do not add paper into the input tray while the product is printing.
- Use only HP-recommended paper types and sizes.
- Do not fan paper prior to loading it in a tray. To loosen the ream, hold it firmly in both hands and twist the paper by rotating your hands in the opposite direction.
- Do not let print paper stack up in the output bin. The print paper type and the amount of toner used affect the output bin capacity.
- Check the power connection. Make sure that the power cord is firmly connected to both the product and the power supply box. Plug the power cord into a grounded power outlet.

Change jam recovery

When the Jam Recovery feature is turned on, the product reprints any pages that are damaged during a jam.

1. Use the printer driver to change the default settings. Follow the appropriate procedure, depending on the operating system you are using.

Windows XP, Windows Server 2003, and Windows Server 2008 (using the default Start menu view)

- a. Click **Start**, and then click **Printers and Faxes**.
- b. Right-click the driver icon, and then select **Properties**.
- c. Click the **Device Settings** tab.

Windows XP, Windows Server 2003, and Windows Server 2008 (using the Classic Start menu view)

- a. Click **Start**, click **Settings**, and then click **Printers**.
- b. Right-click the driver icon, and then select **Properties**.
- c. Click the **Device Settings** tab.

Windows Vista and Windows 7

- a. Click **Start**, click **Control Panel**, and then in the category for **Hardware and Sound** click **Printer**.
- b. Right-click the driver icon, and then select **Properties**.
- c. Click the **Device Settings** tab.

Mac OS X 10.4

- a. From the Apple menu , click the **System Preferences** menu and then click the **Print & Fax** icon.
- b. Click the **Printer Setup** button.

Mac OS X 10.5 and 10.6

- a. From the Apple menu , click the **System Preferences** menu and then click the **Print & Fax** icon.
- b. Select the product in the left side of the window.
- c. Click the **Options & Supplies** button.
- d. Click the **Driver** tab.

2. Click the **Auto** option or the **Off** option under **Jam Recovery**.

Solve paper-handling problems

The following problems with paper cause print-quality deviations, jams, or damage to the product.

Problem	Cause	Solution
Poor print quality or toner adhesion	The paper is too moist, too rough, too heavy or too smooth, or it is embossed or from a faulty paper lot.	Try another kind of paper, between 100 and 250 Sheffield, with 4% to 6% moisture content.
Dropouts, jamming, or curl	The paper has been stored incorrectly.	Store paper flat in its moisture-proof wrapping.
	The paper has variability from one side to the other.	Turn the paper over.
Excessive curl	The paper is too moist, has the wrong grain direction, or is of short-grain construction.	Use long-grain paper.
	The paper varies from side-to-side.	Turn the paper over.
Jams, damage to product	The paper has cutouts or perforations.	Use paper that is free of cutouts or perforations.
Problems with feeding	The paper has ragged edges.	Use high-quality paper that is made for laser printers.
	The paper varies from side-to-side.	Turn the paper over.
	The paper is too moist, too rough, too heavy or too smooth, has the wrong grain direction, or is of short-grain construction or it is embossed or from a faulty paper lot.	Try another kind of paper, between 100 and 250 Sheffield, 4% to 6% moisture content. Use long-grain paper.
Print is skewed (crooked).	The paper guides might be incorrectly adjusted.	Remove all paper from the input tray, straighten the stack, and then load the paper in the input tray again. Adjust the paper guides to the width and length of the paper that you are using and try printing again.
More than one sheet feeds at one time.	The paper tray might be overloaded.	Remove some of the paper from the tray.
	The paper might be wrinkled, folded, or damaged.	Verify that the paper is not wrinkled, folded, or damaged. Try printing on paper from a new or different package.
The product does not pull paper from the input tray.	The product might be in manual-feed mode.	At the computer, follow the onscreen instructions to deactivate manual-feed mode. Or, at the product, open and close the print-cartridge door.
	The pickup roller might be dirty or damaged.	Clean the roller if it is dirty. Replace the roller if it is damaged. See Pickup roller on page 37 .
	The paper-length adjustment control in the input tray is set at a length that is greater than the paper size.	Set the paper-length adjustment control to the correct length.

Solve image-quality problems

You can prevent most print-quality problems by following these guidelines.

- Use paper that meets HP specifications.
- Clean the product as necessary. See [Clean the product on page 123](#).

Image defect table

This section provides information about identifying and correcting print defects.

Light print or faded

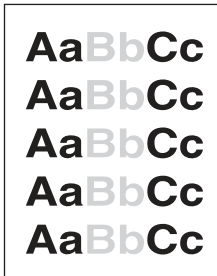

NOTE: The paper might not meet Hewlett-Packard's media specifications (for example, the paper is too moist or too rough).

1. If the whole page is light, the print density adjustment is too light or EconoMode might be turned on. Adjust the print density, and disable EconoMode in the product Properties.
2. Redistribute the toner to extend the life. Remove the print cartridge, and tip it from side to side lengthwise.

The print cartridge is nearing end of life. Install a new genuine HP print cartridge.

3. Open the print cartridge door during a print job and remove the print cartridge. Open the drum shield and check the toner on the drum surface.
 - If the toner image is not fully transferring to the paper, replace the transfer roller. See [Transfer roller on page 39](#).
 - If the toner image on the drum is faint, replace the laser/scanner. See [Laser/scanner assembly on page 58](#).

Toner specks

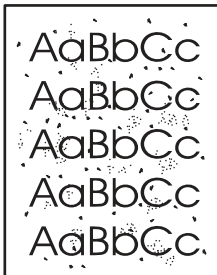

- The paper might not meet Hewlett-Packard's media specifications (for example, the paper is too moist or too rough).
- The product might need to be cleaned.
- The print cartridge might be defective. Install a new genuine HP print cartridge.

Dropouts

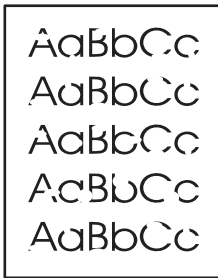

- A single sheet of paper might be defective. Try reprinting the job.
- The media moisture content is uneven or the paper has moist spots on its surface. Try printing with new paper.
- The paper lot is bad. The manufacturing processes can cause some areas to reject toner. Try a different type or brand of paper.
- The print cartridge might be defective. Install a new genuine HP print cartridge.

Vertical lines

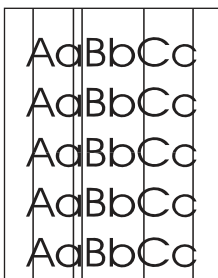

- Toner might be on the photosensitive drum. Print a few more pages to see if the problem might correct itself.
- The photosensitive drum inside the print cartridge has probably been scratched. Install a new genuine HP print cartridge.

Gray background

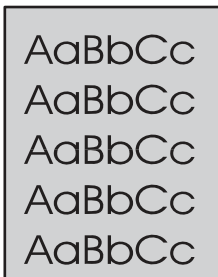

- Change the paper to a lighter basis weight.
- Check the product environment. Very dry (low humidity) conditions can increase the amount of background shading.
- The density setting might be too high. Adjust the density setting. See [Change print density on page 122](#)
- Install a new genuine HP print cartridge.

Toner smear

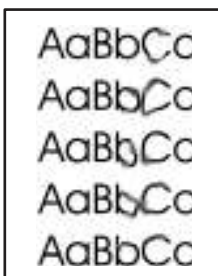

- If toner smears appear on the leading edge of the paper, the paper guides might be dirty. Wipe the paper guides with a dry, lint-free cloth.
- Check the paper type and quality.
- The fuser temperature might be too low. In the printer driver, make sure the appropriate paper type is selected.
- Try installing a new genuine HP print cartridge.

Loose toner

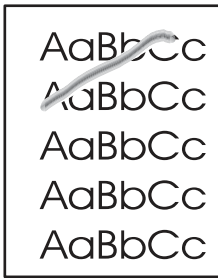

- The fuser temperature might be too low. In the printer driver, make sure the appropriate paper type is selected.
- Clean the inside of the product. See [Clean the product on page 123](#).
- Check the paper quality.
- Plug the product directly into an AC outlet instead of into a power strip.

Vertical repetitive defects

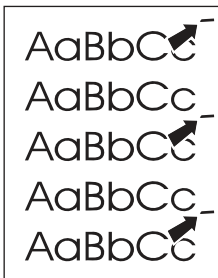

- The internal parts might have toner on them. If the defects occur on the back of the page, the problem probably will correct itself after a few more printed pages.
- In the printer driver, make sure the appropriate paper type is selected.
- A component might be damaged. If a repetitive mark occurs at the same spot on the page, use the repetitive defect ruler table to find the problem. See [Repetitive defect ruler on page 103](#).

Misformed characters

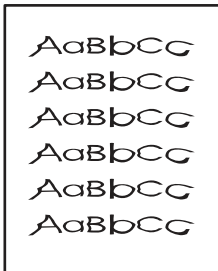

- If characters are improperly formed, producing hollow images, the paper stock might be too slick. Try a different paper.

Page skew

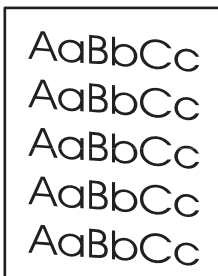

- Make sure that the paper is loaded correctly and the paper guides are not too tight or too loose against the paper stack.
- The input bin might be too full.
- Check the paper type and quality.

Curl or wave

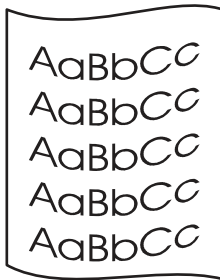

- Check the paper type and quality. Both high temperature and high humidity cause paper to curl.
- The paper might have been in the input tray too long. Turn over the stack of paper in the tray. Also, try rotating the paper 180° in the input tray.
- The fuser temperature might be too high. In the printer driver, make sure that the appropriate paper type is selected. If the problem persists, select a paper type that uses a lower fuser temperature, such as transparencies or light paper.

Wrinkles or creases

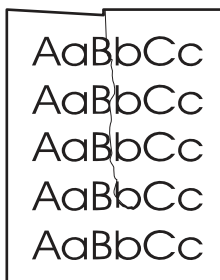

- Make sure that paper is loaded properly.
- Check the paper type and quality.
- Turn over the stack of paper in the tray. Also, try rotating the paper 180° in the input tray.
- For envelopes, this can be caused by air pockets inside the envelope. Remove the envelope, flatten the envelope, and then try printing again.

Toner scatter outline

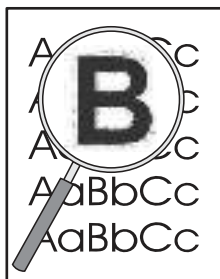

- If large amounts of toner have scattered around the characters, the transfer of toner to the paper is not optimal. (A small amount of toner scatter is normal for laser printing.) Try a different paper type setting in the printer driver, or use a different paper type.
- Turn over the stack of paper in the tray.
- Use paper that is designed for laser printers.

Moisture



NOTE: This product dissipates heat by using convective cooling. The heat and moisture generated by the printing process escape through vents in the product exterior or through the output bin area.

Verify normal product operation

The release of moisture is a result of normal product operation. However, HP recommends using the following steps to verify that the product is releasing steam and does not have a functional problem.

1. Turn the product off, and then on.
2. Send a print job to the product, and then verify that the product is operating correctly.
3. When printing a job and vapor is visible, immediately reprint the job using the same sheet of paper. There should be either no visible vapor, or much less vapor during the printing process.

Limit or reduce steam or vapor

- Make sure that the product is placed in a well-ventilated area that meets the environmental specifications.
- Do not place the product, or store paper, near an outside entrance where temperature changes can increase humidity.
- Use an unopened ream of paper that has not been exposed to high humidity.
- Store paper in an airtight container, where it will be less likely to absorb moisture.

Optimize and improve image quality

Change print density

You can change the print density setting by from the product properties dialog box.

1. **Windows XP, Windows Server 2008, and Windows Server 2003 (using the default Start menu view):** Click **Start**, and then click **Printers and Faxes**.

-or-

Windows XP, Windows Server 2008, and Windows Server 2003 (using the Classic Start menu view): Click **Start**, and then click **Printers**.

-or-

Windows Vista: Click **Start**, click **Control Panel**, and then in the category for **Hardware and Sound** click **Printer**.

-or-

Windows 7: Click **Start**, and then click **Devices and Printers**.

2. In the list of printers, right-click the name of this product, and then click the **Properties** menu item to open the product properties dialog box.
3. Click the **Device settings** tab, and then move the **Print Density** slider to the desired setting.
4. Click the **Apply** button to accept the setting, and then click the **OK** button to close the dialog box.

Clean the product

Clean the pickup roller

If you want to clean the pickup roller before deciding to replace it, follow these instructions:

1. Unplug the power cord from the product and remove the pickup roller. See [Pickup roller on page 37](#)
2. Dab a lint-free cloth in isopropyl alcohol, and scrub the roller.

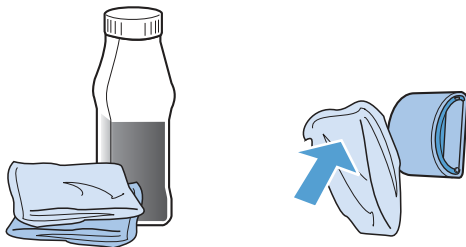

WARNING! Alcohol is flammable. Keep the alcohol and cloth away from an open flame. Before you close the product and plug in the power cord, allow the alcohol to dry completely.

NOTE: In certain areas of California, air pollution control regulations restrict the use of liquid Isopropyl Alcohol (IPA) as a cleaning agent. In those areas of California, disregard the previous recommendations and use a dry, lint-free cloth, moistened with water, to clean the pickup roller.

3. Use a dry, lint-free cloth, to wipe the pickup roller to remove loosened dirt.

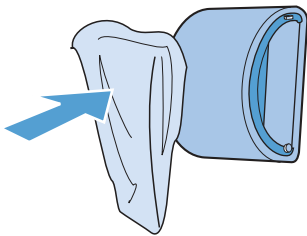

4. Allow the pickup roller to dry completely before you reinstall it in the product.

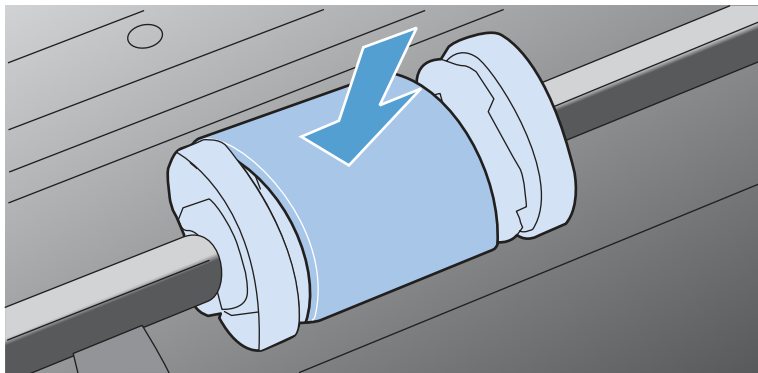

5. Reconnect the power cord.

Clean the paper path

If you are experiencing toner specks or dots on the printouts, clean the paper path. This process uses a transparency to remove dust and toner from the paper path. Do not use bond or rough paper.

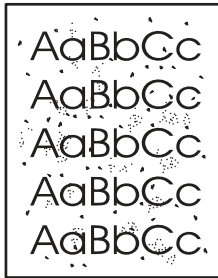

 **NOTE:** For best results use a sheet of transparency. If you do not have any transparencies, you can use copier-grade paper (60 to 163 g/m² (16 to 43 lb)) that has a smooth surface.

1. Make sure that the product is idle and the ready light is on.
2. Load paper in the input tray.
3. Use the printer driver to process the cleaning page. Follow the appropriate procedure, depending on the operating system you are using.

Windows XP, Windows Server 2003, and Windows Server 2008 (using the default Start menu view)

- a. Click **Start**, and then click **Printers and Faxes**.
- b. Right-click the driver icon, and then select **Properties**.
- c. Click the **Device Settings** tab.

Windows XP, Windows Server 2003, and Windows Server 2008 (using the Classic Start menu view)

- a. Click **Start**, click **Settings**, and then click **Printers**.
- b. Right-click the driver icon, and then select **Properties**.
- c. Click the **Device Settings** tab.

Windows Vista and Windows 7

- a. Click **Start**, click **Control Panel**, and then in the category for **Hardware and Sound** click **Printer**.
- b. Right-click the driver icon, and then select **Properties**.
- c. Click the **Device Settings** tab.

Mac OS X 10.4

- a. From the Apple menu , click the **System Preferences** menu and then click the **Print & Fax** icon.
- b. Click the **Printer Setup** button.

Mac OS X 10.5 and 10.6

- a. From the Apple menu , click the **System Preferences** menu and then click the **Print & Fax** icon.
 - b. Select the product in the left side of the window.
 - c. Click the **Options & Supplies** button.
 - d. Click the **Driver** tab.
4. In the **Cleaning Page** area, click the **Start** button to process the cleaning page.

 **NOTE:** The cleaning process takes about 2 minutes. The cleaning page stops periodically during the cleaning process. Do not turn the product off until the cleaning process has finished. You might need to repeat the cleaning process several times to thoroughly clean the product.

Clean the print-cartridge area

You do not need to clean the print-cartridge area often. However, cleaning this area can improve the quality of the printed sheets.

WARNING! Before changing the separation pad, turn the product off, disconnect the power cord from the wall outlet, and then wait for the product to cool.

1. Disconnect the power cord from the product. Open the print-cartridge door, and then remove the print cartridge.

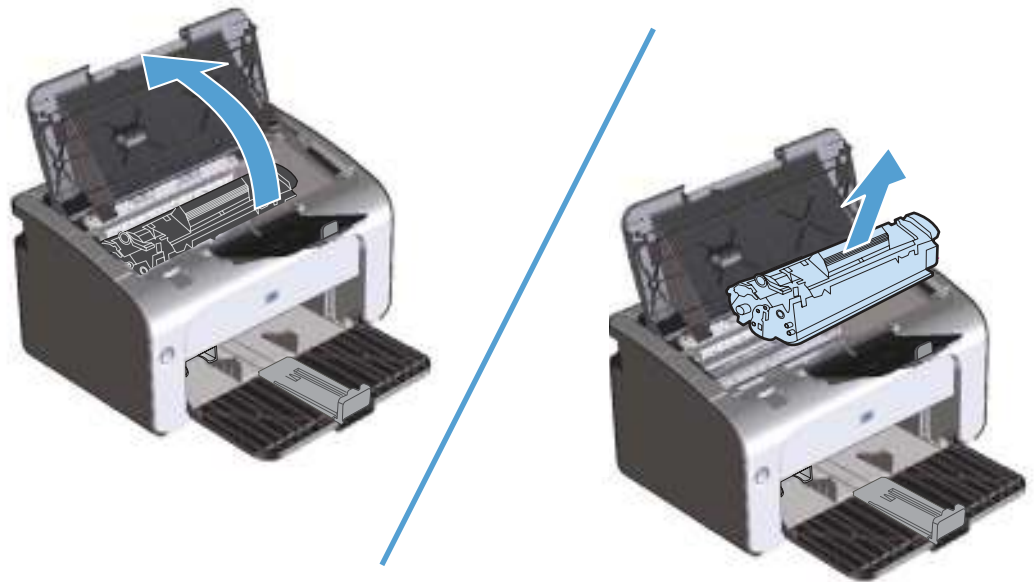

△ **CAUTION:** Do not touch the black-sponge transfer roller inside the product. Doing so can damage the product.

CAUTION: To prevent damage, do not expose the print cartridge to light. Cover it with a piece of paper.

2. With a dry, lint-free cloth, wipe any residue from the paper-path area and the print-cartridge cavity.



3. Reinstall the print cartridge, and then close the print-cartridge door.

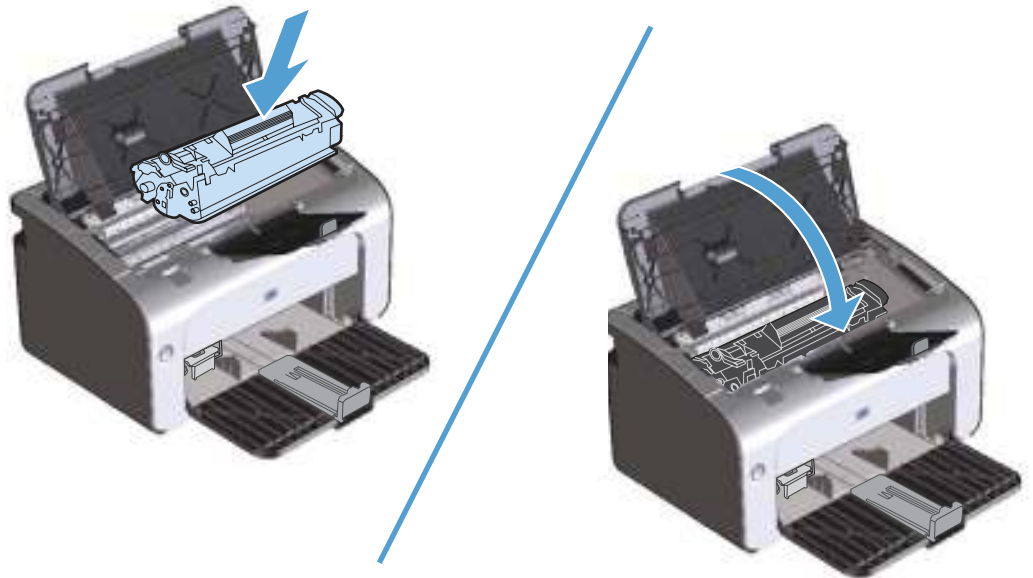

4. Disconnect the power cord.

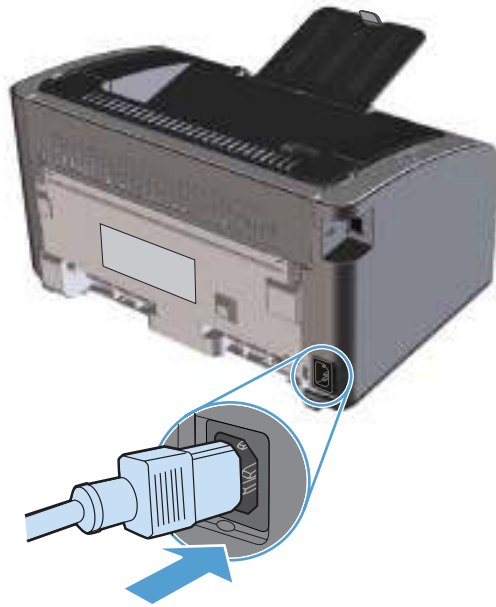

Clean the exterior

Use a soft, damp, lint-free cloth to wipe dust, smudges, and stains off of the exterior of the product.

Solve performance problems

Problem	Cause	Solution
Pages print, but are totally blank.	The cartridge pull tab or the sealing tape might still be in the print cartridge.	Verify that the cartridge pull tab and tape have been removed completely from the print cartridge.
	The document might contain blank pages.	Check the document that you are printing to see if content appears on all of the pages.
	The product might be malfunctioning.	To check the product, print a Configuration page.
Pages print very slowly.	Heavier paper types can slow the print job.	Print on a different type of paper.
	Complex pages can print slowly.	Proper fusing might require a slower print speed to make sure that the best print quality is achieved.
	Narrow or small paper can print slowly.	
	Using the FastRes 1200 print quality setting can cause slow printing.	<ol style="list-style-type: none"> 1. Open the print driver, and then click the Properties or Preferences button. 2. Click the Paper/Quality tab, and then use the Print Quality drop-down list to select a lower resolution setting. 3. Click the OK button or the Apply button to accept the setting.
Pages did not print.	The product might not be pulling paper correctly.	Make sure that paper is loaded in the tray correctly.
	The paper is jamming in the product.	Clear the jam. See Clear jams on page 107 .
	The USB cable might be defective or incorrectly connected.	<ul style="list-style-type: none"> • Disconnect the USB cable at both ends, and then reconnect it. • Try printing a job that has printed in the past. • Try using a different USB cable.
	Other devices are running on the computer.	The product might not share a USB port. If you have an external hard drive or switchbox that is connected to the same port as the product, the other product might be interfering. To connect and use the product, disconnect the other product, or use two USB ports on the computer.

Solve connectivity problems

Solve direct-connect problems

If you have connected the product directly to a computer, check the USB cable.

- Verify that the cable is connected to the computer and to the product.
- Verify that the cable is not longer than 2 m (6.56 ft). Replace the cable if necessary.
- Verify that the cable is working correctly by connecting it to another product. Replace the cable if necessary.

Solve wireless problems

 **NOTE:** HP LaserJet Professional P1100w Printer series only

The installation program cannot detect the product during the setup process.

Cause	Solution
The product is off.	Verify that the product is on and ready. Restart the product if necessary.
The product is too far away from the wireless router or access point.	Move the product closer to the wireless router or access point.
A personal firewall program is blocking communication.	Temporarily disable the firewall program to install the product. Re-enable the firewall program once the product installation is complete. If disabling the firewall allows you to communicate with the product, you might want to assign the product a static IP address, and then re-enable the firewall. For information about firewalls that are used in an HP environment, see www.hp.com/support/XP_firewall_information .
The product is not communicating with the wireless router or access point.	<ul style="list-style-type: none">• Verify that the wireless (ⓘ) light is on. If it is not on, press the wireless (ⓘ) button.• Move the product closer to the wireless router or access point, and then try again.• Restore the default wireless settings.<ol style="list-style-type: none">a. Turn the product off.b. Press and hold the wireless (ⓘ) button and the cancel ✕ button, and then turn the product on.c. Hold the buttons until all the lights blink in unison, and then release the buttons. <p>If the error persists, uninstall the product, and then re-run the installer program. When prompted for network settings, provide the settings, and then continue the installation.</p>

The product cannot connect to the wireless network.

Cause	Solution
The product wireless settings and the network settings do not match.	<p>You might need to configure the product network settings manually. Verify that you know the following network settings:</p> <ul style="list-style-type: none">• Communication mode• Network name (SSID)• Channel (ad-hoc networks only)• Authentication type <p>Use the Wireless Configuration utility to configure the product to print on wireless network.</p> <p>If the error persists, uninstall the product, and then re-run the installer program. When prompted for network settings, provide the settings, and then continue the installation.</p>
The wireless router or access point is configured with a media access control (MAC) filter that is denying the product access to the network.	Configure the wireless router or access point so that the list of accepted MAC addresses includes the product hardware address. Refer to the device owners manual for help.

The wireless connection is sometimes disabled.

Cause	Solution
<p>The product environment might be affecting wireless communication. The following situations can affect wireless communication:</p> <ul style="list-style-type: none">• A concrete or metal framed wall stands between the product and the wireless router or access point.• Televisions, computer appliances, microwave ovens, intercoms, mobile/cellular phones, battery chargers, and AC power adapters are installed close to the network.• A broadcast station or high-tension wire is located close to the network.• A fluorescent light that is near the network is being switched on or off.	Move the product to a location where it can receive a steady signal from the wireless router or access point. Or you might need to move the wireless router or access point.

Service mode functions

Product resets

HP LaserJet Professional P1100w Printer series only.

To restore the product to the factory-default settings, follow these steps.

 **NOTE:** This procedure does not reset page counts, service IDs, or other static product values.

1. Turn the product off.
2. Turn the product on, and while it is initializing press and hold the cancel **X** button and wireless **(i)** button at the same time for about 10 to 15 seconds (all of the LEDs will blink in unison until the buttons are released).

Product updates

Software and firmware updates and installation instructions for this product are available at www.hp.com/support/ljp1100series. Click **Downloads and drivers**, click the operating system, and then select the download for the product.

4 Parts and diagrams

- [Order parts by authorized service providers](#)
- [How to use the parts lists and diagrams](#)
- [Assembly locations](#)
- [Covers](#)
- [Internal assemblies](#)
- [PCAs](#)
- [Alphabetical parts list](#)
- [Numerical parts list](#)

Order parts by authorized service providers

Order parts, accessories, and supplies

Table 4-1 Order parts, accessories, and supplies

Order supplies and paper	www.hp.com/go/suresupply
Order genuine HP parts or accessories	www.hp.com/buy/parts
Order through service or support providers	Contact an HP-authorized service or support provider.

Related documentation and software

Table 4-2 Related documentation and software

Item	Description	Part number
<i>HP LaserJet P1100 Printer series User Guide</i>	Product user guide.	CE651-90901
<i>HP LaserJet P1100 Printer series Service Manual</i>	English service manual (this manual)	CE651-90953

Supplies part numbers

Table 4-3 Supplies part numbers

Item	Description	Part number
HP LaserJet print cartridge	Print cartridge	CE285A (new) CE285-67901 (service)

Customer self repair parts

Table 4-4 Customer replaceable units (CRU) kit part numbers

Item	Description	Part number
Kit, separation pad	Separation pad	CE651-67901
	Installation instructions	
Kit, pickup roller	Pickup roller	CE651-67902
	Installation instructions	

Service parts

 **NOTE:** The parts in the following table are not shown in the assembly illustrations in this chapter.

Item	Description	Part number
HP jewel	HP logo	7121-8265
Regulatory label	Blank label	5969-9497

Whole-unit replacement part numbers

Table 4-5 Whole-unit replacement part numbers

Item	Description	Part number
HP LaserJet Professional P1100 Printer series	220 V	CE651-67002 (new)
		CE651-69002 (exchange)
HP LaserJet Professional P1100w Printer series	110 V	CE657-67001 (new)
		CE657-69001 (exchange)
	220 V	CE657-67002 (new)
		CE657-69002 (exchange)

How to use the parts lists and diagrams

CAUTION: Be sure to order the correct part. When looking for part numbers for electrical components, pay careful attention to the voltage that is listed. Doing so will make sure that the part number selected is for the correct model.

 **NOTE:** In this manual, the abbreviation “PCA” stands for “printed circuit-board assembly.” Components described as a PCA might consist of a single circuit board or a circuit board plus other parts, such as cables and sensors.

The figures in this chapter show the major subassemblies in the product and their component parts. A parts list table follows each exploded view assembly diagram. Each table lists the item number, the associated part number, and the description of each part. If a part is not listed in the table, then it is not a field replacement unit (FRU).

Assembly locations

Base product

Figure 4-1 Base product

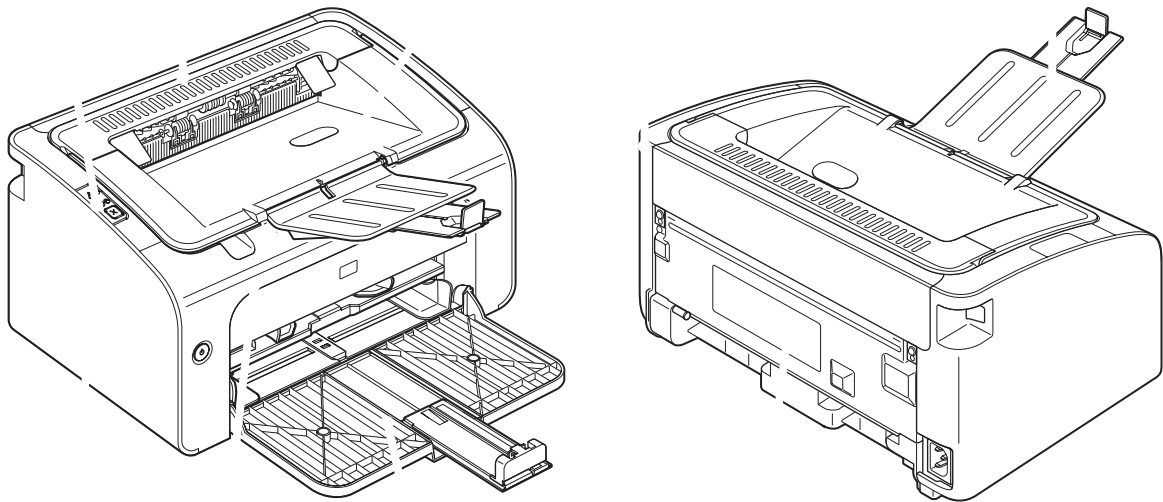

Table 4-6 Base product

Item	Description	Item	Description
1	Control panel	6	Rear cover
2	Face-down cover	7	Input tray or main-input tray NOTE: The HP LaserJet Professional P1100 Printer series has a single input tray. The HP LaserJet Professional P1100w Printer series has a main-input tray and a priority input slot.
3	Print-cartridge door	8	Front cover
4	Right cover	9	Left cover
5	Output bin tray extension		

Covers

Base model

Figure 4-2 Base model

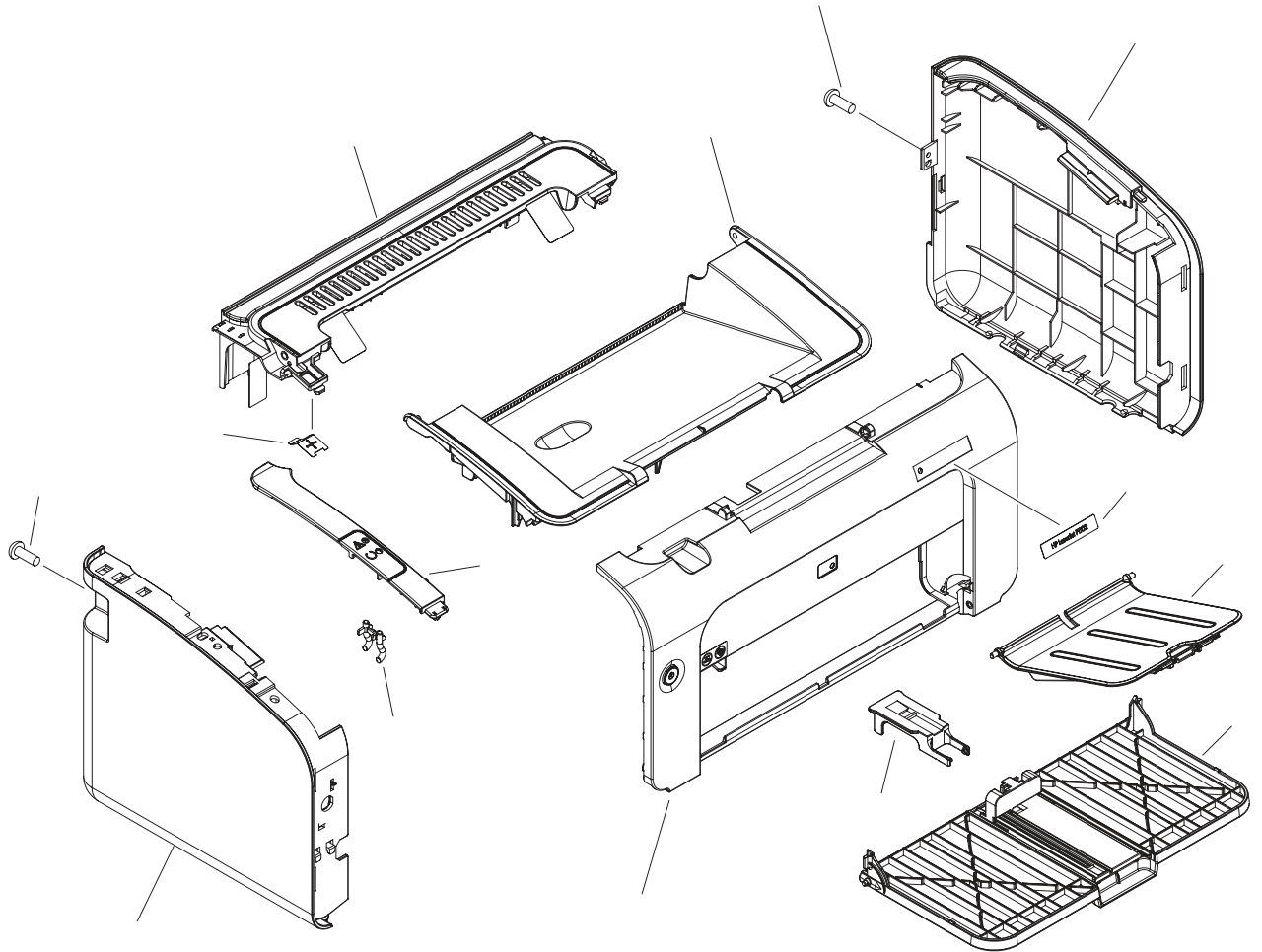

Table 4-7 Base model

Ref	Description	Part number	Qty
1	Front cover	RM1-6891-000CN	1
2	Paper pickup tray assembly	RM1-6899-000CN	1
3	Paper delivery tray assembly	RM1-6902-000CN	1
4	Face-down cover assembly	RM1-6889-000CN	1
5	Left cover assembly	RM1-6875-000CN	1
6	Right cover assembly	RM1-6890-000CN	1
7	Pipe, light	RC2-1108-000CN	1
8	Door, print cartridge	RC2-9237-000CN	1
9	Stopper, paper	RC2-9244-000CN	1
10	Plate, left	RL1-2991-000CN	1
11	Plate, name	RC3-0540-000CN	1

Wireless model

Figure 4-3 Wireless model

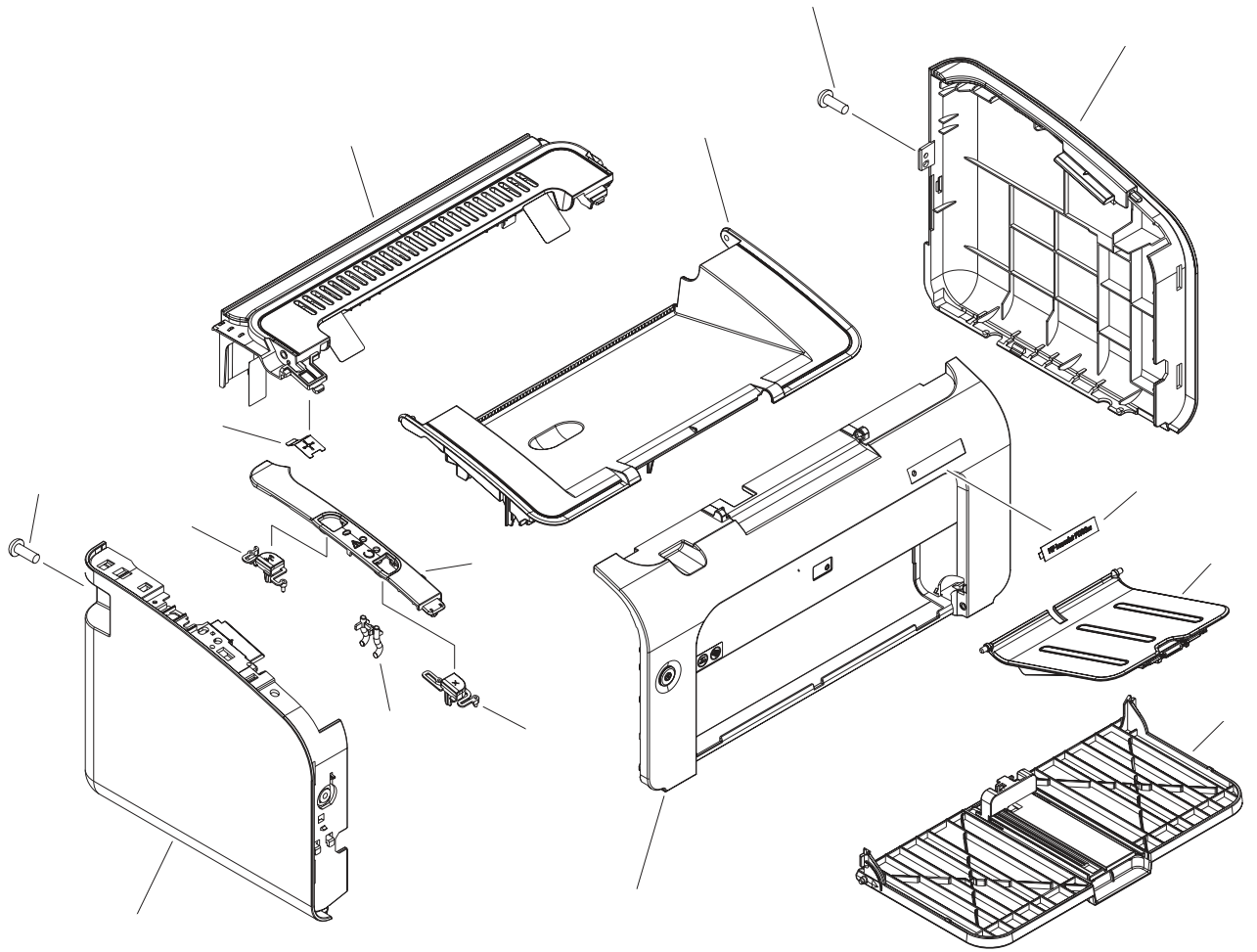

Table 4-8 Wireless model

Ref	Description	Part number	Qty
1	Front cover	RM1-6894-000CN	1
2	Paper pickup tray assembly	RM1-6901-000CN	1
3	Paper delivery tray assembly	RM1-6903-000CN	1
4	Face-down cover assembly	RM1-6892-000CN	1
5	Left cover assembly	RM1-6895-000CN	1
6	Right cover assembly	RM1-6893-000CN	1
7	Plate, left	RL1-2993-000CN	1
8	Button, cancel	RC2-9238-000CN	1
9	Pipe, light	RC3-0514-000CN	1
10	Door, print cartridge	RC3-0492-000CN	1
11	Button, Wi-Fi	RC3-0495-000CN	1
12	Plate, name	RC3-0543-000CN	1
12	Plate, name (for Brazil)	CE657-00001	

Internal assemblies

Internal assemblies (1 of 3)

Figure 4-4 Internal assemblies (1 of 3)

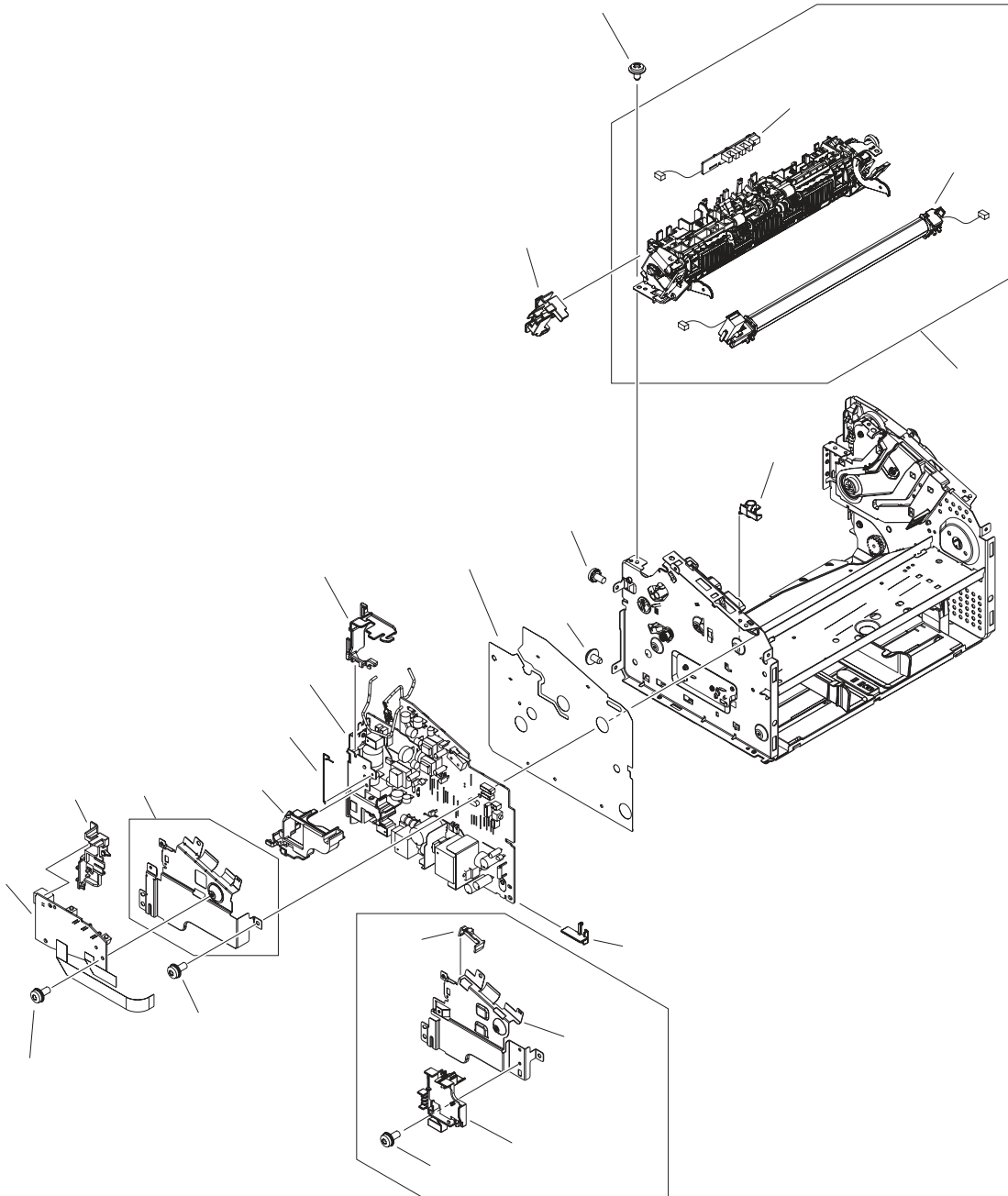

Table 4-9 Internal assemblies (1 of 3)

Ref	Description	Part number	Qty
1	Fuser delivery assembly (110 V)	RM1-6920-000CN	1
1	Fuser delivery assembly (220 V)	RM1-6921-000CN	1
2	Engine controller PCA, base model (220 V)	RM1-7591-000CN	1
2	Engine controller PCA, wireless model (110 V)	RM1-7595-000CN	1
2	Engine controller PCA, wireless model (220 V)	RM1-7596-000CN	1
3	Formatter PCA, base model	RM1-7600-000CN	1
3	Formatter PCA, wireless model	RM1-7601-000CN	1
4	Fuser film assembly (110 V)	RM1-6872-000CN	1
4	Fuser film assembly (220 V)	RM1-6873-000CN	1
5	Delivery sensor PCA assembly	RM1-8066-000CN	1

Internal assemblies (2 of 3)

Figure 4-5 Internal assemblies (2 of 3)

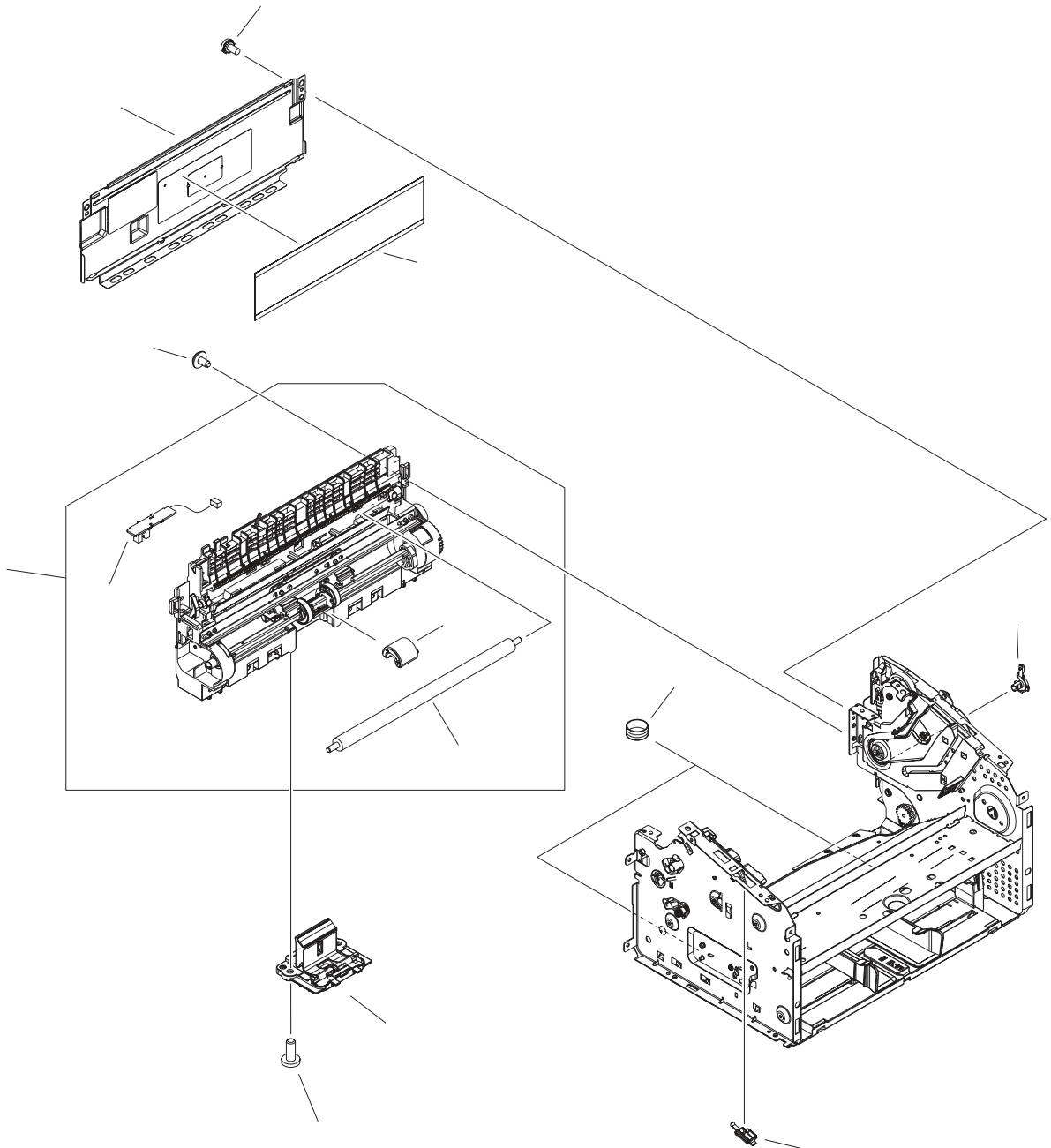

Table 4-10 Internal assemblies (2 of 3)

Ref	Description	Part number	Qty
1	Pickup transfer frame assembly, base model	RM1-6880-000CN	1
1	Pickup transfer frame assembly, wireless mode	RM1-6915-000CN	1
2	Transfer roller	RM1-4023-000CN	1
3	Separation pad assembly	RM1-4006-000CN	1
4	Panel, rear	RC2-1123-000CN	1
5	Roller, paper pickup	RL1-2593-000CN	1
6	Paper pickup sensor PCA assembly, base model	RM1-7593-000CN	1
6	Paper pickup sensor PCA assembly, wireless model	RM1-7598-000CN	1

Internal assemblies (3 of 3)

Figure 4-6 Internal assemblies (3 of 3)

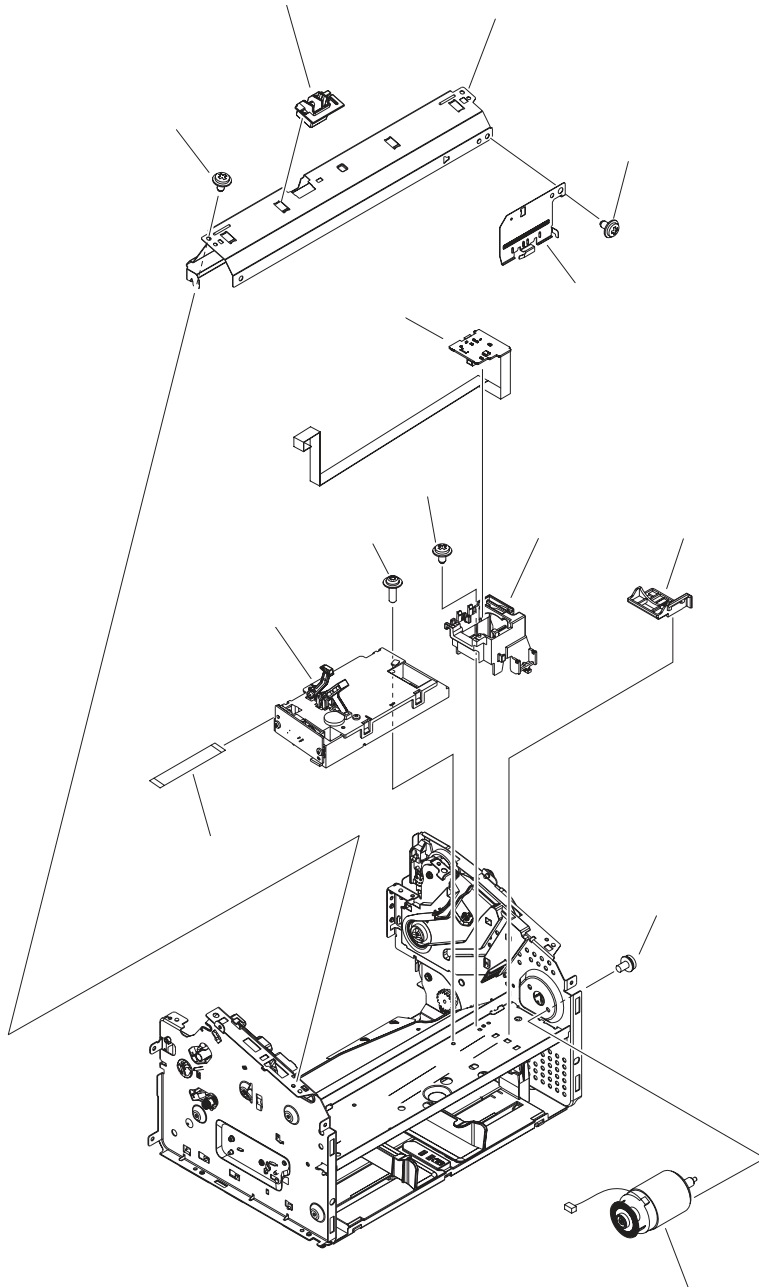

Table 4-11 Internal assemblies (3 of 3)

Ref	Description	Part number	Qty
1	Laser/scanner assembly	RM1-6878-000CN	1
2	Motor PCA, base model	RM1-7594-000CN	1
2	Motor PCA, wireless model	RM1-7599-000CN	1
3	Cable, flat (FFC)	RM1-7604-000CN	1
4	Motor, DC24V	RL1-2591-000CN	1

PCAs

Figure 4-7 PCAs

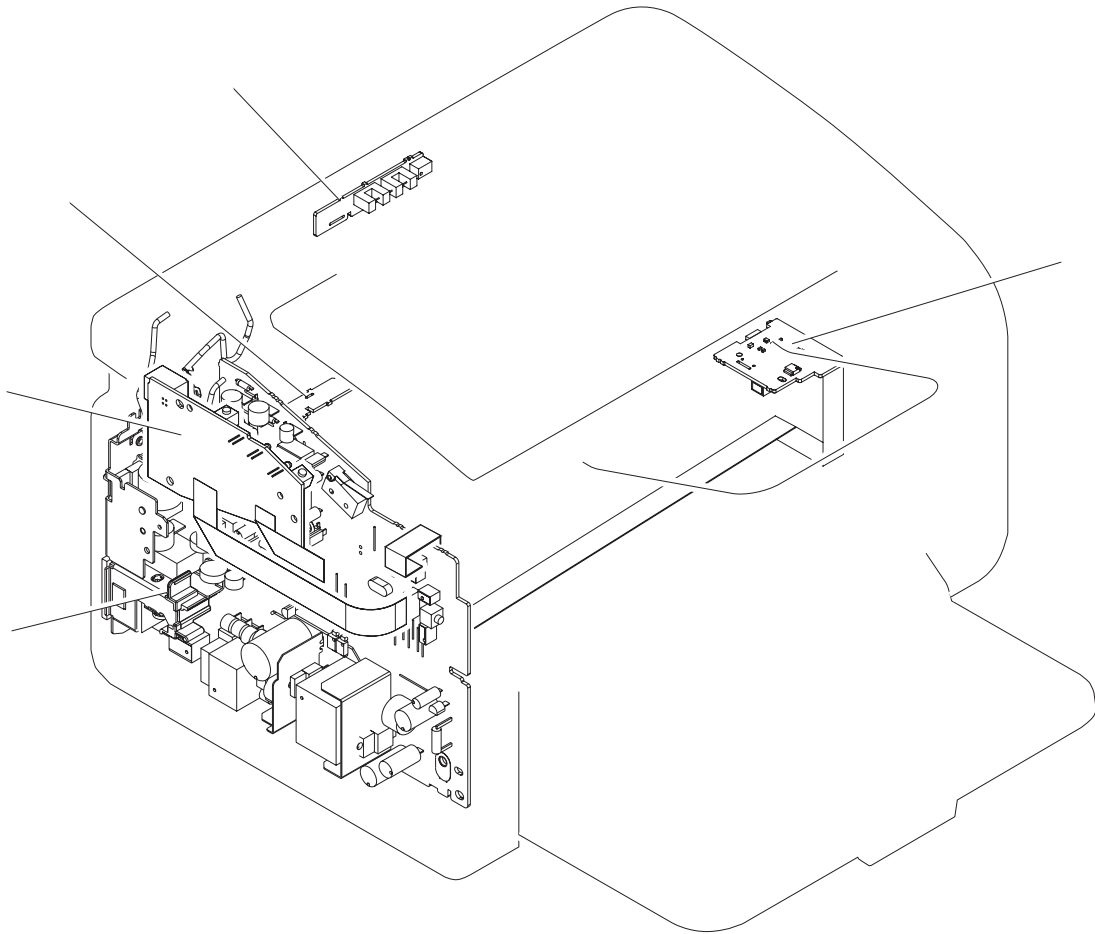

Table 4-12 PCAs

Ref	Description	Part number	Qty
1	Engine controller PCA, base model (220 V)	RM1-7591-000CN	1
1	Engine controller PCA, wireless model (220 V)	RM1-7596-000CN	1
2	Formatter PCA, base model	RM1-7600-000CN	1
2	Formatter PCA, wireless model	RM1-7601-000CN	1
2	Formatter PCA, wireless model (for Brazil)	CE670-60001	1
3	Motor PCA, base model	RM1-7594-000CN	1
3	Motor PCA, wireless model	RM1-7599-000CN	1
4	Delivery sensor PCA assembly	RM1-8066-000CN	1
5	Paper pickup sensor PCA assembly, base model	RM1-7593-000CN	1
5	Paper pickup sensor PCA assembly, wireless model	RM1-7598-000CN	1
Not shown	Wireless PCA	CE867-60001CN	1

Alphabetical parts list

Table 4-13 Alphabetical parts list

Description	Part number	Table and page
Button, cancel	RC2-9238-000CN	Wireless model on page 143
Button, Wi-Fi	RC3-0495-000CN	Wireless model on page 143
Cable, flat (FFC)	RM1-7604-000CN	Internal assemblies (3 of 3) on page 149
Delivery sensor PCA assembly	RM1-8066-000CN	Internal assemblies (1 of 3) on page 145
Delivery sensor PCA assembly	RM1-8066-000CN	PCAs on page 151
Door, print cartridge	RC2-9237-000CN	Base model on page 141
Door, print cartridge	RC3-0492-000CN	Wireless model on page 143
Engine controller PCA, base model (220 V)	RM1-7591-000CN	Internal assemblies (1 of 3) on page 145
Engine controller PCA, base model (220 V)	RM1-7591-000CN	PCAs on page 151
Engine controller PCA, wireless model (110 V)	RM1-7595-000CN	Internal assemblies (1 of 3) on page 145
Engine controller PCA, wireless model (220 V)	RM1-7596-000CN	Internal assemblies (1 of 3) on page 145
Engine controller PCA, wireless model (220 V)	RM1-7596-000CN	PCAs on page 151
Face-down cover assembly	RM1-6889-000CN	Base model on page 141
Face-down cover assembly	RM1-6892-000CN	Wireless model on page 143
Formatter PCA, base model	RM1-7600-000CN	Internal assemblies (1 of 3) on page 145
Formatter PCA, base model	RM1-7600-000CN	PCAs on page 151
Formatter PCA, wireless model	RM1-7601-000CN	Internal assemblies (1 of 3) on page 145
Formatter PCA, wireless model	RM1-7601-000CN	PCAs on page 151
Formatter PCA, wireless model (for Brazil)	CE670-60001	PCAs on page 151
Front cover	RM1-6891-000CN	Base model on page 141
Front cover	RM1-6894-000CN	Wireless model on page 143
Fuser delivery assembly (110 V)	RM1-6920-000CN	Internal assemblies (1 of 3) on page 145
Fuser delivery assembly (220 V)	RM1-6921-000CN	Internal assemblies (1 of 3) on page 145
Fuser film assembly (110 V)	RM1-6872-000CN	Internal assemblies (1 of 3) on page 145
Fuser film assembly (220 V)	RM1-6873-000CN	Internal assemblies (1 of 3) on page 145

Table 4-13 Alphabetical parts list (continued)

Description	Part number	Table and page
Laser/scanner assembly	RM1-6878-000CN	Internal assemblies (3 of 3) on page 149
Left cover assembly	RM1-6875-000CN	Base model on page 141
Left cover assembly	RM1-6895-000CN	Wireless model on page 143
Motor PCA, base model	RM1-7594-000CN	Internal assemblies (3 of 3) on page 149
Motor PCA, base model	RM1-7594-000CN	PCAs on page 151
Motor PCA, wireless model	RM1-7599-000CN	Internal assemblies (3 of 3) on page 149
Motor PCA, wireless model	RM1-7599-000CN	PCAs on page 151
Motor, DC24V	RL1-2591-000CN	Internal assemblies (3 of 3) on page 149
Panel, rear	RC2-1123-000CN	Internal assemblies (2 of 3) on page 147
Paper delivery tray assembly	RM1-6902-000CN	Base model on page 141
Paper delivery tray assembly	RM1-6903-000CN	Wireless model on page 143
Paper pickup sensor PCA assembly, base model	RM1-7593-000CN	Internal assemblies (2 of 3) on page 147
Paper pickup sensor PCA assembly, base model	RM1-7593-000CN	PCAs on page 151
Paper pickup sensor PCA assembly, wireless model	RM1-7598-000CN	Internal assemblies (2 of 3) on page 147
Paper pickup sensor PCA assembly, wireless model	RM1-7598-000CN	PCAs on page 151
Paper pickup tray assembly	RM1-6899-000CN	Base model on page 141
Paper pickup tray assembly	RM1-6901-000CN	Wireless model on page 143
Pickup transfer frame assembly, base model	RM1-6880-000CN	Internal assemblies (2 of 3) on page 147
Pickup transfer frame assembly, wireless mode	RM1-6915-000CN	Internal assemblies (2 of 3) on page 147
Pipe, light	RC2-1108-000CN	Base model on page 141
Pipe, light	RC3-0514-000CN	Wireless model on page 143
Plate, left	RL1-2991-000CN	Base model on page 141
Plate, left	RL1-2993-000CN	Wireless model on page 143
Plate, name	RC3-0540-000CN	Base model on page 141
Plate, name	RC3-0543-000CN	Wireless model on page 143
Plate, name (for Brazil)	CE657-00001	Wireless model on page 143
Right cover assembly	RM1-6890-000CN	Base model on page 141
Right cover assembly	RM1-6893-000CN	Wireless model on page 143
Roller, paper pickup	RL1-2593-000CN	Internal assemblies (2 of 3) on page 147

Table 4-13 Alphabetical parts list (continued)

Description	Part number	Table and page
Separation pad assembly	RM1-4006-000CN	Internal assemblies (2 of 3) on page 147
Stopper, paper	RC2-9244-000CN	Base model on page 141
Transfer roller	RM1-4023-000CN	Internal assemblies (2 of 3) on page 147
Wireless PCA	CE867-60001CN	PCAs on page 151

Numerical parts list

Table 4-14 Numerical parts list

Part number	Description	Table and page
CE657-00001	Plate, name (for Brazil)	Wireless model on page 143
CE670-60001	Formatter PCA, wireless model (for Brazil)	PCAs on page 151
CE867-60001CN	Wireless PCA	PCAs on page 151
RC2-1108-000CN	Pipe, light	Base model on page 141
RC2-1123-000CN	Panel, rear	Internal assemblies (2 of 3) on page 147
RC2-9237-000CN	Door, print cartridge	Base model on page 141
RC2-9238-000CN	Button, cancel	Wireless model on page 143
RC2-9244-000CN	Stopper, paper	Base model on page 141
RC3-0492-000CN	Door, print cartridge	Wireless model on page 143
RC3-0495-000CN	Button, Wi-Fi	Wireless model on page 143
RC3-0514-000CN	Pipe, light	Wireless model on page 143
RC3-0540-000CN	Plate, name	Base model on page 141
RC3-0543-000CN	Plate, name	Wireless model on page 143
RL1-2591-000CN	Motor, DC24V	Internal assemblies (3 of 3) on page 149
RL1-2593-000CN	Roller, paper pickup	Internal assemblies (2 of 3) on page 147
RL1-2991-000CN	Plate, left	Base model on page 141
RL1-2993-000CN	Plate, left	Wireless model on page 143
RM1-4006-000CN	Separation pad assembly	Internal assemblies (2 of 3) on page 147
RM1-4023-000CN	Transfer roller	Internal assemblies (2 of 3) on page 147
RM1-6872-000CN	Fuser film assembly (110 V)	Internal assemblies (1 of 3) on page 145
RM1-6873-000CN	Fuser film assembly (220 V)	Internal assemblies (1 of 3) on page 145
RM1-6875-000CN	Left cover assembly	Base model on page 141
RM1-6878-000CN	Laser/scanner assembly	Internal assemblies (3 of 3) on page 149
RM1-6880-000CN	Pickup transfer frame assembly, base model	Internal assemblies (2 of 3) on page 147
RM1-6889-000CN	Face-down cover assembly	Base model on page 141
RM1-6890-000CN	Right cover assembly	Base model on page 141
RM1-6891-000CN	Front cover	Base model on page 141

Table 4-14 Numerical parts list (continued)

Part number	Description	Table and page
RM1-6892-000CN	Face-down cover assembly	Wireless model on page 143
RM1-6893-000CN	Right cover assembly	Wireless model on page 143
RM1-6894-000CN	Front cover	Wireless model on page 143
RM1-6895-000CN	Left cover assembly	Wireless model on page 143
RM1-6899-000CN	Paper pickup tray assembly	Base model on page 141
RM1-6901-000CN	Paper pickup tray assembly	Wireless model on page 143
RM1-6902-000CN	Paper delivery tray assembly	Base model on page 141
RM1-6903-000CN	Paper delivery tray assembly	Wireless model on page 143
RM1-6915-000CN	Pickup transfer frame assembly, wireless mode	Internal assemblies (2 of 3) on page 147
RM1-6920-000CN	Fuser delivery assembly (110 V)	Internal assemblies (1 of 3) on page 145
RM1-6921-000CN	Fuser delivery assembly (220 V)	Internal assemblies (1 of 3) on page 145
RM1-7591-000CN	Engine controller PCA, base model (220 V)	Internal assemblies (1 of 3) on page 145
RM1-7591-000CN	Engine controller PCA, base model (220 V)	PCAs on page 151
RM1-7593-000CN	Paper pickup sensor PCA assembly, base model	Internal assemblies (2 of 3) on page 147
RM1-7593-000CN	Paper pickup sensor PCA assembly, base model	PCAs on page 151
RM1-7594-000CN	Motor PCA, base model	Internal assemblies (3 of 3) on page 149
RM1-7594-000CN	Motor PCA, base model	PCAs on page 151
RM1-7595-000CN	Engine controller PCA, wireless model (110 V)	Internal assemblies (1 of 3) on page 145
RM1-7596-000CN	Engine controller PCA, wireless model (220 V)	Internal assemblies (1 of 3) on page 145
RM1-7596-000CN	Engine controller PCA, wireless model (220 V)	PCAs on page 151
RM1-7598-000CN	Paper pickup sensor PCA assembly, wireless model	Internal assemblies (2 of 3) on page 147
RM1-7598-000CN	Paper pickup sensor PCA assembly, wireless model	PCAs on page 151
RM1-7599-000CN	Motor PCA, wireless model	Internal assemblies (3 of 3) on page 149
RM1-7599-000CN	Motor PCA, wireless model	PCAs on page 151
RM1-7600-000CN	Formatter PCA, base model	Internal assemblies (1 of 3) on page 145
RM1-7600-000CN	Formatter PCA, base model	PCAs on page 151
RM1-7601-000CN	Formatter PCA, wireless model	Internal assemblies (1 of 3) on page 145
RM1-7601-000CN	Formatter PCA, wireless model	PCAs on page 151

Table 4-14 Numerical parts list (continued)

Part number	Description	Table and page
RM1-7604-000CN	Cable, flat (FFC)	Internal assemblies (3 of 3) on page 149
RM1-8066-000CN	Delivery sensor PCA assembly	Internal assemblies (1 of 3) on page 145
RM1-8066-000CN	Delivery sensor PCA assembly	PCAs on page 151

A Service and support

- [Hewlett-Packard limited warranty statement](#)
- [HP's Premium Protection Warranty: LaserJet print cartridge limited warranty statement](#)
- [End User License Agreement](#)
- [Customer self-repair warranty service](#)
- [Customer support](#)
- [Repack the product](#)
- [Service information form](#)

Hewlett-Packard limited warranty statement

HP PRODUCT	DURATION OF LIMITED WARRANTY
HP LaserJet Professional P1100, P1100w	One year from date of purchase

HP warrants to you, the end-user customer, that HP hardware and accessories will be free from defects in materials and workmanship after the date of purchase, for the period specified above. If HP receives notice of such defects during the warranty period, HP will, at its option, either repair or replace products which prove to be defective. Replacement products may be either new or equivalent in performance to new.

HP warrants to you that HP software will not fail to execute its programming instructions after the date of purchase, for the period specified above, due to defects in material and workmanship when properly installed and used. If HP receives notice of such defects during the warranty period, HP will replace software which does not execute its programming instructions due to such defects.

HP does not warrant that the operation of HP products will be uninterrupted or error free. If HP is unable, within a reasonable time, to repair or replace any product to a condition as warranted, you will be entitled to a refund of the purchase price upon prompt return of the product.

HP products may contain remanufactured parts equivalent to new in performance or may have been subject to incidental use.

Warranty does not apply to defects resulting from (a) improper or inadequate maintenance or calibration, (b) software, interfacing, parts or supplies not supplied by HP, (c) unauthorized modification or misuse, (d) operation outside of the published environmental specifications for the product, or (e) improper site preparation or maintenance.

TO THE EXTENT ALLOWED BY LOCAL LAW, THE ABOVE WARRANTIES ARE EXCLUSIVE AND NO OTHER WARRANTY OR CONDITION, WHETHER WRITTEN OR ORAL, IS EXPRESSED OR IMPLIED AND HP SPECIFICALLY DISCLAIMS ANY IMPLIED WARRANTIES OR CONDITIONS OF MERCHANTABILITY, SATISFACTORY QUALITY, AND FITNESS FOR A PARTICULAR PURPOSE. Some countries/regions, states or provinces do not allow limitations on the duration of an implied warranty, so the above limitation or exclusion might not apply to you. This warranty gives you specific legal rights and you might also have other rights that vary from country/region to country/region, state to state, or province to province.

HP's limited warranty is valid in any country/region or locality where HP has a support presence for this product and where HP has marketed this product. The level of warranty service you receive may vary according to local standards. HP will not alter form, fit or function of the product to make it operate in a country/region for which it was never intended to function for legal or regulatory reasons.

TO THE EXTENT ALLOWED BY LOCAL LAW, THE REMEDIES IN THIS WARRANTY STATEMENT ARE YOUR SOLE AND EXCLUSIVE REMEDIES. EXCEPT AS INDICATED ABOVE, IN NO EVENT WILL HP OR ITS SUPPLIERS BE LIABLE FOR LOSS OF DATA OR FOR DIRECT, SPECIAL, INCIDENTAL, CONSEQUENTIAL (INCLUDING LOST PROFIT OR DATA), OR OTHER DAMAGE, WHETHER BASED IN CONTRACT, TORT, OR OTHERWISE. Some countries/regions, states or provinces do not allow the exclusion or limitation of incidental or consequential damages, so the above limitation or exclusion may not apply to you.

THE WARRANTY TERMS CONTAINED IN THIS STATEMENT, EXCEPT TO THE EXTENT LAWFULLY PERMITTED, DO NOT EXCLUDE, RESTRICT OR MODIFY AND ARE IN ADDITION TO THE MANDATORY STATUTORY RIGHTS APPLICABLE TO THE SALE OF THIS PRODUCT TO YOU.

HP's Premium Protection Warranty: LaserJet print cartridge limited warranty statement

This HP product is warranted to be free from defects in materials and workmanship.

This warranty does not apply to products that (a) have been refilled, refurbished, remanufactured or tampered with in any way, (b) experience problems resulting from misuse, improper storage, or operation outside of the published environmental specifications for the printer product or (c) exhibit wear from ordinary use.

To obtain warranty service, please return the product to place of purchase (with a written description of the problem and print samples) or contact HP customer support. At HP's option, HP will either replace products that prove to be defective or refund your purchase price.

TO THE EXTENT ALLOWED BY LOCAL LAW, THE ABOVE WARRANTY IS EXCLUSIVE AND NO OTHER WARRANTY OR CONDITION, WHETHER WRITTEN OR ORAL, IS EXPRESSED OR IMPLIED AND HP SPECIFICALLY DISCLAIMS ANY IMPLIED WARRANTIES OR CONDITIONS OF MERCHANTABILITY, SATISFACTORY QUALITY, AND FITNESS FOR A PARTICULAR PURPOSE.

TO THE EXTENT ALLOWED BY LOCAL LAW, IN NO EVENT WILL HP OR ITS SUPPLIERS BE LIABLE FOR DIRECT, SPECIAL, INCIDENTAL, CONSEQUENTIAL (INCLUDING LOST PROFIT OR DATA), OR OTHER DAMAGE, WHETHER BASED IN CONTRACT, TORT, OR OTHERWISE.

THE WARRANTY TERMS CONTAINED IN THIS STATEMENT, EXCEPT TO THE EXTENT LAWFULLY PERMITTED, DO NOT EXCLUDE, RESTRICT OR MODIFY AND ARE IN ADDITION TO THE MANDATORY STATUTORY RIGHTS APPLICABLE TO THE SALE OF THIS PRODUCT TO YOU.

End User License Agreement

PLEASE READ CAREFULLY BEFORE USING THIS SOFTWARE PRODUCT: This End-User License Agreement (“EULA”) is a contract between (a) you (either an individual or the entity you represent) and (b) Hewlett-Packard Company (“HP”) that governs your use of the software product (“Software”). This EULA does not apply if there is a separate license agreement between you and HP or its suppliers for the Software, including a license agreement in online documentation. The term “Software” may include (i) associated media, (ii) a user guide and other printed materials, and (iii) “online” or electronic documentation (collectively “User Documentation”).

RIGHTS IN THE SOFTWARE ARE OFFERED ONLY ON THE CONDITION THAT YOU AGREE TO ALL TERMS AND CONDITIONS OF THIS EULA. BY INSTALLING, COPYING, DOWNLOADING, OR OTHERWISE USING THE SOFTWARE, YOU AGREE TO BE BOUND BY THIS EULA. IF YOU DO NOT ACCEPT THIS EULA, DO NOT INSTALL, DOWNLOAD, OR OTHERWISE USE THE SOFTWARE. IF YOU PURCHASED THE SOFTWARE BUT DO NOT AGREE TO THIS EULA, PLEASE RETURN THE SOFTWARE TO YOUR PLACE OF PURCHASE WITHIN FOURTEEN DAYS FOR A REFUND OF THE PURCHASE PRICE; IF THE SOFTWARE IS INSTALLED ON OR MADE AVAILABLE WITH ANOTHER HP PRODUCT, YOU MAY RETURN THE ENTIRE UNUSED PRODUCT.

1. **THIRD PARTY SOFTWARE.** The Software may include, in addition to HP proprietary software (“HP Software”), software under licenses from third parties (“Third Party Software” and “Third Party License”). Any Third Party Software is licensed to you subject to the terms and conditions of the corresponding Third Party License. Generally, the Third Party License is located in a file such as license.txt; you should contact HP support if you cannot find any Third Party License. If the Third Party Licenses include licenses that provide for the availability of source code (such as the GNU General Public License) and the corresponding source code is not included with the Software, then check the product support pages of HP’s website (hp.com) to learn how to obtain such source code.

2. **LICENSE RIGHTS.** You will have the following rights provided you comply with all terms and conditions of this EULA:

a. **Use.** HP grants you a license to Use one copy of the HP Software. “Use” means installing, copying, storing, loading, executing, displaying, or otherwise using the HP Software. You may not modify the HP Software or disable any licensing or control feature of the HP Software. If this Software is provided by HP for Use with an imaging or printing product (for example, if the Software is a printer driver, firmware, or add-on), the HP Software may only be used with such product (“HP Product”). Additional restrictions on Use may appear in the User Documentation. You may not separate component parts of the HP Software for Use. You do not have the right to distribute the HP Software.

b. **Copying.** Your right to copy means you may make archival or back-up copies of the HP Software, provided each copy contains all the original HP Software’s proprietary notices and is used only for back-up purposes.

3. **UPGRADES.** To Use HP Software provided by HP as an upgrade, update, or supplement (collectively “Upgrade”), you must first be licensed for the original HP Software identified by HP as eligible for the Upgrade. To the extent the Upgrade supersedes the original HP Software, you may no longer use such HP Software. This EULA applies to each Upgrade unless HP provides other terms with the Upgrade. In case of a conflict between this EULA and such other terms, the other terms will prevail.

4. **TRANSFER.**

a. **Third Party Transfer.** The initial end user of the HP Software may make a one-time transfer of the HP Software to another end user. Any transfer will include all component parts, media, User Documentation, this EULA, and if applicable, the Certificate of Authenticity. The transfer may not be an indirect transfer, such as a consignment. Prior to the transfer, the end user receiving the transferred

Software will agree to this EULA. Upon transfer of the HP Software, your license is automatically terminated.

b. Restrictions. You may not rent, lease or lend the HP Software or Use the HP Software for commercial timesharing or bureau use. You may not sublicense, assign or otherwise transfer the HP Software except as expressly provided in this EULA.

5. PROPRIETARY RIGHTS. All intellectual property rights in the Software and User Documentation are owned by HP or its suppliers and are protected by law, including applicable copyright, trade secret, patent, and trademark laws. You will not remove any product identification, copyright notice, or proprietary restriction from the Software.

6. LIMITATION ON REVERSE ENGINEERING. You may not reverse engineer, decompile, or disassemble the HP Software, except and only to the extent that the right to do so is allowed under applicable law.

7. CONSENT TO USE OF DATA. HP and its affiliates may collect and use technical information you provide in relation to (i) your Use of the Software or the HP Product, or (ii) the provision of support services related to the Software or the HP Product. All such information will be subject to HP's privacy policy. HP will not use such information in a form that personally identifies you except to the extent necessary to enhance your Use or provide support services.

8. LIMITATION OF LIABILITY. Notwithstanding any damages that you might incur, the entire liability of HP and its suppliers under this EULA and your exclusive remedy under this EULA will be limited to the greater of the amount actually paid by you for the Product or U.S. \$5.00. TO THE MAXIMUM EXTENT PERMITTED BY APPLICABLE LAW, IN NO EVENT WILL HP OR ITS SUPPLIERS BE LIABLE FOR ANY SPECIAL, INCIDENTAL, INDIRECT, OR CONSEQUENTIAL DAMAGES (INCLUDING DAMAGES FOR LOST PROFITS, LOST DATA, BUSINESS INTERRUPTION, PERSONAL INJURY, OR LOSS OF PRIVACY) RELATED IN ANY WAY TO THE USE OF OR INABILITY TO USE THE SOFTWARE, EVEN IF HP OR ANY SUPPLIER HAS BEEN ADVISED OF THE POSSIBILITY OF SUCH DAMAGES AND EVEN IF THE ABOVE REMEDY FAILS OF ITS ESSENTIAL PURPOSE. Some states or other jurisdictions do not allow the exclusion or limitation of incidental or consequential damages, so the above limitation or exclusion may not apply to you.

9. U.S. GOVERNMENT CUSTOMERS. If you are a U.S. Government entity, then consistent with FAR 12.211 and FAR 12.212, Commercial Computer Software, Computer Software Documentation, and Technical Data for Commercial Items are licensed under the applicable HP commercial license agreement.

10. COMPLIANCE WITH EXPORT LAWS. You will comply with all laws, rules, and regulations (i) applicable to the export or import of the Software, or (ii) restricting the Use of the Software, including any restrictions on nuclear, chemical, or biological weapons proliferation.

11. RESERVATION OF RIGHTS. HP and its suppliers reserve all rights not expressly granted to you in this EULA.

(c) 2007 Hewlett-Packard Development Company, L.P.

Rev. 11/06

Customer self-repair warranty service

HP products are designed with many Customer Self Repair (CSR) parts to minimize repair time and allow for greater flexibility in performing defective parts replacement. If during the diagnosis period, HP identifies that the repair can be accomplished by the use of a CSR part, HP will ship that part directly to you for replacement. There are two categories of CSR parts: 1) Parts for which customer self repair is mandatory. If you request HP to replace these parts, you will be charged for the travel and labor costs of this service. 2) Parts for which customer self repair is optional. These parts are also designed for Customer Self Repair. If, however, you require that HP replace them for you, this may be done at no additional charge under the type of warranty service designated for your product.

Based on availability and where geography permits, CSR parts will be shipped for next business day delivery. Same-day or four-hour delivery may be offered at an additional charge where geography permits. If assistance is required, you can call the HP Technical Support Center and a technician will help you over the phone. HP specifies in the materials shipped with a replacement CSR part whether a defective part must be returned to HP. In cases where it is required to return the defective part to HP, you must ship the defective part back to HP within a defined period of time, normally five (5) business days. The defective part must be returned with the associated documentation in the provided shipping material. Failure to return the defective part may result in HP billing you for the replacement. With a customer self repair, HP will pay all shipping and part return costs and determine the courier/carrier to be used.

Customer support

Get telephone support for your country/region	Country/region phone numbers are on the flyer that was in the box with your product or at www.hp.com/support/ .
Have the product name, serial number, date of purchase, and problem description ready.	
Get 24-hour Internet support	www.hp.com/support/ljp1100series
Get support for products used with a Macintosh computer	www.hp.com/go/macosex
Download software utilities, drivers, and electronic information	www.hp.com/support/ljp1100series
Order additional HP service or maintenance agreements	www.hp.com/go/carepack

Repack the product

If HP Customer Care determines that your product needs to be returned to HP for repair, follow these steps to repack the product before shipping it.

CAUTION: Shipping damage as a result of inadequate packing is the customer's responsibility.

1. Remove and retain the print cartridge.

CAUTION: It is *extremely important* to remove the print cartridge before shipping the product. A print cartridge that remains in the product during shipping can leak and cover the product engine and other parts with toner.

To prevent damage to the print cartridge, avoid touching the roller on it, and store the print cartridge in its original packing material or so that it is not exposed to light.

2. Remove and retain the power cable, interface cable, and optional accessories, such as an EIO card.
3. If possible, include print samples and 50 to 100 sheets of paper or other print media that did not print correctly.
4. In the U.S., call HP Customer Care to request new packing material. In other areas, use the original packing material, if possible. Hewlett-Packard recommends insuring the equipment for shipment.

Service information form

WHO IS RETURNING THE EQUIPMENT? Date:

Person to contact: Phone:

Alternate contact: Phone:

Return shipping address: Special shipping instructions:

WHAT ARE YOU SENDING?

Model name: Model number: Serial number:

Please attach any relevant printouts. Do NOT ship accessories (manuals, cleaning supplies, and so on) that are not required to complete the repair.

HAVE YOU REMOVED THE PRINT CARTRIDGES?

You must remove them before shipping the product, unless a mechanical problem prevents you from doing so.

Yes. No, I cannot remove them.

WHAT NEEDS TO BE DONE? (Attach a separate sheet if necessary.)

1. Describe the conditions of the failure. (What was the failure? What were you doing when the failure occurred? What software were you running? Is the failure repeatable?)

2. If the failure is intermittent, how much time elapses between failures?

3. If the unit connected to any of the following, give the manufacturer and model number.

Personal computer: Modem: Network:

4. Additional comments:

HOW WILL YOU PAY FOR THE REPAIR?

Under warranty Purchase/received date:

(Attach proof of purchase or receiving document with original received date.)

Maintenance contract number:

Purchase order number:

Except for contract and warranty service, a purchase order number and/or authorized signature must accompany any request for service. If standard repair prices do not apply, a minimum purchase order is required. Standard repair prices can be obtained by contacting an HP-authorized repair center.

Authorized signature: Phone:

Billing address: Special billing instructions:

B Specifications

- [Physical specifications](#)
- [Power consumption](#)
- [Acoustic specifications](#)
- [Environmental specifications](#)

Physical specifications

Table B-1 Physical specifications¹

Specification	HP LaserJet Professional P1100 Printer series
Product weight	4.7 kg (10.4 lb)
Product height	194 mm (7.6 in)
Product depth	224 mm (8.8 in)
Product width	347 mm (13.7 in)

¹ Values are based on preliminary data. See www.hp.com/support/ljp1100series.

Power consumption

Table B-2 HP LaserJet Professional P1100 Printer series (average in watts)¹²³

Product	Printing	Ready	HP Auto Off	Manual Off
HP LaserJet Professional P1100 Printer series ⁴⁵	360	1.4	0.9	0.6
HP LaserJet Professional P1100w Printer series ⁴⁵	370	2.7	2.0	0.6

¹ Values are based on preliminary data. See www.hp.com/go/ljp1100_regulatory for current information.

² Power reported is highest values measured for all product models using all standard voltages.

³ Default time from Ready Mode to HP Auto Off = 5 minutes

⁴ Typical Electricity Consumption (TEC) = 0.505 kWh/week (HP LaserJet Professional P1100 Printer series); 0.704 kWh/week (HP LaserJet Professional P1100w Printer series)

⁵ Maximum heat dissipation for all models in Ready Mode = 5 BTU/Hour (HP LaserJet Professional P1100 Printer series); 10 BTU/Hour (HP LaserJet Professional P1100w Printer series)

Acoustic specifications

Table B-3 HP LaserJet Professional P1100 Printer series¹²

Sound power level	Declared per ISO 9296
Printing	L_{wAd} = 6.4 Bels (A) [64 dB(A)]
Ready	Inaudible
Sound pressure level - bystander position	Declared per ISO 9296
Printing	L_{pAm} = 50 dB (A)
Ready	Inaudible

¹ Values are based on preliminary data. See www.hp.com/go/ljp1100_regulatory for current information.

² Configuration tested: HP LaserJet P1102w product printing on A4-size paper in simplex mode

Environmental specifications

Table B-4 Environmental specifications

	Operating¹	Storage¹
Temperature	10° to 32.5°C (50° to 91°F)	0° to 35°C (32° to 95°F)
Relative Humidity	10% to 80%	10% to 80%

¹ Values are based on preliminary data. See www.hp.com/support/ljp1100series.

C Regulatory information

- [FCC regulations](#)
- [Declaration of conformity \(base models\)](#)
- [Declaration of conformity \(wireless models\)](#)
- [Certificate of Volatility](#)
- [Safety statements](#)
- [Additional statements for wireless products](#)

FCC regulations

This equipment has been tested and found to comply with the limits for a Class B digital device, pursuant to Part 15 of the FCC rules. These limits are designed to provide reasonable protection against harmful interference in a residential installation. This equipment generates, uses, and can radiate radio frequency energy. If this equipment is not installed and used in accordance with the instructions, it may cause harmful interference to radio communications. However, there is no guarantee that interference will not occur in a particular installation. If this equipment does cause harmful interference to radio or television reception, which can be determined by turning the equipment off and on, the user is encouraged to try to correct the interference by one or more of the following measures:

- Reorient or relocate the receiving antenna.
- Increase separation between equipment and receiver.
- Connect equipment to an outlet on a circuit different from that to which the receiver is located.
- Consult your dealer or an experienced radio/TV technician.

 **NOTE:** Any changes or modifications to the printer that are not expressly approved by HP could void the user's authority to operate this equipment.

Use of a shielded interface cable is required to comply with the Class B limits of Part 15 of FCC rules.

Declaration of conformity (base models)

according to ISO/IEC 17050-1 and EN 17050-1; DoC#: BOISB-0901-00-rel.1.0

Manufacturer's Name: Hewlett-Packard Company
Manufacturer's Address: 11311 Chinden Boulevard,
Boise, Idaho 83714-1021, USA

declares, that the product

Product Name: HP LaserJet P1100 Printer Series
Regulatory Model:²⁾ BOISB-0901-00
Product Options: All
Toner Cartridges: CE285A, CE284A, CE286A

conforms to the following Product Specifications:

SAFETY: IEC 60950-1:2001 / EN60950-1: 2001 +A11
IEC 60825-1:1993 +A1 +A2 / EN 60825-1:1994 +A1 +A2 (Class 1 Laser/LED Product)
GB4943-2001

EMC: CISPR22:2005 / EN55022:2006 +A1:2007 - Class B¹⁾
EN 61000-3-2:2006
EN 61000-3-3:1995 +A1 +A2
EN 55024:1998 +A1 +A2
FCC Title 47 CFR, Part 15 Class B / ICES-003, Issue 4
GB9254-1998, GB17625.1-2003

Supplementary Information:

The product herewith complies with the requirements of the EMC Directive 2004/108/EC and the Low Voltage Directive 2006/95/EC, and carries the CE-Marking  accordingly.

This Device complies with Part 15 of the FCC Rules. Operation is subject to the following two Conditions: (1) this device may not cause harmful interference, and (2) this device must accept any interference received, including interference that may cause undesired operation.

1) The product was tested in a typical configuration with Hewlett-Packard Personal Computer Systems.

2) For regulatory purposes, these products are assigned a Regulatory model number. This number should not be confused with the product name or the product number(s).

Boise, Idaho 83713, USA

October 2009

For Regulatory Topics Only:

European Contact Your Local Hewlett-Packard Sales and Service Office or Hewlett-Packard GmbH, Department HQ-TRE / Standards Europe, Herrenberger Straße 140, D-71034 Böblingen, Germany, (FAX: +49-7031-14-3143), <http://www.hp.com/go/certificates>

USA Contact Product Regulations Manager, Hewlett-Packard Company, PO Box 15, Mail Stop 160, Boise, ID 83707-0015, USA, (Phone: 208-396-6000)

Declaration of conformity (wireless models)

according to ISO/IEC 17050-1 and EN 17050-1; DoC#: BOISB-0901-01-rel.1.0

Manufacturer's Name: Hewlett-Packard Company
Manufacturer's Address: 11311 Chinden Boulevard,
Boise, Idaho 83714-1021, USA

declares, that the product

Product Name: HP LaserJet P1100 Series
Regulatory Model:²⁾ BOISB-0901-01
Product Options: All
Radio Module ³⁾ BOISB-0803-00
Toner Cartridges: CE285A, CE284A, CE286A

conforms to the following Product Specifications:

SAFETY: IEC 60950-1:2001 / EN60950-1: 2001 +A11
IEC 60825-1:1993 +A1 +A2 / EN 60825-1:1994 +A1 +A2 (Class 1 Laser/LED Product)
GB4943-2001

EMC: CISPR22:2005 / EN55022:2006 +A1:2007 - Class B¹⁾
EN 61000-3-2:2006
EN 61000-3-3:1995 +A1 +A2
EN 55024:1998 +A1 +A2
FCC Title 47 CFR, Part 15 Class B / ICES-003, Issue 4
GB9254-1998, GB17625.1-2003

RADIO³⁾: EN 301 489-1:V1.8.1 / EN 301 489-17:V1.3.2
EN 300 328:1.7.1
FCC Title 47 CFR, Part 15 Subpart C (Section 15.247) / IC: RSS-210

Supplementary Information:

The product herewith complies with the requirements of the R&TTE Directive 1999/5/EC Annex IV, EMC Directive 2004/108/EC and the Low Voltage Directive 2006/95/EC, and carries the CE-Marking  accordingly.

This Device complies with Part 15 of the FCC Rules. Operation is subject to the following two Conditions: (1) this device may not cause harmful interference, and (2) this device must accept any interference received, including interference that may cause undesired operation.

- 1) The product was tested in a typical configuration with Hewlett-Packard Personal Computer Systems.
- 2) For regulatory purposes, these products are assigned a Regulatory model number. This number should not be confused with the product name or the product number(s).
- 3) This product uses a radio module device which Regulatory Model number is BOISB-0803-00 as needed to meet technical regulatory requirements for the countries/regions this product will be sold.

Boise, Idaho 83713, USA

October 2009

For Regulatory Topics Only:

European Contact Your Local Hewlett-Packard Sales and Service Office or Hewlett-Packard GmbH, Department HQ-TRE / Standards Europe, Herrenberger Straße 140, D-71034 Böblingen, Germany, (FAX: +49-7031-14-3143), <http://www.hp.com/go/certificates>

USA Contact Product Regulations Manager, Hewlett-Packard Company, PO Box 15, Mail Stop 160, Boise, ID 83707-0015, USA, (Phone: 208-396-6000)

Certificate of Volatility

Model: LJ P1102		Part Number: CE651A		Address: 11311 Chinden Blvd. Boise, ID. 83714	
Does the device contain volatile memory (Memory whose contents are lost when power is removed)? <input checked="" type="checkbox"/> Yes <input type="checkbox"/> No If Yes please describe the type, size, function, and steps to clear the memory below					
Type (SRAM, DRAM, etc): Synchronous DRAM	Size: 2MB	Function: Run-time firmware image, print job info during printing		Steps to clear memory: Power off printer	
Type (SRAM, DRAM, etc):	Size:	Function:		Steps to clear memory:	
Type (SRAM, DRAM, etc):	Size:	Function:		Steps to clear memory:	
Does the device contain non-volatile memory (Memory whose contents are retained when power is removed)? <input checked="" type="checkbox"/> Yes <input type="checkbox"/> No If Yes please describe the type, size, function, and steps to clear the memory below					
Type (Flash, EEPROM, etc): EEPROM	Size: 2KB	Function: Printer Specific Data		Steps to clear memory: User cannot, service tools can.	
Type (Flash, EEPROM, etc): NAND Flash	Size: 64MB	Function: Printer Driver and Firmware		Steps to clear memory: User cannot, service tools can.	
Type (Flash, EEPROM, etc):	Size:	Function:		Steps to clear memory:	
Does the device contain mass storage memory (Hard Disk Drive, Tape Backup)? <input type="checkbox"/> Yes <input checked="" type="checkbox"/> No If Yes please describe the type, size, function, and steps to clear the memory below					
Type (HDD, Tape, etc):	Size:	Function:		Steps to clear memory:	
Type (HDD, Tape, etc):	Size:	Function:		Steps to clear memory:	
Name:		Title: Technical Marketing Engineer		Email:	
				Business Unit: LaserJet Business	
Date Prepared: 08/28/2009					

Model: LJ P1102w		Part Number: CE657A		Address: 11311 Chinden Blvd. Boise, ID. 83714	
Does the device contain volatile memory (Memory whose contents are lost when power is removed)? <input checked="" type="checkbox"/> Yes <input type="checkbox"/> No If Yes please describe the type, size, function, and steps to clear the memory below					
Type (SRAM, DRAM, etc): Synchronous DRAM	Size: 8MB	Function: Run-time firmware image, print job info during printing		Steps to clear memory: Power off printer	
Type (SRAM, DRAM, etc):	Size:	Function:		Steps to clear memory:	
Type (SRAM, DRAM, etc):	Size:	Function:		Steps to clear memory:	
Does the device contain non-volatile memory (Memory whose contents are retained when power is removed)? <input checked="" type="checkbox"/> Yes <input type="checkbox"/> No If Yes please describe the type, size, function, and steps to clear the memory below					
Type (Flash, EEPROM, etc): EEPROM	Size: 8KB	Function: Printer Specific Data		Steps to clear memory: User cannot, service tools can.	
Type (Flash, EEPROM, etc): NAND Flash	Size: 64MB	Function: Printer Driver and Firmware		Steps to clear memory: User cannot, service tools can.	
Type (Flash, EEPROM, etc):	Size:	Function:		Steps to clear memory:	
Does the device contain mass storage memory (Hard Disk Drive, Tape Backup)? <input type="checkbox"/> Yes <input checked="" type="checkbox"/> No If Yes please describe the type, size, function, and steps to clear the memory below					
Type (HDD, Tape, etc):	Size:	Function:		Steps to clear memory:	
Type (HDD, Tape, etc):	Size:	Function:		Steps to clear memory:	
Name:		Title: Technical Marketing Engineer		E mail:	
				Business Unit: LaserJet Business	
Date Prepared: 08/28/2009					

Safety statements

Laser safety

The Center for Devices and Radiological Health (CDRH) of the U.S. Food and Drug Administration has implemented regulations for laser products manufactured since August 1, 1976. Compliance is mandatory for products marketed in the United States. The device is certified as a “Class 1” laser product under the U.S. Department of Health and Human Services (DHHS) Radiation Performance Standard according to the Radiation Control for Health and Safety Act of 1968. Since radiation emitted inside the device is completely confined within protective housings and external covers, the laser beam cannot escape during any phase of normal user operation.

WARNING! Using controls, making adjustments, or performing procedures other than those specified in this user guide may result in exposure to hazardous radiation.

Canadian DOC regulations

Complies with Canadian EMC Class B requirements.

« Conforme à la classe B des normes canadiennes de compatibilité électromagnétiques. « CEM ». »

VCCI statement (Japan)

この装置は、情報処理装置等電波障害自主規制協議会（VCCI）の基準に基づくクラスB情報技術装置です。この装置は、家庭環境で使用することを目的としていますが、この装置がラジオやテレビジョン受信機に近接して使用されると、受信障害を引き起こすことがあります。
取扱説明書に従って正しい取り扱いをして下さい。

Power cord instructions

Make sure your power source is adequate for the product voltage rating. The voltage rating is on the product label. The product uses either 110-127 Vac or 220-240 Vac and 50/60 Hz.

Connect the power cord between the product and a grounded AC outlet.

CAUTION: To prevent damage to the product, use only the power cord that is provided with the product.

Power cord statement (Japan)

製品には、同梱された電源コードをお使い下さい。
同梱された電源コードは、他の製品では使用出来ません。

EMC statement (Korea)

B급 기기 (가정용 방송통신기기)	이 기기는 가정용(B급)으로 전자파적합등록을 한 기기로서 주로 가정에서 사용하는 것을 목적으로 하며, 모든 지역에서 사용할 수 있습니다.
-----------------------	--

Laser statement for Finland

Luokan 1 laserlaite

Klass 1 Laser Apparat

HP LaserJet Professional P1100, P1100w, laserkirjoitin on käyttäjän kannalta turvallinen luokan 1 laserlaite. Normaalisissa käytöissä kirjoittimen suojakotelointi estää lasersäteiden pääsyn laitteen ulkopuolelle. Laitteen turvallisuusluokka on määritetty standardin EN 60825-1 (1994) mukaisesti.

VAROITUS !

Laitteen käyttäminen muulla kuin käyttöohjeessa mainitulla tavalla saattaa altistaa käyttäjän turvallisuusluokan 1 ylittävälle näkymättömälle lasersäteilylle.

WARNING !

Om apparaten används på annat sätt än i bruksanvisning specificerats, kan användaren utsättas för osynlig laserstrålning, som överskrider gränsen för laserklass 1.

HUOLTO

HP LaserJet Professional P1100, P1100w - kirjoittimen sisällä ei ole käyttäjän huollettavissa olevia kohteita. Laitteen saa avata ja huoltaa ainoastaan sen huoltamiseen koulutettu henkilö. Tällaiseksi huoltotoimenpiteeksi ei katsota väriainekasetin vaihtamista, paperiradan puhdistusta tai muita käyttäjän käsikirjassa lueteltuja, käyttäjän tehtäväksi tarkoitettuja ylläpitotoimia, jotka voidaan suorittaa ilman erikoistyökaluja.

VARO !

Mikäli kirjoittimen suojakotelo avataan, olet alttiina näkymättömälle lasersäteilylle laitteen ollessa toiminnassa. Älä katso säteeseen.

WARNING !

Om laserprinterns skyddshölje öppnas då apparaten är i funktion, utsättas användaren för osynlig laserstrålning. Betrakta ej strålen. Tiedot laitteessa käytettävän laserdiodin säteilyominaisuuksista: Aallonpituus 775-795 nm Teho 5 m W Luokan 3B laser.

GS statement (Germany)

Das Gerät ist nicht für die Benutzung im unmittelbaren Gesichtsfeld am Bildschirmarbeitsplatz vorgesehen. Um störende Reflexionen am Bildschirmarbeitsplatz zu vermeiden, darf dieses Produkt nicht im unmittelbaren Gesichtsfeld platziert werden.

Substances Table (China)

有毒有害物质表

根据中国电子信息产品污染控制管理办法的要求而出台

部件名称	有毒有害物质和元素					
	铅 (Pb)	汞 (Hg)	镉 (Cd)	六价铬 (Cr(VI))	多溴联苯 (PBB)	多溴二苯醚 (PBDE)
打印引擎	X	0	X	0	0	0
控制面板	0	0	0	0	0	0
塑料外壳	0	0	0	0	0	0
格式化板组件	X	0	0	0	0	0
碳粉盒	X	0	0	0	0	0

3685

0：表示在此部件所用的所有同类材料中，所含的此有毒或有害物质均低于 SJ/T11363-2006 的限制要求。

X：表示在此部件所用的所有同类材料中，至少一种所含的此有毒或有害物质高于 SJ/T11363-2006 的限制要求。

注：引用的“环保使用期限”是根据在正常温度和湿度条件下操作使用产品而确定的。

Additional statements for wireless products

FCC compliance statement—United States

Exposure to radio frequency radiation

CAUTION: The radiated output power of this device is far below the FCC radio frequency exposure limits. Nevertheless, the device shall be used in such a manner that the potential for human contact during normal operation is minimized.

In order to avoid the possibility of exceeding the FCC radio frequency exposure limits, human proximity to the antenna shall not be less than 20 cm (8 in)) during normal operation.

This device complies with Part 15 of FCC Rules. Operation is subject to the following two conditions: (1) this device may not cause interference, and (2) this device must accept any interference, including interference that may cause undesired operation of the device.

CAUTION: Based on Section 15.21 of the FCC rules, changes of modifications to the operation of this product without the express approval by Hewlett-Packard Company may invalidate its authorized use.

Australia statement

This device incorporates a radio-transmitting (wireless) device. For protection against radio transmission exposure, it is recommended that this device be operated no less than 20 cm from the head, neck, or body.

Brazil ANATEL statement

Este equipamento opera em caráter secundário, isto é, não tem direito à proteção contra interferência prejudicial, mesmo de estações do mesmo tipo, e não pode causar interferência a sistemas operando em caráter primário.

Canadian statements

For Indoor Use. This digital apparatus does not exceed the Class B limits for radio noise emissions from digital apparatus as set out in the radio interference regulations of the Canadian Department of Communications. The internal wireless radio complies with RSS 210 of Industry Canada.

Pour l'usage d'intérieur. Le présent appareil numérique n'émet pas de bruits radioélectriques dépassant les limites applicables aux appareils numériques de Classe B prescrites dans le règlement sur le brouillage radioélectrique édicté par le Ministère des Communications du Canada. Le composant RF interne est conforme à la norme CNR-210 d'Industrie Canada.

European Union regulatory notice

The telecommunications functionality of this product may be used in the following EU and EFTA countries/regions:

Austria, Belgium, Bulgaria, Cyprus, Czech Republic, Denmark, Estonia, Finland, France, Germany, Greece, Hungary, Iceland, Ireland, Italy, Latvia, Liechtenstein, Lithuania, Luxembourg, Malta, Netherlands, Norway, Poland, Portugal, Romania, Slovak Republic, Slovenia, Spain, Sweden, Switzerland, and United Kingdom.

Notice for use in France

For 2.4 GHz Wireless LAN operation of this product certain restrictions apply: This equipment may be used indoor for the entire 2400-2483.5 MHz frequency band (channels 1-13). For outdoor use, only 2400-2454 MHz frequency band (channels 1-9) may be used. For the latest requirements, see www.arcep.fr.

L'utilisation de cet équipement (2.4 GHz Wireless LAN) est soumise à certaines restrictions : Cet équipement peut être utilisé à l'intérieur d'un bâtiment en utilisant toutes les fréquences de 2400-2483.5 MHz (Chaîne 1-13). Pour une utilisation en environnement extérieur, vous devez utiliser les fréquences comprises entre 2400-2454 MHz (Chaîne 1-9). Pour les dernières restrictions, voir, www.arcep.fr.

Notice for use in Russia

Существуют определенные ограничения по использованию беспроводных сетей (стандарта 802.11 b/g) с рабочей частотой 2,4 ГГц: Данное оборудование может использоваться внутри помещений с использованием диапазона частот 2400-2483,5 МГц (каналы 1-13). При использовании внутри помещений максимальная эффективная изотропно-излучаемая мощность (ЭИИМ) должна составлять не более 100мВт.

Korean statement

당해 무선설비는 운용 중 전파혼선 가능성이 있음

Taiwan statement

低功率電波輻射性電機管理辦法

第十二條 經型式認證合格之低功率射頻電機，非經許可，公司、商號或使用者均不得擅自變更頻率、加大功率或變更原設計之特性及功能。

第十四條 低功率射頻電機之使用不得影響飛航安全及干擾合法通信；經發現有干擾現象時，應立即停用，並改善至無干擾時方得繼續使用。前項合法通信，指依電信法規定作業之無線電通信。低功率射頻電機須忍受合法通信或工業、科學及醫療用電波輻射性電機設備之干擾。

Index

A

accessories
 ordering 136
acoustic specifications 168
after-service checklist 34
altitude specifications 169

B

bin, output
 jams, clearing 111
blank pages
 problem-solving 129

C

cables
 USB, problem-solving 129
Canadian DOC regulations 177
cartridge
 ordering xi
 part number xi
cartridges
 drum rotation check 94
 warranty 161
cautions iii
certificate of volatility 175
checklists
 after-service 34
 preservice 34
 problem source 91
checks
 drum rotation 94
 half self-test 94
clean
 pickup roller 123
cleaning
 exterior 128
 paper path 124
 product 117
clearing jams
 locations 108

configuration page 102
control panel
 status-light patterns 103
conventions, document iii
crooked pages 116
customer support
 online 105
 repacking product 165
 service information form 166

D

declaration of conformity 173, 174
Demo page 90
developing stage 25
document conventions iii
drum
 rotation functional check 94
drum cleaning stage 27

E

electrostatic discharge (ESD) 33
engine-control system 7
environment specifications 169
ESD (electrostatic discharge) 33

F

feeding problems, solving 116
Finnish laser safety
 statement 178
fusing stage 27

H

half self-test check 94
HP Customer Care 105
humidity specifications 169

I

image-formation system
 testing 94

improve print quality 117
information pages
 configuration page 102

J

jams
 common causes of 107
 locations 108
 output-bin, clearing 111
 preventing 114
 tray, clearing 109
Japanese VCCI statement 177

K

Korean EMC statement 177

L

laser beam exposure stage 24
laser safety statements 177, 178
laser/scanner
 operations 19
license, software 162
light patterns 103
location
 assemblies (base product) xi

M

Macintosh
 support 164

N

noise specifications 168
notes iii

O

online support 105
operating environment
 specifications 169

- operations
 - engine-control system 7
 - laser/scanner 19
- ordering
 - print cartridge xi
 - product documents xi
 - supplies and accessories 136
 - whole-unit replacement xi
- output quality. *See* print quality

P

- packaging product 165
- pages
 - blank 129
 - not printing 129
 - printing slowly 129
- pages, skewed 116
- paper handling
 - problem-solving 116
- paper input trays
 - feeding problems, solving 116
- paper jams. *See* jams
- paper path, cleaning 124
- part number
 - print cartridge xi
 - whole-unit replacement xi
- parts
 - assemblies (base product) xi
- photosensitive drum
 - rotation functional checks 94
- physical specifications 168
- pickup roller
 - clean 123
- pliers, required 33
- post-service tests 35
- power
 - troubleshooting 88
- preservice checklist 34
- primary charging stage 24
- print cartridge
 - ordering xi
 - part number xi
- print cartridges
 - warranty 161
- print density 118
- print quality
 - creases 120
 - curl 120
 - dropouts 118
 - gray background 118

- improve 117
- light or faded print 117
- loose toner 119
- misformed characters 119
- moisture on trailing edge 121
- page skew 119
- problem-solving 117
- steam or vapor from the
 - product 121
- test 35
- toner scatter outline 120
- toner smear 118
- toner specks 117
- vertical lines 118
- vertical repetitive defects 119
- wave 120
- wrinkles 120
- printing
 - configuration page 102
 - problem-solving 129
- problem-solving
 - blank pages 129
 - direct-connect problems 130
 - output quality 117
 - pages not printing 129
 - pages printing slowly 129
 - paper handling 116
 - status-light patterns 103
 - USB cables 129
 - wireless problems 90
- product
 - cleaning 117
- product information pages
 - configuration page 102

Q
quality. *See* print quality

R

- removing parts
 - cautions for 32
 - checklists 34
 - tools, required 33
- repacking product 165
- replacing
 - parts 32
- resolution
 - problem-solving quality 117
- rotation check, drum 94

S

- safety statements 177, 178
- screwdrivers, required 33
- screws
 - replacing 32
- separation stage 26
- service
 - information form 166
 - repacking product 165
 - tools, required 33
- shipping product 165
- size specifications, product 168
- skewed pages 116
- software
 - software license agreement 162
- solving
 - creases 120
 - curl 120
 - direct-connect problems 130
 - dropouts 118
 - feeding problems 116
 - gray background 118
 - light or faded print 117
 - loose toner 119
 - misformed characters 119
 - moisture on trailing edge 121
 - page skew 119
 - skewed pages 116
 - steam or vapor from the
 - product 121
 - toner scatter outline 120
 - toner smear 118
 - toner specks 117
 - vertical lines 118
 - vertical repetitive defects 119
 - wave 120
 - wireless problems 90
 - wrinkles 120
- specifications
 - acoustic 168
 - environment 169
 - physical 168
- static precautions 33
- status-light patterns 103
- storing
 - product 169
- supplies
 - ordering 136

- support
 - online 105
 - repacking product 165
 - service information form 166

- Web sites
 - customer support 105
 - Macintosh customer support 164

T

- technical support
 - online 105
 - repacking product 165
 - service information form 166
- temperature specifications 169
- tests
 - drum rotation 94
 - half self-test check 94
 - post-service 35
 - print-quality 35
- tips iii
- toner
 - loose toner 119
 - low 117
 - scatter outline 120
 - smear 118
 - specks 117
- toner cartridges. See print cartridges
- tools, required 33
- transfer stage 26
- tray
 - jams, clearing 109
- troubleshooting
 - basic steps 88
 - checklist 88
 - Demo page 90
 - drum rotation check 94
 - half self-test 94
 - image formation 94
 - power 88
 - problem source 91

U

- USB port
 - problem-solving 129

W

- warnings iii
- warranty
 - customer self repair 164
 - license 162
 - print cartridges 161
 - product 160

