

Basic User's Guide

DCP-8110DN
DCP-8150DN
DCP-8155DN

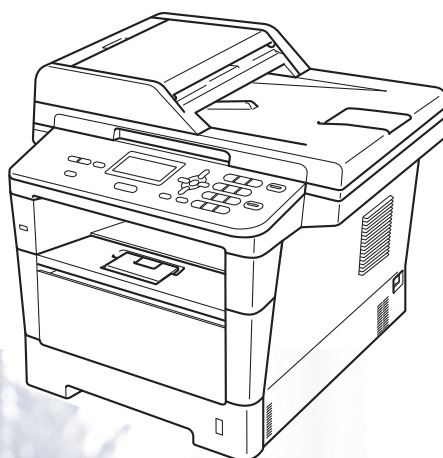

Not all models are available in all countries.

(in USA):

Please go to the Brother Solutions Center at <http://solutions.brother.com/> and click Manuals on your model page to download the other manuals.

If you need to call Customer Service

Please complete the following information for future reference:

**Model Number: DCP-8110DN / DCP-8150DN /
DCP-8155DN**
(Circle your model number)

Serial Number: ¹ _____

Date of Purchase: _____

Place of Purchase: _____

¹ The serial number is on the back of the unit. Retain this User's Guide with your sales receipt as a permanent record of your purchase, in the event of theft, fire or warranty service.

Register your product on-line at

<http://www.brother.com/registration/>

By registering your product with Brother, you will be recorded as the original owner of the product. Your registration with Brother:

- may serve as confirmation of the purchase date of your product should you lose your receipt;
- may support an insurance claim by you in the event of product loss covered by insurance; and,
- will help us notify you of enhancements to your product and special offers.

The most convenient and efficient way to register your new product is online at <http://www.brother.com/registration/>.

Brother numbers

Important

For technical help, you must call the country where you bought the machine. Calls must be made **from within** that country.

Register your product

By registering your product with Brother International Corporation, you will be recorded as the original owner of the product. Your registration with Brother:

- may serve as confirmation of the purchase date of your product should you lose your receipt;
- may support an insurance claim by you in the event of product loss covered by insurance; and,
- will help us notify you of enhancements to your product and special offers.

Please complete and fax the Brother Warranty Registration and Test Sheet or, for your convenience and most efficient way to register your new product, register on-line at

<http://www.brother.com/registration/>

FAQs (frequently asked questions)

The Brother Solutions Center is our one-stop resource for all your Fax Machine/Multi-Function Center needs. You can download the latest software and utilities and read FAQs and troubleshooting tips to learn how to get the most from your Brother product.

<http://solutions.brother.com/>

Note

You can check here for Brother driver updates.

To keep your machine's performance up to date, check here for the latest firmware upgrade.

For Customer Service

In USA: 1-877-BROTHER (1-877-276-8437)
1-901-379-1215 (fax)

In Canada: 1-877-BROTHER
(514) 685-4898 (fax)

Service Center Locator (USA only)

For the location of a Brother authorized service center, call 1-877-BROTHER (1-877-276-8437) or visit us on-line at <http://www.brother-usa.com/service/>.

Service Center Locations (Canada only)

For the location of a Brother authorized service center, call 1-877-BROTHER.

Ordering accessories and supplies

For best quality results use only genuine Brother accessories, which are available at most Brother retailers. If you cannot find the accessory you need and you have a Visa, MasterCard, Discover, or American Express credit card, you can order accessories directly from Brother. (You can visit us online for a complete selection of the Brother accessories and supplies that are available for purchase.)



Note

In Canada, only Visa and MasterCard are accepted.

In USA: 1-877-552-MALL (1-877-552-6255)
1-800-947-1445 (fax)

<http://www.brothermall.com/>

In Canada: 1-877-BROTHER

<http://www.brother.ca/>

Description	Item
Toner Cartridge <Black>	TN-720 (Approx. 3,000 pages) ^{1 2 3} TN-750 (Approx. 8,000 pages) ^{1 2 4}
Drum Unit	DR-720 (Approx. 30,000 pages) ^{5 6}
Basic User's Guide	LX9483001 (English for USA and Canada)
Quick Setup Guide	LX9487001 (English for USA and Canada)
Paper Tray 2 (DCP-8150DN and DCP-8155DN option)	LT-5400

¹ Letter or A4 size single-sided pages.

² Approx. cartridge yield is declared in accordance with ISO/IEC 19752.

³ Standard toner cartridge

⁴ High yield toner cartridge

⁵ 1 page per job.

⁶ Drum life is approximate and may vary by type of use.

Notice - Disclaimer of Warranties (USA and Canada)

BROTHER'S LICENSOR(S), AND THEIR DIRECTORS, OFFICERS, EMPLOYEES OR AGENTS (COLLECTIVELY BROTHER'S LICENSOR) MAKE NO WARRANTIES, EXPRESS OR IMPLIED, INCLUDING WITHOUT LIMITATION THE IMPLIED WARRANTIES OF MERCHANTABILITY AND FITNESS FOR A PARTICULAR PURPOSE, REGARDING THE SOFTWARE. BROTHER'S LICENSOR(S) DOES NOT WARRANT, GUARANTEE OR MAKE ANY REPRESENTATIONS REGARDING THE USE OR THE RESULTS OF THE USE OF THE SOFTWARE IN TERMS OF ITS CORRECTNESS, ACCURACY, RELIABILITY, CURRENTNESS OR OTHERWISE. THE ENTIRE RISK AS TO THE RESULTS AND PERFORMANCE OF THE SOFTWARE IS ASSUMED BY YOU. THE EXCLUSION OF IMPLIED WARRANTIES IS NOT PERMITTED BY SOME STATES IN THE USA AND SOME PROVINCES IN CANADA. THE ABOVE EXCLUSION MAY NOT APPLY TO YOU.

IN NO EVENT WILL BROTHER'S LICENSOR(S) BE LIABLE TO YOU FOR ANY CONSEQUENTIAL, INCIDENTAL OR INDIRECT DAMAGES (INCLUDING DAMAGES FOR LOSS OF BUSINESS PROFITS, BUSINESS INTERRUPTION, LOSS OF BUSINESS INFORMATION, AND THE LIKE) ARISING OUT OF THE USE OR INABILITY TO USE THE SOFTWARE EVEN IF BROTHER'S LICENSOR HAS BEEN ADVISED OF THE POSSIBILITY OF SUCH DAMAGES. BECAUSE SOME STATES IN THE USA AND SOME PROVINCES IN CANADA DO NOT ALLOW THE EXCLUSION OR LIMITATION OF LIABILITY FOR CONSEQUENTIAL OR INCIDENTAL DAMAGES, THE ABOVE LIMITATIONS MAY NOT APPLY TO YOU. IN ANY EVENT BROTHER'S LICENSOR'S LIABILITY TO YOU FOR ACTUAL DAMAGES FROM ANY CAUSE WHATSOEVER, AND REGARDLESS OF THE FORM OF THE ACTION (WHETHER IN CONTRACT, TORT (INCLUDING NEGLIGENCE), PRODUCT LIABILITY OR OTHERWISE), WILL BE LIMITED TO \$50.

Compilation and Publication Notice

Under the supervision of Brother Industries Ltd., this manual has been compiled and published, covering the latest product descriptions and specifications.

The contents of this manual and the specifications of this product are subject to change without notice.

Brother reserves the right to make changes without notice in the specifications and materials contained herein and shall not be responsible for any damages (including consequential) caused by reliance on the materials presented, including but not limited to typographical and other errors relating to the publication.

User's Guides and where do I find them?

Which Guide?	What's in it?	Where is it?
Product Safety Guide	Read this Guide first. Please read the Safety Instructions before you set up your machine. See this Guide for trademarks and legal limitations.	Printed / In the Box
Quick Setup Guide	Follow the instructions for setting up your machine and installing the drivers and software for the operating system and connection type you are using.	Printed / In the Box
Basic User's Guide	Learn the basic Copy, Scan and Direct Print operations and how to replace consumables. See troubleshooting tips.	Printed / In the Box
Advanced User's Guide	Learn more advanced operations: Copy, security features, printing reports and performing routine maintenance.	For USA: PDF file / Brother Solutions Center at http://solutions.brother.com/
Software User's Guide	Follow these instructions for Printing, Scanning, Network Scanning and using the Brother ControlCenter utility.	
Network User's Guide	This Guide provides useful information about wired network settings and security settings using the Brother machine. You can also find supported protocol information for your machine and detailed troubleshooting tips.	For Other Countries: PDF file / Installer CD-ROM / In the Box
Google Cloud Print Guide	This Guide provides details on how to configure your Brother machine to a Google account and use Google Cloud Print services for printing over the Internet from devices using Gmail™ for mobile, GOOGLE DOCS™ for mobile and applications for the Chrome OS.	PDF file / Brother Solutions Center ²
Mobile Print/Scan Guide for Brother iPrint&Scan	This Guide provides useful information about printing JPEG and PDF ¹ files from your mobile device and scanning from your Brother machine to your mobile device when connected on a Wi-Fi network.	PDF file / Brother Solutions Center ²

¹ PDF printing is not supported on Windows® Phone.

² Visit us at <http://solutions.brother.com/>.

Table of Contents

(Basic User's Guide)

1	General information	1
	Using the documentation.....	1
	Symbols and conventions used in the documentation	1
	Accessing the Advanced User's Guide, Software User's Guide and Network User's Guide	2
	Viewing Documentation	2
	How to access Guides for Advanced Features.....	4
	Accessing Brother Support (Windows®).....	4
	Accessing Brother Support (Macintosh).....	5
	Control panel overview	6
	Data LED indications	8
2	Loading paper	9
	Loading paper and print media.....	9
	Loading paper in the standard paper tray and the optional lower tray	9
	Loading paper in the multi-purpose tray (MP tray)	11
	Unscannable and unprintable areas.....	15
	Paper settings.....	16
	Paper Type	16
	Paper Size.....	16
	Tray Use in COPY mode	17
	Tray Use in print mode	17
	Acceptable paper and other print media.....	18
	Recommended paper and print media	18
	Type and size of paper	18
	Handling and using special paper	20
3	Loading documents	23
	How to load documents	23
	Using the automatic document feeder (ADF)	23
	Using the scanner glass	24
4	Making copies	25
	How to copy.....	25
	Stop copying.....	25
	Copy settings.....	25
5	Printing data from a USB Flash memory drive or digital camera supporting mass storage	26
	Creating a PRN file for direct printing	26
	Printing data directly from the USB Flash memory drive or digital camera supporting mass storage	27

6	How to print from a computer	30
	Printing a document.....	30
7	How to scan to a computer	31
	Scanning a document as a PDF file using ControlCenter4 (Windows®)	31
	Changing the SCAN key settings	34
	Before scanning.....	34
	SCAN key settings.....	34
	Scanning using the SCAN key	36
A	Routine maintenance	37
	Replacing the consumable items	37
	Replacing the toner cartridge	39
	Cleaning the corona wire	45
	Replacing the drum unit.....	47
B	Troubleshooting	52
	Identifying your problem	52
	Error and maintenance messages.....	53
	Document Jams	59
	Document is jammed in the top of the ADF unit	59
	Document is jammed under the document cover	59
	Removing small documents jammed in the ADF	60
	Document is jammed at the output tray	60
	Paper Jams.....	61
	Paper is jammed in the MP tray	61
	Paper is jammed in paper tray 1 or tray 2	62
	Paper is jammed at the back of the machine	63
	Paper is jammed inside the machine.....	66
	Paper is jammed in the duplex tray	70
	If you are having difficulty with your machine	72
	Improving the print quality.....	78
	Machine Information	86
	Checking the Serial Number.....	86
	Reset functions.....	86
	How to reset the machine	86
C	Menu and features	87
	On-screen programming.....	87
	How to access the menu mode	87
	Menu table	88
	Entering text.....	100

D Specifications 102

General	102
Document Size	104
Print media.....	105
Copy	106
Scanner	107
Printer	108
Direct Print feature.....	109
Computer requirements	110
Consumable items	112
Interfaces.....	113
Network (LAN)	114

E Index 115

Table of Contents

(Advanced User's Guide)

You can view the Advanced User's Guide on:

In USA: Brother Solutions Center at <http://solutions.brother.com/>

In Other Countries: Installer CD-ROM / In the Box

The Advanced User's Guide explains the following features and operations.

1 General Setup

IMPORTANT NOTE

Memory storage

Volume settings

Automatic Daylight Saving Time

Ecology features

Quiet mode feature

LCD Contrast

Glass ScanSize

User Settings List

Network Configuration Report

2 Security features

Secure Function Lock 2.0

Setting Lock

3 Making copies

Copy settings

Duplex (2-sided) copying

A Routine maintenance

Cleaning and checking the machine

Replacing periodic maintenance parts

Packing and shipping the machine

B Options

Options

Optional paper tray (LT-5400)

Memory board

C Glossary

D Index

Using the documentation

Thank you for buying a Brother machine! Reading the documentation will help you make the most of your machine.

Symbols and conventions used in the documentation

The following symbols and conventions are used throughout the documentation.

WARNING

WARNING indicates a potentially hazardous situation which, if not avoided, could result in death or serious injuries.

Important

Important indicates a potentially hazardous situation which, if not avoided, may result in damage to property or loss of product functionality.

 Prohibition icons indicate actions that must not be performed.

 Electrical Hazard icons alert you to a possible electrical shock.

 Fire Hazard icons alert you to the possibility of fire.

 Hot Surface icons warn you not to touch machine parts that are hot.

 Notes tell you how you should respond to a situation that may arise or give tips about how the current operation works with other features.

Bold Bold style identifies keys on the machine's control panel or on the computer screen.

Italics Italicized style emphasizes an important point or refers you to a related topic.

`Courier New` Courier New font identifies the messages shown on the LCD of the machine.

Follow all warnings and instructions marked on the product.



Note

Most of the illustrations in this User's Guide show the DCP-8155DN.

Accessing the Advanced User's Guide, Software User's Guide and Network User's Guide

This Basic User's Guide does not contain all the information about the machine such as how to use the advanced features for Copy, Printer, Scanner and Network. When you are ready to learn detailed information about these operations, read the **Advanced User's Guide**, **Software User's Guide** and **Network User's Guide**.

(In USA)

You can find these manuals on your model's page of the Brother Solutions Center at <http://solutions.brother.com/>.

Viewing Documentation

For USA:

Go to the Brother Solutions Center at <http://solutions.brother.com/> and click **Manuals** on your model's page to download the documentation.

For Other Countries:

Viewing Documentation (Windows®)

To view the documentation, from the **Start** menu, select **Brother, DCP-XXXX** (where XXXX is your model name) from the programs group, and then choose **User's Guides**.

If you have not installed the software, you can find the documentation on the Installer CD-ROM by following the instructions below:

- 1 Turn on your computer. Insert the Installer CD-ROM into your CD-ROM drive.



Note

If the Brother screen does not appear automatically, go to **My Computer (Computer)**, double-click the CD-ROM icon, and then double-click **start.exe**.

- 2 If the model name screen appears, click your model name.
- 3 If the language screen appears, click your language. The CD-ROM Top Menu will appear.

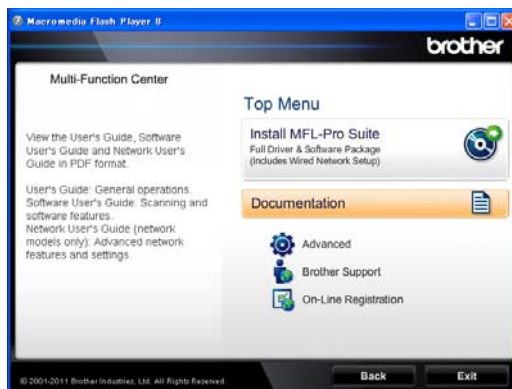

- 4 Click **Documentation**.
- 5 Click **PDF documents**. If the country screen appears, choose your country. After the list of User's Guides appears, choose the Guide you want to read.

Viewing Documentation (Macintosh)

- 1 Turn on your Macintosh. Insert the Installer CD-ROM into your CD-ROM drive. The following window will appear.



- 2 Double-click the **Documentation** icon.
- 3 If the model name screen appears, choose your model name and click **Next**.
- 4 If the language screen appears, double-click your language folder.
- 5 Double-click **top.pdf**. If the country screen appears, choose your country.
- 6 After the list of User's Guides appears, choose the Guide you want to read.

How to find Scanning instructions

There are several ways you can scan documents. You can find the instructions as follows:

Software User's Guide

- *Scanning*
- *ControlCenter*
- *Network Scanning*

Nuance™ PaperPort™ 12SE How-to-Guides

(Windows® users)

- The complete Nuance™ PaperPort™ 12SE How-to- Guides can be viewed from the Help selection in the Nuance™ PaperPort™ 12SE application.

Presto! PageManager User's Guide

(Macintosh users)



Note

Presto! PageManager is available as a download from http://nj.newsoft.com.tw/download/brother/PM9SEInstaller_BR_multilang.dmg

- The complete Presto! PageManager User's Guide can be viewed from the Help selection in the Presto! PageManager application.

How to find Network setup instructions

Your machine can be connected to a wired network.

Basic setup instructions >> Quick Setup Guide

More information about network setup

>> Network User's Guide ¹

¹ **In USA:** You can find the Network User's Guide on the Brother Solutions Center at <http://solutions.brother.com/>.

How to access Guides for Advanced Features

You can view and download these Guides from the Brother Solutions Center at:

<http://solutions.brother.com/>

Click **Manuals** on your model's page to download the documentation.

Google Cloud Print Guide

This Guide provides details on how to configure your Brother machine to a Google account and use Google Cloud Print services for printing over the Internet from devices using Gmail™ for mobile, GOOGLE DOCS™ for mobile and applications for the Chrome OS.

Mobile Print/Scan Guide for Brother iPrint&Scan

This Guide provides useful information about printing JPEG and PDF ¹ files from your mobile device and scanning from your Brother machine to your mobile device when connected on a Wi-Fi network.

¹ PDF printing is not supported on Windows® Phone.

Accessing Brother Support (Windows®)

You can find all the links you will need, such as Web support (Brother Solutions Center), Customer Service and Brother Authorized Service Centers in *Brother numbers* >> page i and the Installer CD-ROM.

- Click **Brother Support** on the main menu. The following screen will appear:



- To access our Web site (<http://www.brother.com/>) click **Brother Home Page**.
- To view all Brother Numbers, including Customer Service numbers for the USA and Canada, click **Support Information**.
- To access the USA Brother online shopping mall (<http://www.brothermall.com/>) for additional product and service information, click **Brother Mall.com**.
- To access Canada's Brother online shopping mall (<http://www.brother.ca/>) for additional product and services information, click **Shop Online (Canada)**.
- For the latest news and product support information (<http://solutions.brother.com/>), click **Brother Solutions Center**.
- To visit our web site for original/genuine Brother supplies (<http://www.brother.com/original/>), click **Supplies Information**.

- To access the Brother CreativeCenter (<http://www.brother.com/creativecenter/>) for FREE photo projects and printable downloads, click **Brother CreativeCenter**.

To return to the main page, click **Back**.

Or, if you have finished, click **Exit**.

Accessing Brother Support (Macintosh)

You can find all the links you will need, such as Web support (Brother Solutions Center) on the Installer CD-ROM.

- Double-click the **Brother Support** icon. The following screen will appear:

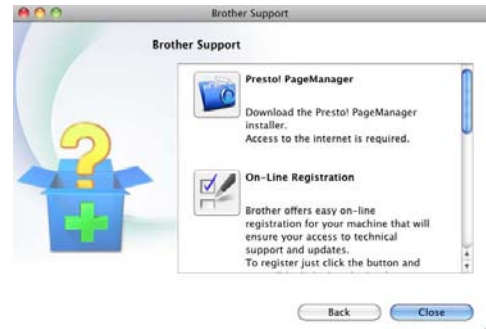

- To download and install Presto! PageManager, click **Presto! PageManager**.
- To register your machine using the Brother Product Registration Page (<http://www.brother.com/registration/>), click **On-Line Registration**.
- For the latest news and product support information (<http://solutions.brother.com/>), click **Brother Solutions Center**.
- To visit our Web site for original/genuine Brother Supplies (<http://www.brother.com/original/>), click **Supplies Information**.

Control panel overview

DCP-8110DN, DCP-8150DN and DCP-8155DN have the same keys. The illustration is based on the DCP-8155DN.

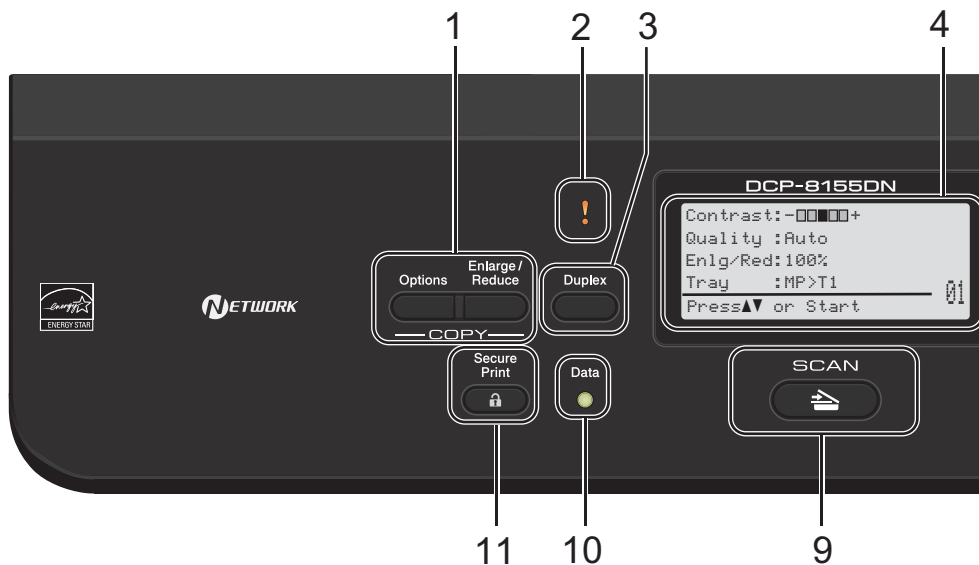

1 COPY keys:

Options

You can quickly and easily choose temporary settings for copying.

Enlarge/Reduce

Enlarges or reduces copies.

2 Error LED

Blinks in orange when the LCD displays an error or an important status message.

3 Duplex

You can choose Duplex to copy or print on both sides of the paper.

4 LCD

Displays messages to help you set up and use your machine.

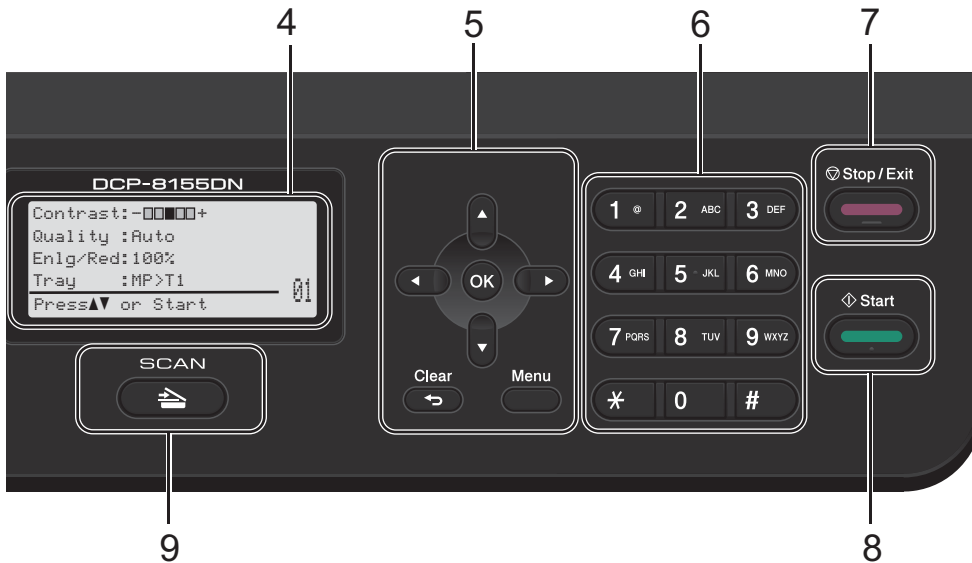

5 Menu keys:

Clear

Deletes entered data or lets you cancel the current setting.

Menu

Lets you access the Menu to program your settings in the machine.

OK

Lets you store your settings in the machine.

Selection keys:

◀ or ▶

Press to scroll backwards or forwards through menu selections.

▲ or ▼

Press to scroll through the menus and options.

6 Numeric keys

Use these keys to enter text.

7 Stop/Exit

Stops an operation or exits from a menu.

8 Start

Lets you start making copies.

9 SCAN:



SCAN

Puts the machine in SCAN mode.

10 Data LED

The LED will flash depending on the machine's status.

11 Secure Print



You can print data saved in the memory when you enter your four-digit password. (See Software User's Guide.)

When using Secure Function Lock, you can switch restricted users by holding down ◀ as you press **Secure Print**. (See Advanced User's Guide: *Secure Function Lock 2.0.*)

Data LED indications

The **Data** LED (light emitting diode) will flash depending on the machine's status.



LED	Machine Status	Description
	Ready Mode	The machine is ready to print, in Sleep mode, there is no print data, or the power switch is off.
 Green (blinking)	Receiving Data	The machine is either receiving data from the computer, processing data in memory, or printing data.
 Green	Data Remaining in Memory	Print data remains in the machine's memory.

2

Loading paper

Loading paper and print media

The machine can feed paper from the standard paper tray, optional lower tray ¹ or multi-purpose tray.

When you put paper into the paper tray, note the following:

- If your application software supports paper size selection in the print menu, you can select it through the software. If your application software does not support it, you can set the paper size in the printer driver or by using the control panel buttons.

¹ The optional lower tray is available for DCP-8150DN and DCP-8155DN.

Loading paper in the standard paper tray and the optional lower tray

You can load up to 250 sheets in the standard paper tray (Tray 1) and 500 sheets in the optional lower tray (Tray 2). Paper can be loaded up to the maximum paper mark (▼▼▼) on the right-hand side of the paper tray. (For recommended paper to use, see *Acceptable paper and other print media* >> page 18.)

Printing on plain paper, thin paper or recycled paper from Tray 1 and Tray 2

- 1 Pull the paper tray completely out of the machine.

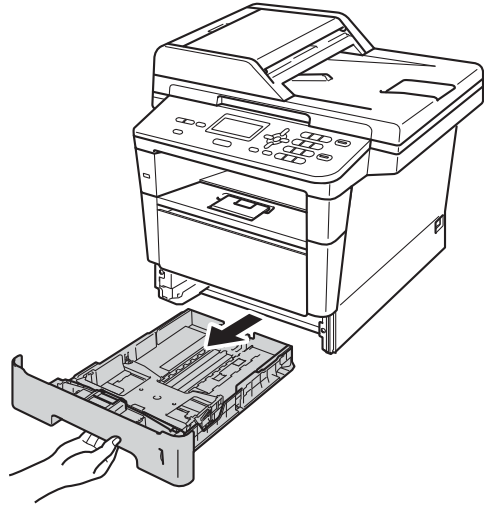

- 2 While pressing the green paper-guide release lever (1), slide the paper guides to fit the paper you are loading in the tray. Make sure that the guides are firmly in the slots.

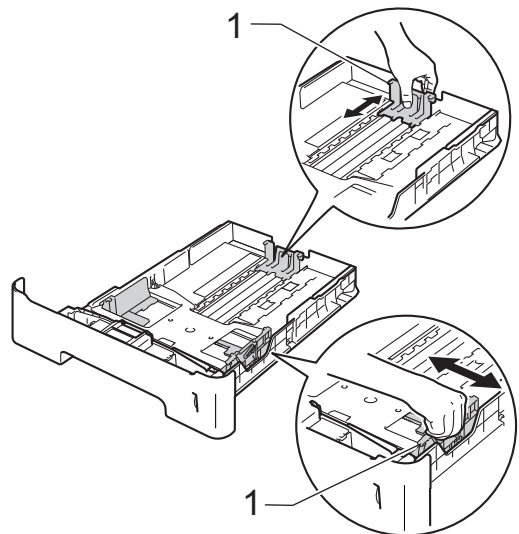

 **Note**

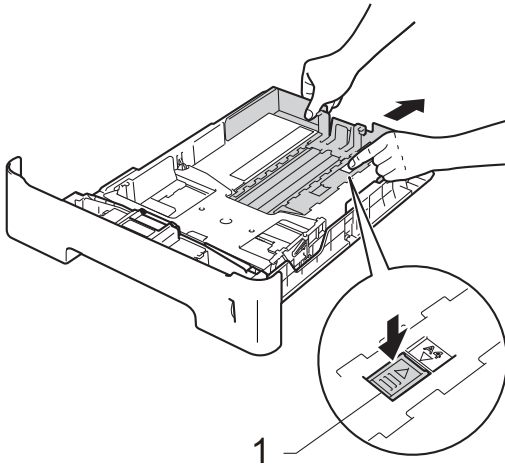

For Legal or Folio size paper, press the release button (1) in the bottom of the paper tray and then pull out the back of the paper tray. (Legal and Folio size paper are not available in some regions.)

- 3 Fan the stack of paper well to avoid paper jams and misfeeds.

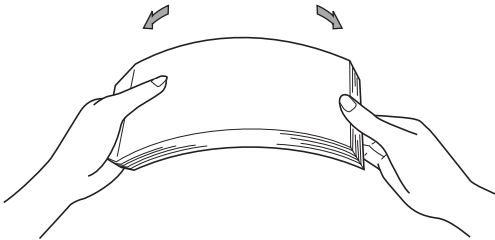

- 4 Put paper in the tray and make sure:

- The paper is below the maximum paper mark (▼▼▼) (1).
- The side to be printed on must be *face down*.
- The paper guides touch the sides of the paper so it will feed correctly.

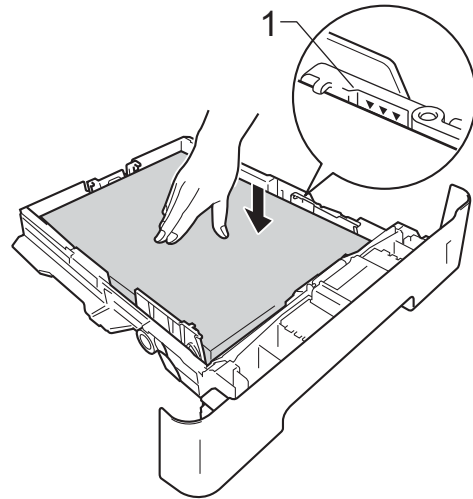

- 5 Put the paper tray firmly back in the machine. Make sure that it is completely inserted into the machine.

- 6 Lift up the support flap (1) to prevent paper from sliding off the face-down output tray, or remove each page as soon as it comes out of the machine.

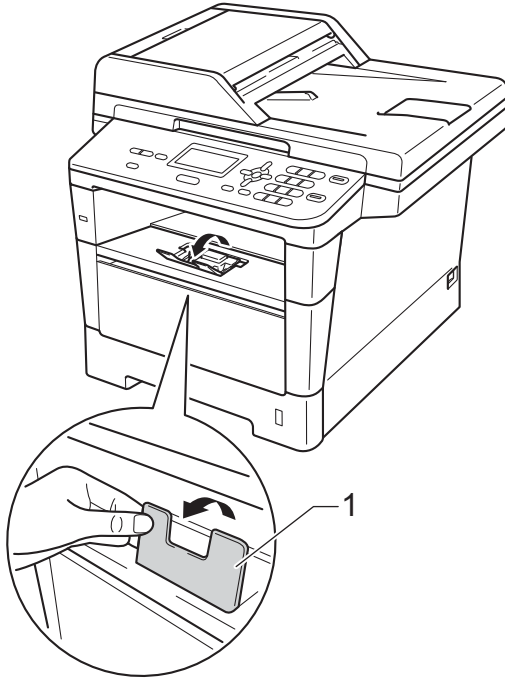

Loading paper in the multi-purpose tray (MP tray)

You can load up to 3 envelopes or special print media in the MP tray or up to 50 sheets of plain paper. Use this tray to print or copy on thick paper, bond paper, labels or envelopes. (For recommended paper to use, see *Paper capacity of the paper trays* >> page 19.)

Printing on plain paper, thin paper, recycled paper and bond paper from the MP tray

- 1 Open the MP tray and lower it gently.

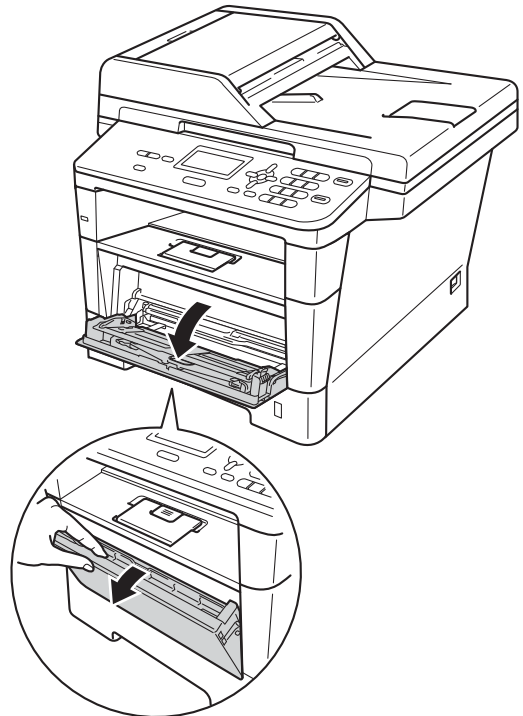

- 2 Pull out the MP tray support (1) and unfold the flap (2).

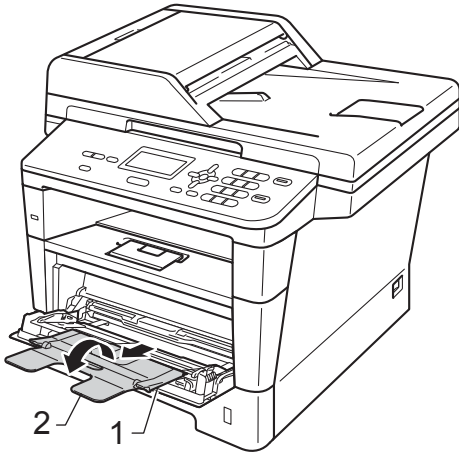

- 3 Put paper in the MP tray and make sure:
- The paper stays under the maximum paper mark (1).
 - The side to be printed on must be *face up* with the leading edge (top of the paper) in first.
 - The paper guides touch the sides of the paper so it will feed correctly.

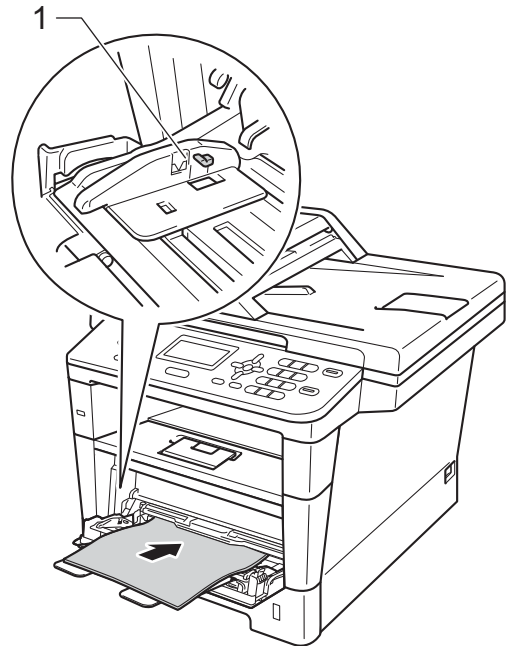

- 4 Lift up the support flap to prevent paper from sliding off the face-down output tray, or remove each page as soon as it comes out of the machine.

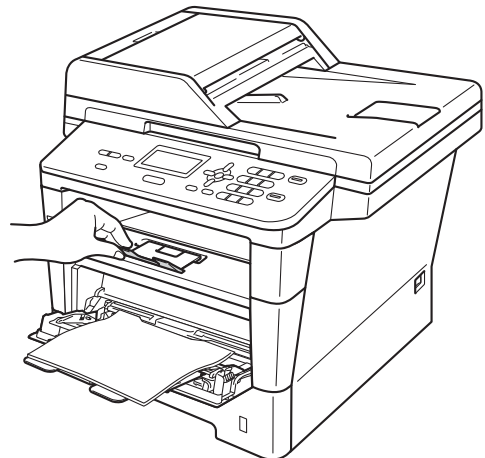

Printing on thick paper, labels and envelopes from the MP tray

Before loading, press the corners and sides of the envelopes to make them as flat as possible.

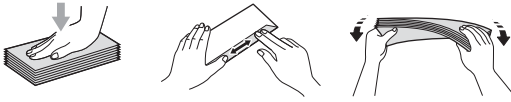

- 1 Open the back cover (face-up output tray).

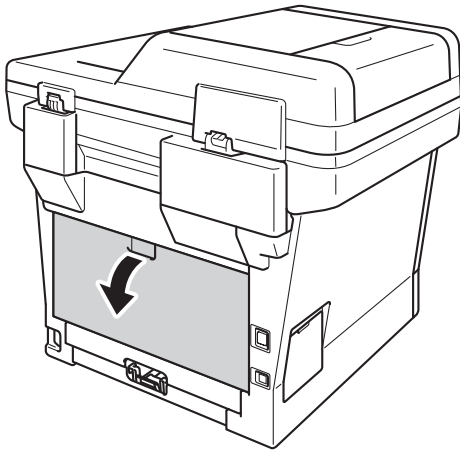

- 2 Open the MP tray and lower it gently.

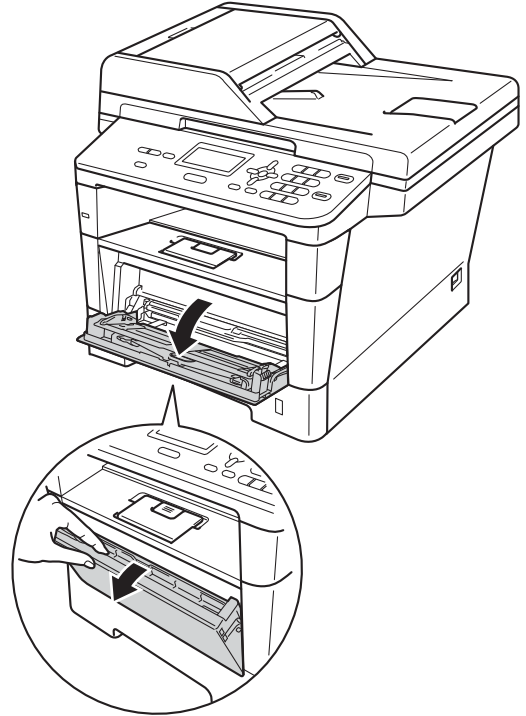

- 3 Pull out the MP tray support (1) and unfold the flap (2).

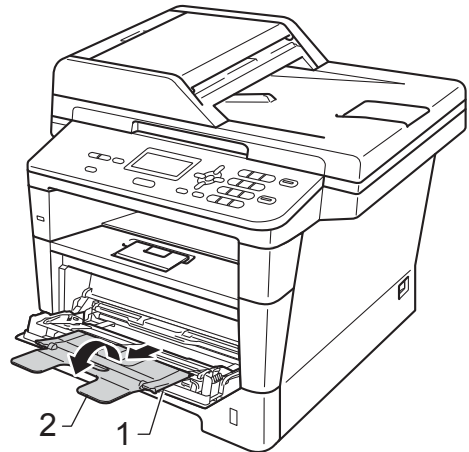

- 4 Put paper, labels or envelopes in the MP tray. Make sure:
 - The number of envelopes in the MP tray does not exceed 3.
 - The paper, labels or envelopes stay under the maximum paper mark (1).
 - The side to be printed on must be face up.

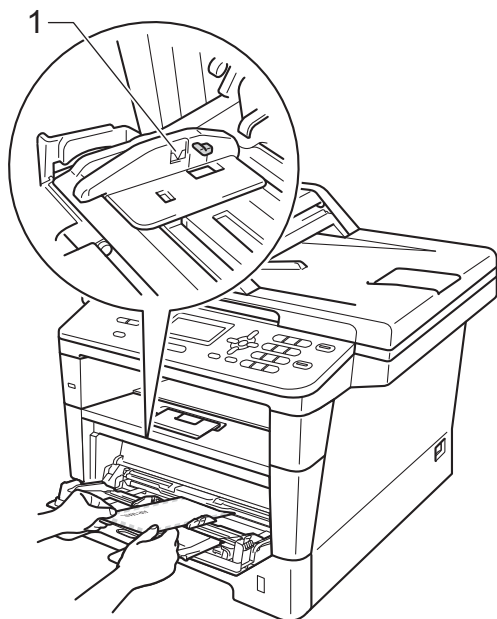

- 5 Send the print data to the machine.



Note

- Remove each printed envelope immediately to prevent a paper jam.
- If your thick paper curls during printing, put only one sheet at a time in the MP tray and open the back cover (face-up output tray) to let the printed pages exit to the face-up output tray.

- 6 Close the back cover (face-up output tray).

Unscannable and unprintable areas

The figures below show maximum unscannable and unprintable areas. These areas may vary depending on the paper size or settings in the application you are using.



Note

When using BR-Script3 emulation, the unprintable area around the edges of the paper is 0.16 in. (4.2 mm).

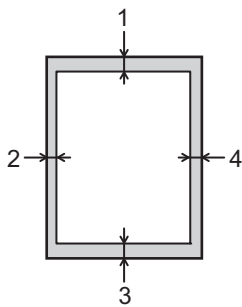

Usage	Document Size	Top (1) Bottom (3)	Left (2) Right (4)
Copy* * a single copy or a 1 in 1 copy	Letter	0.16 in. (4 mm)	0.16 in. (4 mm)
	A4	0.16 in. (4 mm)	0.12 in. (3 mm)
	Legal	0.16 in. (4 mm)	0.16 in. (4 mm)
Scan	Letter	0.12 in. (3 mm)	0.12 in. (3 mm)
	A4	0.12 in. (3 mm)	0.12 in. (3 mm)
	Legal	0.12 in. (3 mm)	0.12 in. (3 mm)
Print	Letter	0.16 in. (4.2 mm)	0.25 in. (6.35 mm)
	A4	0.16 in. (4.2 mm)	0.24 in. (6.01 mm)
	Legal	0.16 in. (4.2 mm)	0.25 in. (6.35 mm)

Paper settings

Paper Type

Set up the machine for the type of paper you are using. This will give you the best print quality.

- 1 Do one of the following:
 - To set the paper type for the MP Tray press **Menu, 1, 1, 1, 1**.
 - To set the paper type for Tray#1 press **Menu, 1, 1, 1, 2**.
 - To set the paper type for Tray#2¹ press **Menu, 1, 1, 1, 3**.

```

11.Paper Type
  1.MP Tray
  ▲ Plain
  ▼ Thick
  Select ▲▼ or OK
  
```

- 2 Press **▲** or **▼** to choose Thin, Plain, Thick, Thicker, Recycled Paper or Label². Press **OK**.

- 3 Press **Stop/Exit**.

- ¹ Tray#2 appears only if the optional lower tray is installed on the DCP-8150DN or DCP-8155DN.
- ² The Label type option appears only if you chose the MP tray in step 1.

Paper Size

You can use ten sizes of paper for copies: Letter, A4, Legal, Executive, A5, A5 L, A6, B5, B6 and Folio (8.5 in. × 13 in.).

When you change the size of paper in the tray, you will also need to change the Paper Size setting so your machine can fit the document on the page.

- 1 Do one of the following:
 - To set the paper size for the MP Tray press **Menu, 1, 1, 2, 1**.
 - To set the paper size for Tray#1 press **Menu, 1, 1, 2, 2**.
 - To set the paper size for Tray#2¹ press **Menu, 1, 1, 2, 3**.

```

12.Paper Size
  1.MP Tray
  ▲ Letter
  ▼ Legal
  Select ▲▼ or OK
  
```

- 2 Press **▲** or **▼** to choose A4, Letter, Legal, Executive, A5, A5 L, A6, B5, B6, Folio or Any². Press **OK**.

- 3 Press **Stop/Exit**.

- ¹ Tray#2 appears only if the optional lower tray is installed on the DCP-8150DN or DCP-8155DN.
- ² The Any option appears only when you choose the MP tray.



Note

- If you choose Any for the MP Tray Paper Size, you must choose MP Only for the Tray Use setting. You cannot use the Any Paper Size option for the MP tray when making N in 1 copies. You must choose one of the other available Paper Size options for the MP tray.
- A5 L and A6 size are not available for Tray#2.

Tray Use in COPY mode

You can change the priority tray that the machine will use for printing copies.

When you choose Tray#1 Only, MP Only or Tray#2 Only¹, the machine pulls the paper only from that tray. If the selected tray is out of paper, No Paper will appear on the LCD. Insert the paper in the empty tray.

To change the tray setting follow the instructions below:

- 1 Press **Menu, 1, 5, 1.**

```

15.Tray Use
 1.Copy
▲   MP>T1>T2
▼   T1>T2>MP
Select ▲▼ or OK
  
```

- 2 Press **▲** or **▼** to choose Tray#1 Only, Tray#2 Only¹, MP Only, MP>T1>T2¹ or T1>T2¹>MP. Press **OK**.

¹ Tray#2 Only and T2 appear only if the optional lower tray is installed on the DCP-8150DN or DCP-8155DN.

- 3 Press **Stop/Exit**.



Note

- When loading the documents in the ADF and MP>T1>T2 or T1>T2>MP is selected, the machine looks for the tray with the most suitable paper and pulls paper from that tray. If no tray has suitable paper, the machine pulls paper from the higher priority tray.
- When using the scanner glass, your document is copied from the higher priority tray even if more suitable paper is in another paper tray.

Tray Use in print mode

You can change the default tray the machine will use for printing from your computer and Direct Print.

- 1 Press **Menu, 1, 5, 2.**

```

15.Tray Use
 2.Print
▲   MP>T1>T2
▼   T1>T2>MP
Select ▲▼ or OK
  
```

- 2 Press **▲** or **▼** to choose Tray#1 Only, Tray#2 Only¹, MP Only, MP>T1>T2¹ or T1>T2¹>MP. Press **OK**.

¹ Tray#2 Only and T2 appear only if the optional lower tray is installed on the DCP-8150DN or DCP-8155DN.

- 3 Press **Stop/Exit**.

Acceptable paper and other print media

Print quality may vary according to the type of paper you are using.

You can use the following types of print media: plain paper, thin paper, thick paper, thicker paper, bond paper, recycled paper, labels or envelopes.

For best results, follow the instructions below:

- DO NOT put different types of paper in the paper tray at the same time because it may cause paper jams or misfeeds.
- For proper printing, you must choose the same paper size from your software application as the paper in the tray.
- Avoid touching the printed surface of the paper immediately after printing.
- Before you buy a lot of paper, test a small quantity to make sure the paper is suitable.
- Use labels that are designed for use in laser machines.

Recommended paper and print media

Paper Type	Item
Plain Paper	Xerox 4200DP 20 lb
	Hammermill Laser Print (24 lb=90 g/m ²)
Recycled Paper	No specific brand recommended
Labels	Avery laser labels white #5160
Envelopes	No specific brand recommended

Type and size of paper

The machine feeds paper from the installed standard paper tray, multi-purpose tray or optional lower tray.

The names for the paper trays in the printer driver and this Guide are as follows:

Tray and optional unit	Name
Standard Paper Tray	Tray 1
Multi-purpose Tray	MP Tray
Optional Lower Tray	Tray 2 ¹

¹ The optional lower tray is available for DCP-8150DN and DCP-8155DN.

Paper capacity of the paper trays

	Paper size	Paper types	No. of sheets
Standard Paper Tray (Tray 1)	Letter, A4, Legal, B5, Executive, A5, A5 (Long Edge), A6, B6, Folio ¹	Plain paper, Thin paper, Recycled paper	up to 250 20 lb (80 g/m ²)
Multi-purpose Tray (MP Tray)	Width: 3 to 8.5 in. (76.2 to 215.9 mm) Length: 5 to 14 in. (127.0 to 355.6 mm)	Plain paper, Thin paper, Thick paper, Thicker paper, Bond paper, Recycled paper, Envelopes, Labels	50 sheets 20 lb (80 g/m ²) 3 Envelopes
Optional Lower Tray (Tray 2) ²	Letter, A4, Legal, B5, Executive, A5, B6, Folio ¹	Plain paper, Thin paper, Recycled paper	up to 500 20 lb (80 g/m ²)

¹ Folio size is 8.5 in. × 13 in.

² The optional lower tray is available for DCP-8150DN and DCP-8155DN.

Recommended paper specifications

The following paper specifications are suitable for this machine.

Basis weight	20-24 lb (75-90 g/m ²)
Thickness	80-110 μm
Roughness	Higher than 20 sec.
Stiffness	90-150 cm ³ /100
Grain direction	Long grain
Volume resistivity	10e ⁹ -10e ¹¹ ohm
Surface resistivity	10e ⁹ -10e ¹² ohm-cm
Filler	CaCO ₃ (Neutral)
Ash content	Below 23 wt%
Brightness	Higher than 80%
Opacity	Higher than 85%

- Use paper made for plain paper copying.
- Use paper that is 20 to 24 lb (75 to 90 g/m²).
- Use long grain paper with a neutral Ph value, and a moisture content of approx. 5%.
- This machine can use recycled paper that meets DIN 19309 specifications.

Handling and using special paper

The machine is designed to work well with most types of xerographic and bond paper. However, some paper variables may have an effect on print quality or handling reliability. Always test samples of paper before purchasing to ensure desirable performance. Store paper in its original packaging and keep it sealed. Keep the paper flat and away from moisture, direct sunlight and heat.

Some important guidelines when selecting paper are:

- DO NOT use inkjet paper because it may cause a paper jam or damage your machine.
- Preprinted paper must use ink that can withstand the temperature of the machine's fusing process 392 °F (200 °C).
- If you use bond paper, paper with a rough surface, or paper that is wrinkled or creased, the paper may exhibit degraded performance.

Types of paper to avoid

! Important

Some types of paper may not perform well or may cause damage to your machine.

DO NOT use paper:

- that is highly textured
- that is extremely smooth or shiny
- that is curled or warped

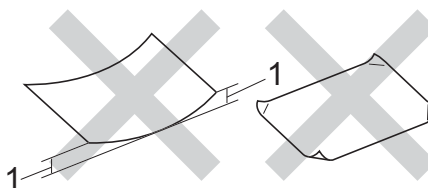

1 A curl of 0.08 in. (2 mm) or greater may cause jams to occur.

- that is coated or has a chemical finish
- that is damaged, creased or folded
- that exceeds the recommended weight specification in this guide
- with tabs and staples
- with letterheads using low temperature dyes or thermography
- that is multipart or carbonless
- that is designed for inkjet printing

If you use any of the types of paper listed above, they may damage your machine. This damage is not covered under any Brother warranty or service agreement.

Envelopes

Most envelopes designed for laser printers will be suitable for your machine. However, some envelopes may have feed and print-quality problems because of the way they have been made. A suitable envelope should have edges with straight, well-creased folds. The envelope should lie flat and not be of baggy or flimsy construction. You should buy quality envelopes from a supplier who understands that you will be using the envelopes in a laser machine.

Envelopes can only be fed through the MP tray.

We recommend that you print a test envelope to make sure the print results are what you want before printing a large amount of envelopes.

Types of envelopes to avoid

! Important

DO NOT use envelopes:

- that are damaged, curled, wrinkled or an unusual shape
- that are extremely shiny or textured
- with clasps, staples, snaps or tie strings
- with self-adhesive closures
- that are of a baggy construction
- that are not sharply creased
- that are embossed (have raised writing on them)
- that were previously printed by a laser machine
- that are pre-printed on the inside
- that cannot be arranged neatly when stacked
- that are made of paper that weighs more than the paper weight specifications for the machine
- with edges that are not straight or consistently square

- with windows, holes, cut-outs or perforations
- with glue on the surface as shown in the figure below

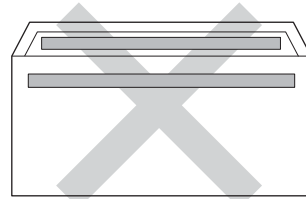

- with double flaps as shown in the figure below

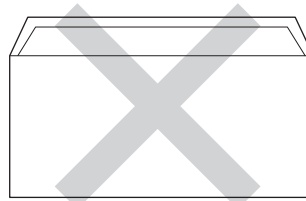

- with sealing flaps that are not folded down when purchased
- with each side folded as shown in the figure below

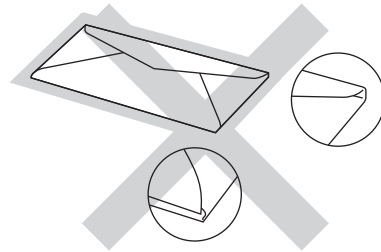

If you use any of the types of envelopes listed above, they may damage your machine. This damage may not be covered under any Brother warranty or service agreement.

Occasionally you may experience paper feed problems caused by the thickness, size and flap shape of the envelopes you are using.

Labels

The machine will print on most types of labels designed for use with a *laser* machine. Labels should have an adhesive that is acrylic-based since this material is more stable at the high temperatures in the fuser unit. Adhesives should not come in contact with any part of the machine. If this happens, the label stock may stick to the drum unit or rollers and cause jams and print quality problems. No adhesive should be exposed between the labels. Labels should be arranged so that they cover the entire length and width of the sheet. Using labels with spaces may result in labels peeling off and causing serious jams or print problems.

All labels used in this machine must be able to withstand a temperature of 392 °F (200 °C) for a period of 0.1 seconds.

Labels can only be fed through the MP tray.

Types of labels to avoid

Do not use labels that are damaged, curled, wrinkled or an unusual shape.

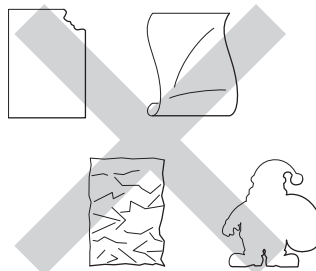

! Important

- Avoid feeding labels with the carrier sheet exposed because your machine will be damaged. DO NOT feed partially used carrier sheets.
- Label sheets should not exceed the paper weight specifications described in this User's Guide. Labels exceeding this specification may not feed or print correctly and may cause damage to your machine.
- DO NOT reuse or insert labels that have previously been used or are missing a few labels on the sheet.

How to load documents

You can copy and scan from the ADF (automatic document feeder) or the scanner glass.

Using the automatic document feeder (ADF)

The ADF can hold up to 35 pages (for DCP-8110DN) or up to 50 pages (for DCP-8150DN and DCP-8155DN) and feeds each sheet individually. Use standard 20 lb (80 g/m²) paper and always fan the pages before putting them in the ADF.

Document Sizes Supported

Length:	5.8 to 14 in. (147.3 to 355.6 mm)
Width:	5.8 to 8.5 in. (147.3 to 215.9 mm)
Weight:	17 to 24 lb (64 to 90 g/m ²)

How to load documents

! Important

- DO NOT leave thick documents on the scanner glass. If you do this, the ADF may jam.
- DO NOT use paper that is curled, wrinkled, folded, ripped, stapled, paper-clipped, pasted or taped.
- DO NOT use cardboard, newspaper or fabric.
- To avoid damaging your machine while using the ADF, DO NOT pull on the document while it is feeding.



Note

- To scan documents that are not suitable for the ADF, see *Using the scanner glass* >> page 24.
- It is easier to use the ADF if you are loading a multiple page document.
- Make sure documents with correction fluid or written with ink are completely dry.

- 1 Unfold the ADF document support (1). Lift up and unfold the ADF document output support flap (2).

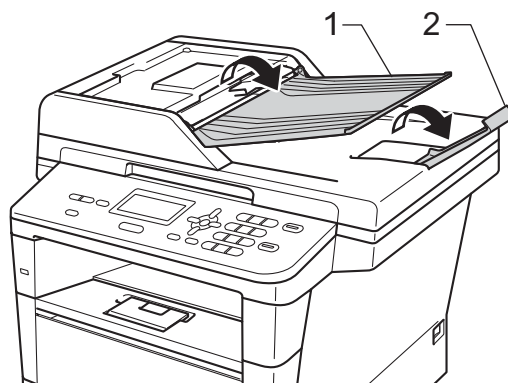

- 2 Fan the pages well.
- 3 Stagger the pages of your document *face up top edge first*, in the ADF until the LCD display message changes and you feel the top page touch the feed rollers.

- 4 Adjust the paper guides (1) to fit the width of your document.

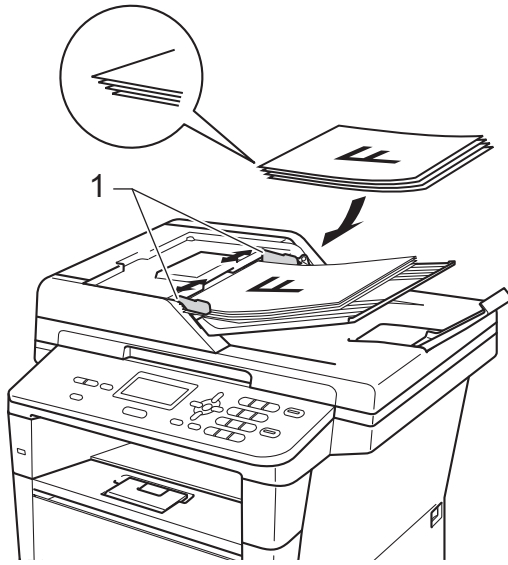

Note

To scan non-standard documents, see *Using the scanner glass* >> page 24.

Using the scanner glass

You can use the scanner glass to copy or scan pages of a book, one page at a time.

Document Sizes Supported

Length:	(DCP-8150DN and DCP-8155DN) Up to 14 in. (355.6 mm)
	(DCP-8110DN) Up to 11.8 in. (300.0 mm)
Width:	Up to 8.5 in. (215.9 mm)
Weight:	Up to 4.4 lb (2.0 kg)

How to load documents

Note

To use the scanner glass, the ADF must be empty.

- 1 Lift the document cover.
- 2 Using the document guidelines on the left and top, place the document *face down* in the upper left corner of the scanner glass.

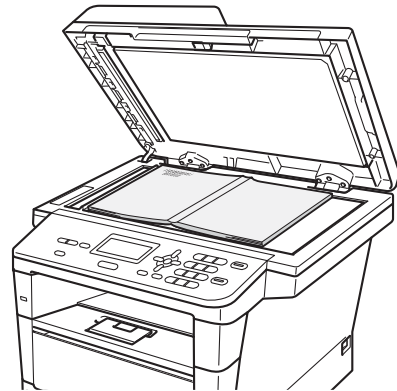
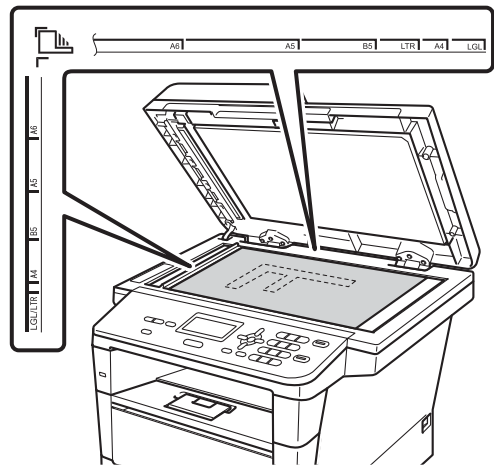

- 3 Close the document cover.

Important

If the document is a book or is thick do not slam the cover or press on it.

4

Making copies

How to copy

The following steps show the basic copy operation.

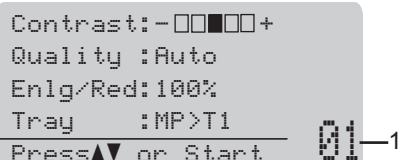

1 No. of Copies

Use the numeric pad to enter the number of copies you want.

- 1 Do one of the following to load your document:
 - Place the document *face up* in the ADF. (See *Using the automatic document feeder (ADF)* >> page 23.)
 - Load your document *face down* on the scanner glass. (See *Using the scanner glass* >> page 24.)

- 2 Press **Start**.

Stop copying

To stop copying, press **Stop/Exit**.

Copy settings

Press temporary **COPY** keys or **Duplex** and then press ▲, ▼, ◀ or ▶ to scroll through the copy settings. When the setting you want is highlighted, press **OK**.

(BASIC USER'S GUIDE)

For details about changing the following settings >> page 16 - 17:

- Paper Type
- Paper Size
- Tray Use (Tray Use in COPY mode)

(ADVANCED USER'S GUIDE)

For details about changing the following settings >> Advanced User's Guide: *Copy settings*:

- Enlg/Red (Enlarge/Reduce)
- Stack/Sort
- Quality
- Brightness
- Contrast
- Page Layout
- Tray Select (Tray Selection)
- Duplex

5

Printing data from a USB Flash memory drive or digital camera supporting mass storage

With the Direct Print feature, you do not need a computer to print data. You can print by just plugging your USB Flash memory drive into the machine's USB direct interface. You can also connect and print directly from a camera set to USB mass storage mode.

You can use a USB Flash Memory Drive that has the following specifications:

USB Class	USB Mass Storage Class
USB Mass Storage Class	SCSI or SFF-8070i
Transfer protocol	Bulk transfer Only
Format ¹	FAT12/FAT16/FAT32
Sector size	Max. 4096Byte
Encryption	Encrypted devices are not supported.

¹ NTFS format is not supported.



Note

- Some USB Flash memory drives may not work with the machine.
- If your camera is in PictBridge mode, you cannot print data. Please refer to the documentation supplied with your camera to switch from PictBridge mode to mass storage mode.

Creating a PRN file for direct printing



Note

The screens in this section may vary depending on your application and operating system.

- 1 From the menu bar of an application, click **File**, then **Print**.

- 2 Choose **Brother DCP-XXXX Printer** (1) and check the **Print to file** box (2). Click **Print**.

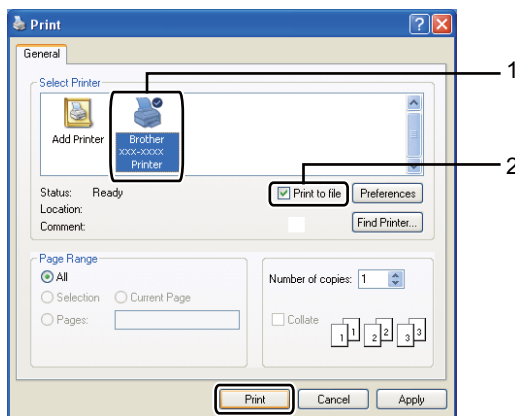

- 3 Choose the folder you want to save the file to and enter the file name if you are prompted to.

If you are prompted for a file name only, you can also specify the folder you want to save the file in by entering the directory name. For example:

C:\Temp\FileName.prn

If you have a USB Flash memory drive or digital camera connected to your computer, you can save the file directly to the USB Flash memory drive.

Printing data directly from the USB Flash memory drive or digital camera supporting mass storage

- 1 Connect your USB Flash memory drive or digital camera to the USB direct interface (1) on the front of the machine. Your machine will enter Direct Print mode automatically. The LCD will automatically show the USB memory menu to confirm the intended use of the USB Flash memory drive or digital camera.

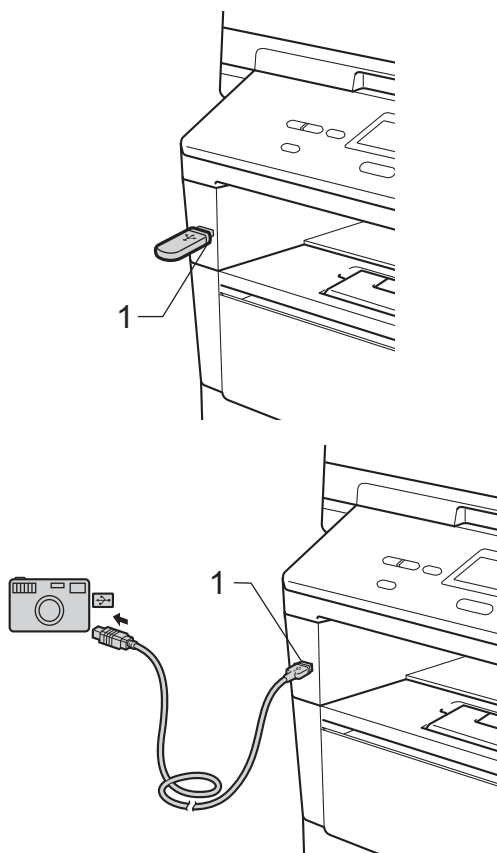

Note

- Make sure your digital camera is turned on.
- If an error occurs, the USB memory options `Direct Print` and `Scan to USB` will not appear on the LCD.
- When the machine is in the Deep Sleep mode, the LCD does not show any information even if you connect a USB Flash memory drive or digital camera to the USB direct interface. Press **Stop/Exit** on the control panel to wake up the machine.

- 2 Press **▲** or **▼** to choose 1. `Direct Print`. Press **OK**.

Note

- If `Direct Print` is restricted in `Secure Function Lock 2.0` for your User ID, and access has been given to another User ID or Public mode, `Access Denied` will appear on the LCD. Then the LCD will show `Change ID` and other User IDs so you may switch to a User ID or Public mode that has access.

If you are a restricted user with access to `Direct Print`, press **▲** or **▼** to choose your name and press **OK**. Enter your four-digit password and press **OK**.

- If your machine has been set to `Secure Function Lock On`, you may not be able to access `Direct Print`. (See *Advanced User's Guide: Switching Users.*)
- If your ID has been restricted to a page limit in `Secure Function Lock`, the LCD will show `Remaining Pages` with the number of pages you have left to print.

- 3 Press ▲ or ▼ to choose the folder name or file name you want to print. Press **OK**.
If you have chosen the folder name, press ▲ or ▼ to choose the file name you want to print. Press **OK**.

```
Direct Print
▲1. /FOLDER1
  2. FILE_1.PDF
▼3. FILE_2.PDF
Select ▲▼ or OK
```



Note

- Your digital camera must be switched from PictBridge mode to mass storage mode.
- If you want to print an index of the files, choose `Index Print`, and then press **OK**. Press **Start** to print the data.

- 4 Do one of the following:
- Press ▲ or ▼ to choose a setting you need to change and press **OK**, then press ▲ or ▼ to choose an option for the setting and press **OK**.
 - If you do not want to change the current default settings, go to step 5.

```
Print File Set
▲Paper Size
  Media Type
▼Multiple Page
Select ▲▼ or OK
```



Note

- You can choose the following settings:
 - Paper Size
 - Media Type
 - Multiple Page
 - Orientation
 - Duplex
 - Collate
 - Tray Use
 - Print Quality
 - PDF Option
- Depending on the file type, some of these settings may not appear.

- 5 Press **Start** if you have finished selecting settings.

- 6 Press the numeric keys to enter the number of copies you want. Press **OK**.

```
Direct Print
FILE_1.PDF
  No. of Copies: 1
Press Start
```

- 7 Press **Start** to print the data.

- 8 Press **Stop/Exit**.

Important

- To prevent damage to your machine, DO NOT connect any device other than a digital camera or USB Flash memory drive to the USB direct interface.
- DO NOT remove the USB Flash memory drive or digital camera from the USB direct interface until the machine has finished printing.



Note

- You can change the default tray that the machine will use for printing. Press **Menu**, **1**, **5**, **2**, and then press ▲ or ▼ to select the tray you want as the new default. Press **OK**.

(See *Tray Use in print mode* >> page 17.)

- You can change the default settings for Direct Print by using the control panel when the machine is not in the Direct Print mode. Press **Menu**, **4** to enter the USB Direct I/F menu. (See *Menu table* >> page 88.)
-

Printing a document

The machine can receive data from your computer and print it. To print from a computer you must install the printer driver.

(See Software User's Guide: *Printing* for Windows® or *Printing and Faxing* for Macintosh.)

- 1 Install the Brother printer driver from the Installer CD-ROM. (See Quick Setup Guide.)
- 2 From your application, choose the Print command.
- 3 Choose the name of your machine in the **Print** dialog box and click **Properties** (or **Preferences**, depending on the application you are using).
 - Paper Size
 - Orientation
 - Copies
 - Media Type
 - Resolution
 - Print Settings
 - Multiple Page
 - Duplex / Booklet
 - Paper Source
- 5 Click **OK** to begin printing.

Scanning a document as a PDF file using ControlCenter4 (Windows®)

(Detailed information >> Software User's Guide: *Scanning*)



Note

The screens on your PC may vary depending on your model.

ControlCenter4 is a software utility that lets you quickly and easily access the applications you use most often. Using ControlCenter4 eliminates the need to manually launch specific applications. You can use ControlCenter4 on your computer.

- 1 Load your document. (See *How to load documents* >> page 23.)
- 2 Open ControlCenter4 by clicking **Start/All Programs/Brother/XXX-XXXX** (where XXX-XXXX is your model name)/**ControlCenter4**. The ControlCenter4 application will open.
- 3 Choose **Home Mode** or **Advanced Mode** before you use ControlCenter4 and then click **OK**.

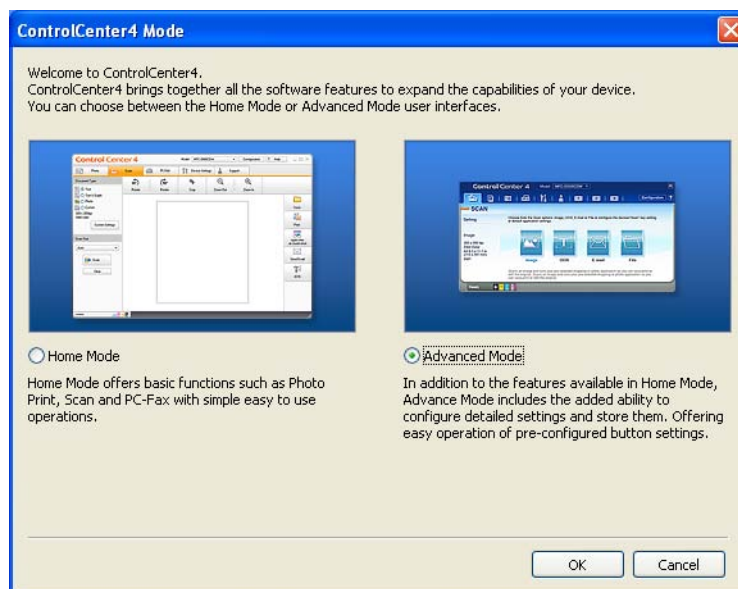

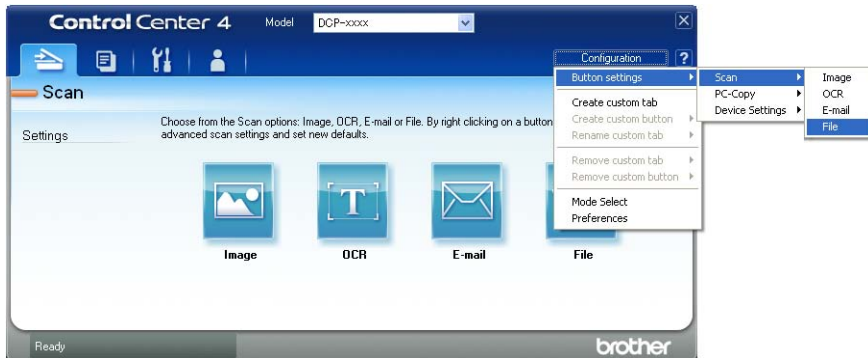

- 4 Make sure the machine you want to use is selected from the **Model** pull-down list.

- 5 Set the scanning configuration. Click **Configuration**, and then select **Button settings**, **Scan** and **File**.

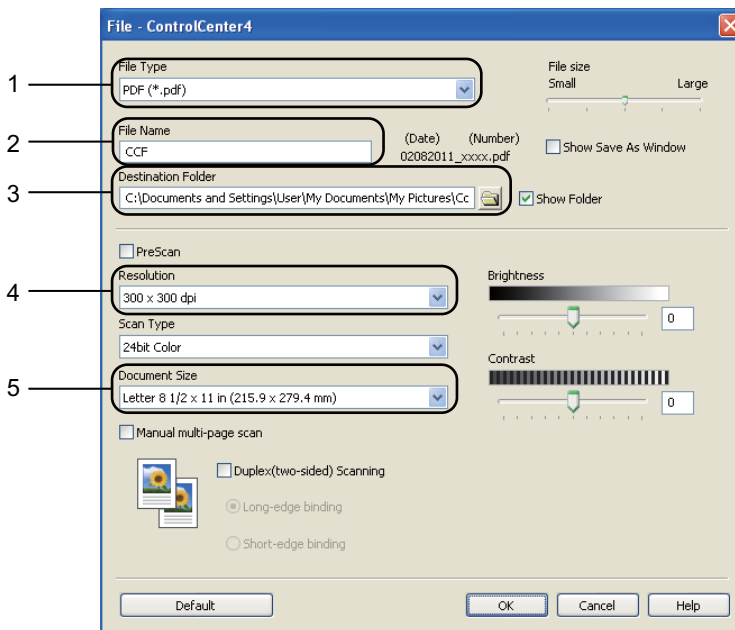

The configuration dialog box appears. You can change the default settings.



- 1 Confirm **PDF (*.pdf)** is selected from the **File Type** pull-down list.
- 2 You can enter the file name you want to use for the document.
- 3 You can save the file to the default folder, or choose your preferred folder by clicking the  (**Browse**) button.
- 4 You can choose a scanning resolution from the **Resolution** pull-down list.
- 5 You can choose the document size from the **Document Size** pull-down list.

- 6 Click **OK**.

- 7 Click **File**.
The machine starts the scanning process. The folder where the scanned data is saved will open automatically.

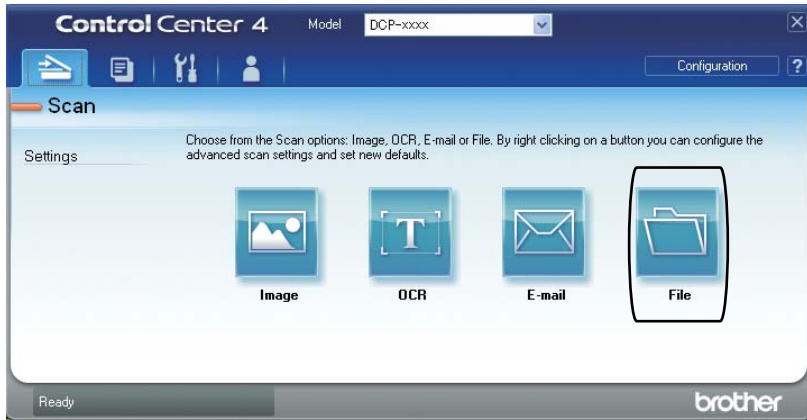

Changing the SCAN key settings

Before scanning

To use the machine as a scanner, install a scanner driver. If the machine is on a network, configure it with a TCP/IP address.

- Install the scanner drivers from the Installer CD-ROM. (See Quick Setup Guide.)
- Configure the machine with a TCP/IP address if network scanning does not work. (See Software User's Guide: *Configuring Network Scanning (Windows®)*.)

SCAN key settings

You can change your machine's **SCAN** key settings using ControlCenter4.

- 1 Open ControlCenter4 by clicking **Start/All Programs/Brother/XXX-XXXX** (where XXX-XXXX is your model name)/**ControlCenter4**. The ControlCenter4 application will open.
- 2 Make sure the machine you want to use is selected from the **Model** pull-down list.
- 3 Click the **Device Settings** tab.
- 4 Click **Device Scan Settings**.

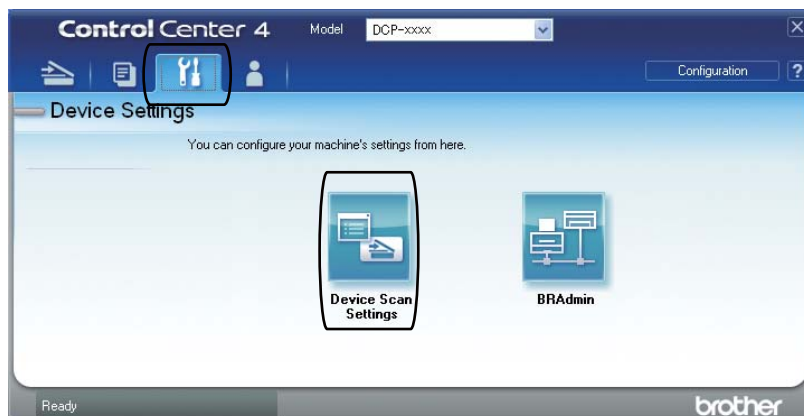

- 5 Choose the **File** tab. You can change the default settings.

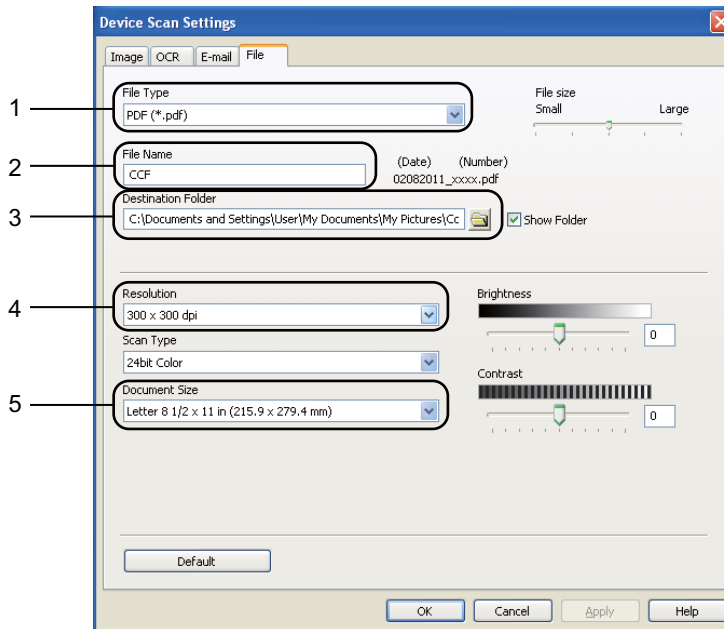

7

- 1 You can choose the file type from the pull-down list.
- 2 You can enter the file name you want to use for the document.
- 3 You can save the file to the default folder, or choose your preferred folder by clicking the  (**Browse**) button.
- 4 You can choose a scanning resolution from the **Resolution** pull-down list.
- 5 You can choose the document size from the **Document Size** pull-down list.

- 6 Click **OK**.

Scanning using the SCAN key

- 1 Load your document. (See *How to load documents* >> page 23.)
- 2 Press  (**SCAN**).
- 3 Press ▲ or ▼ to choose `Scan to PC`.
Press **OK**.
- 4 Press ▲ or ▼ to choose `File`.
Press **OK**.
- 5 (DCP-8155DN)
If you want to change the duplex setting, press ▲ or ▼ to choose `1sided`, `2sided (L) edge` or `2sided (S) edge`.
Press **OK**.
- 6 (For Network users)
Press ▲ or ▼ to choose the destination computer you want to send to.
Press **OK**.
If the LCD prompts you to enter a PIN number, enter the 4-digit PIN number for the destination computer using the numeric keys on the control panel.
Press **OK**.
- 7 Press ▲ or ▼ to choose `Start Scan`.
Press **OK**.
- 8 Press **Start**.
The machine starts the scanning process.



Note

The following scan modes are available:

Scan to:

- USB
- Network (Windows®)
- Image (Scan to PC)
- OCR (Scan to PC)
- E-mail (Scan to PC)
- File (Scan to PC)
- FTP
- Web Service¹ (Web Services Scan)

¹ Windows® users only. (Windows Vista® SP2 or later and Windows® 7)
(See Software User's Guide: *Using Web Services for scanning on your network (Windows Vista® SP2 or greater and Windows® 7)*.)

A

Routine maintenance

Replacing the consumable items

The following messages appear on the LCD in the Ready mode. These messages provide advanced warnings to replace the consumable items before they reach the end of their life. To avoid any inconvenience, you may want to buy spare consumable items before the machine stops printing.



Note

The drum unit and toner cartridge are two separate parts.

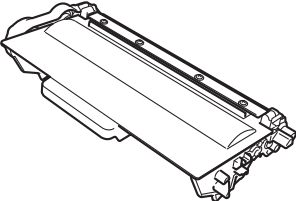
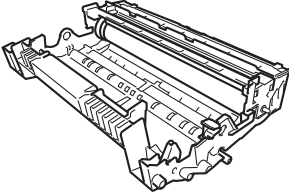
Toner cartridge	Drum unit
See <i>Replacing the toner cartridge</i> >> page 39. Order No. TN-720, TN-750	See <i>Replacing the drum unit</i> >> page 47. Order No. DR-720
	

LCD messages	Consumable item to get ready	Approximate life	How to replace	Order No.
Toner Low	Toner cartridge	3,000 pages ^{1 2 3}	See page 39.	TN-720 ³
Prepare New Toner Cartridge.		8,000 pages ^{1 2 4}		TN-750 ⁴

¹ Letter or A4 size single-sided pages.

² Approx. cartridge yield is declared in accordance with ISO/IEC 19752.

³ Standard toner cartridge

⁴ High yield toner cartridge

You will need to clean the machine regularly and replace the consumable items when the following messages are displayed on the LCD.

LCD messages	Consumable item to replace	Approximate life	How to replace	Order No.
Replace Toner	Toner cartridge	3,000 pages ^{1 2 5}	See page 39.	TN-720 ⁵
		8,000 pages ^{1 2 6}		TN-750 ⁶
Replace Parts Drum	Drum unit	30,000 pages ^{1 3 4}	See page 48.	DR-720
Drum Stop				

¹ Letter or A4 size single-sided pages.

² Approx. cartridge yield is declared in accordance with ISO/IEC 19752.

³ 1 page per job.

⁴ Drum life is approximate and may vary by type of use.

⁵ Standard toner cartridge

⁶ High yield toner cartridge



Note

- Go to <http://www.brother.com/original/index.html> for instructions on how to return your used consumable items to the Brother collection program. If you choose not to return your used consumable, please discard the used consumable according to local regulations, keeping it separate from domestic waste. If you have questions, call your local waste disposal office.
- We recommend placing used consumable items on a piece of paper to prevent accidentally spilling or scattering the material inside.
- If you use paper that is not a direct equivalent for the recommended paper, the life of consumable items and machine parts may be reduced.
- The projected life for each of the toner cartridges is based on ISO/IEC 19752. Frequency of replacement will vary depending on the complexity of printed pages, percentage of coverage and type of media used.

Replacing the toner cartridge

Order No. TN-720, TN-750

The Standard toner cartridge can print approximately 3,000 pages¹. The High Yield toner cartridge can print approximately 8,000 pages¹. Actual page count will vary depending on your average type of document.

When the toner cartridge is running low, the LCD shows `Toner Low`.

The toner cartridge that comes supplied with the machine will need to be replaced after approximately 2,000 pages¹ for DCP-8110DN and approximately 3,000 pages¹ for DCP-8150DN and DCP-8155DN.

¹ Approx. cartridge yield is declared in accordance with ISO/IEC 19752.



Note

- It is a good idea to keep a new toner cartridge ready for use when you see the `Toner Low` warning.
- To ensure high quality printing, we recommend that you use only Genuine Brother Brand toner cartridges. When you want to buy toner cartridges, please call Brother Customer Service.
- If you print graphics, bold text, charts, Web pages with borders, and other types of printouts that consist of more than simple text, the amount of toner used will increase.
- We recommend that you clean the machine when you replace the toner cartridge. (See Advanced User's Guide: *Cleaning and checking the machine.*)
- If you change the print density setting for lighter or darker printing, the amount of toner used will change.
- Wait to unpack the toner cartridge until immediately before you put it into the machine.

Toner Low



If the LCD shows `Toner Low`, buy a new toner cartridge and have it ready before you get a `Replace Toner` message.

Replace Toner

When the following message appears on the LCD, you need to replace the toner cartridge:

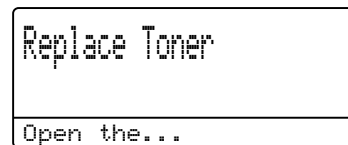

The machine will stop printing until you replace the toner cartridge. A new genuine Brother toner cartridge will reset the `Replace Toner` mode.

Replacing the toner cartridge

- 1 Leave the machine turned on for 10 minutes for the internal fan to cool the extremely hot parts inside the machine.
- 2 Press the front cover release button and then open the front cover.

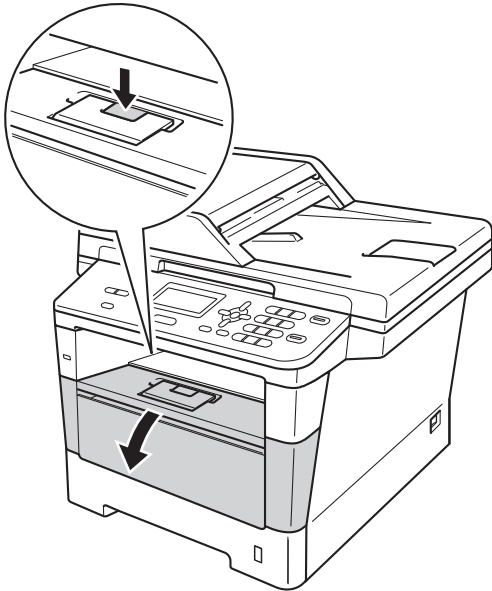

- 3 Take out the drum unit and toner cartridge assembly.

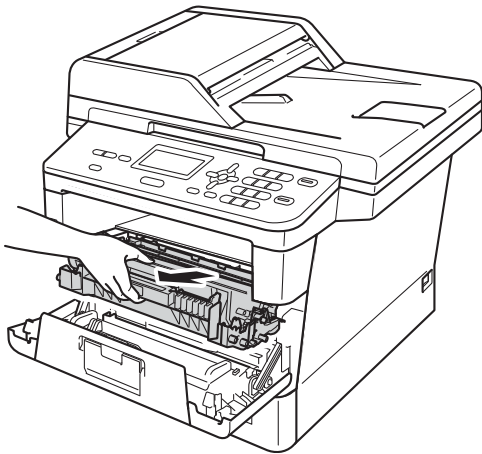

WARNING

HOT SURFACE

After you have just used the machine, some internal parts of the machine will be extremely hot. Wait for the machine to cool down before you touch the internal parts of the machine.

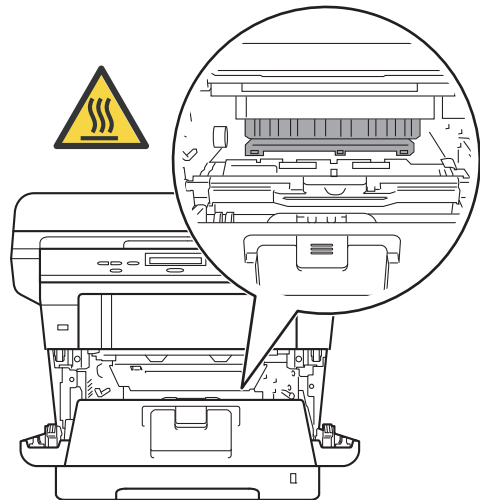

! Important

- We recommend that you place the drum unit and toner cartridge assembly on a clean, flat surface with a piece of disposable paper underneath it in case you accidentally spill or scatter toner.
- To prevent damage to the machine from static electricity, DO NOT touch the electrodes shown in the illustration.

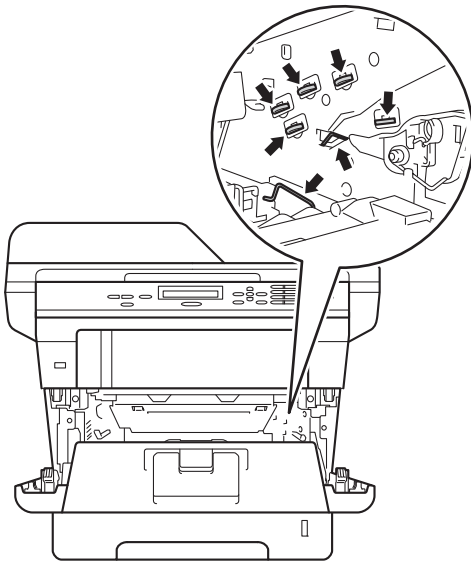

- 4** Push down the green lock lever and take the toner cartridge out of the drum unit.

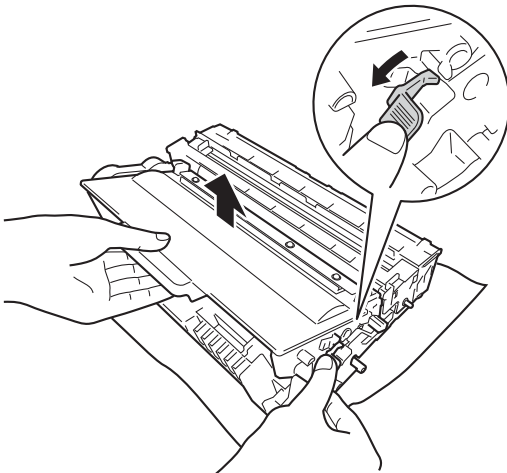

! WARNING



- DO NOT put a toner cartridge or a toner cartridge and drum unit assembly into a fire. It could explode, resulting in injuries.
- DO NOT use flammable substances, any type of spray, or an organic solvent/liquid containing alcohol or ammonia to clean the inside or outside of the machine. Doing so could cause a fire or electrical shock. Instead, use only a dry, lint-free cloth.

(See Product Safety Guide: *To use the product safely.*)



! Important

- Handle the toner cartridge carefully. If toner scatters on your hands or clothes, immediately wipe or wash it off with cold water.
- To avoid print quality problems, DO NOT touch the shaded parts shown in the illustrations.

<Toner cartridge>

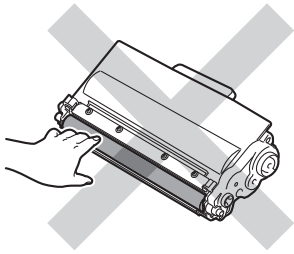

<Drum unit>

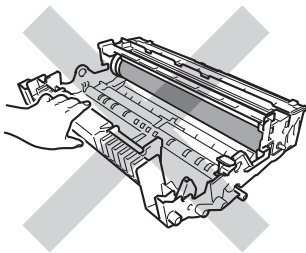

- We recommend that you place the toner cartridge on a clean, flat, level, stable surface with a sheet of disposable paper or cloth underneath it in case you accidentally spill or scatter toner.

✍ Note

- Be sure to seal up the used toner cartridge tightly in a suitable bag so that toner powder does not spill out of the cartridge.
- Go to <http://www.brother.com/original/index.html> for instructions on how to return your used consumable items to the Brother collection program. If you choose not to return your used consumable, please discard the used consumable according to local regulations, keeping it separate from domestic waste. If you have questions, call your local waste disposal office.

5. Unpack the new toner cartridge. Hold the cartridge level with both hands and gently shake it from side to side several times to spread the toner evenly inside the cartridge.

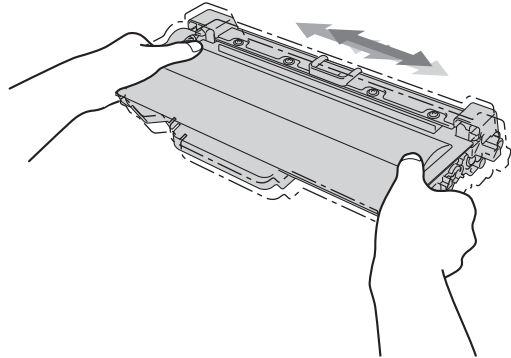

! Important

- Wait to unpack the new toner cartridge until immediately before you put it in the machine. If a toner cartridge is left unpacked for a long time, the toner life will be shortened.
- If an unpacked drum unit is put in direct sunlight or room light, the unit may be damaged.
- Brother strongly recommends that you DO NOT refill the toner cartridge provided with your machine. We also strongly recommend that you continue to use only Genuine Brother Brand replacement toner cartridges. Use or attempted use of third party toner and/or cartridges in the Brother machine may cause damage to the machine and/or may result in unsatisfactory print quality. In addition, use of third party toner and/or cartridges may trigger incorrect status messages, cause the printer to stop prematurely or otherwise malfunction. Our limited warranty coverage does not apply to any problem that is caused by the use of third party toner and/or cartridges. To protect your investment and obtain premium performance from the Brother machine, we strongly recommend the use of Genuine Brother Supplies.

- 6** Pull off the protective cover.

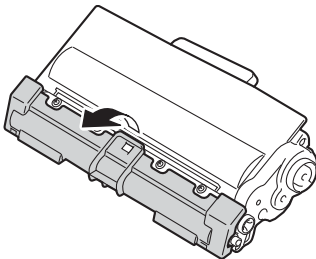

! Important

Put the toner cartridge in the drum unit immediately after you have removed the protective cover. To prevent any degradation to the print quality, DO NOT touch the shaded parts shown in the illustrations.

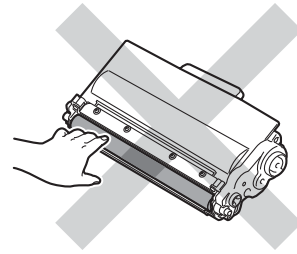

- 7** Put the new toner cartridge firmly into the drum unit until you hear it lock into place. If you put it in correctly, the green lock lever on the drum unit will lift automatically.

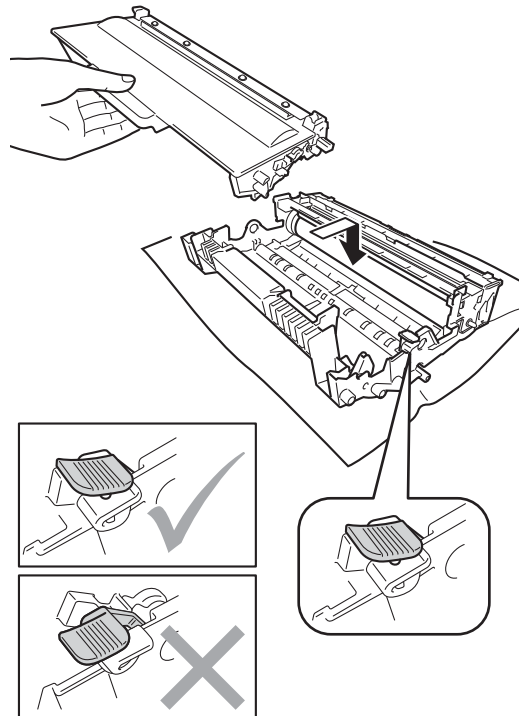

 **Note**

Make sure that you put in the toner cartridge correctly or it may separate from the drum unit.

- 8 Clean the corona wire inside the drum unit by gently sliding the green tab back and forth several times.

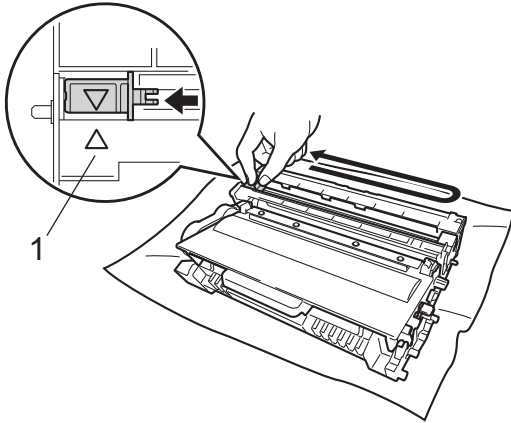

 **Note**

Be sure to return the tab to the home position (▲) (1). If you do not, printed pages may have a vertical stripe.

- 9 Put the drum unit and toner cartridge assembly back into the machine.

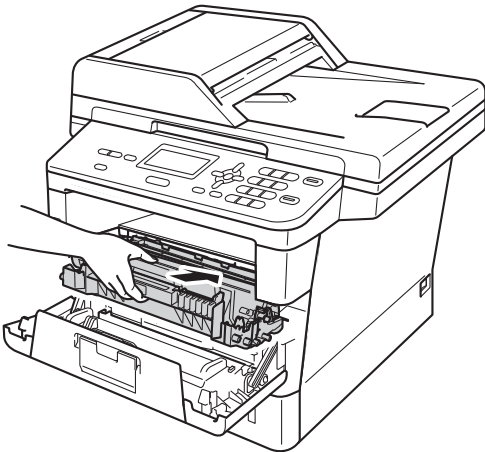

- 10 Close the front cover of the machine.

 **Note**

After you replace a toner cartridge, DO NOT turn off the machine's power switch or open the front cover until the LCD clears the `Please Wait` message and returns to Ready mode.

Cleaning the corona wire

If you have print quality problems or the LCD shows **Drum Error**, clean the corona wire as follows:

- 1 Leave the machine turned on for 10 minutes for the internal fan to cool the extremely hot parts inside the machine.
- 2 Press the front cover release button and then open the front cover.

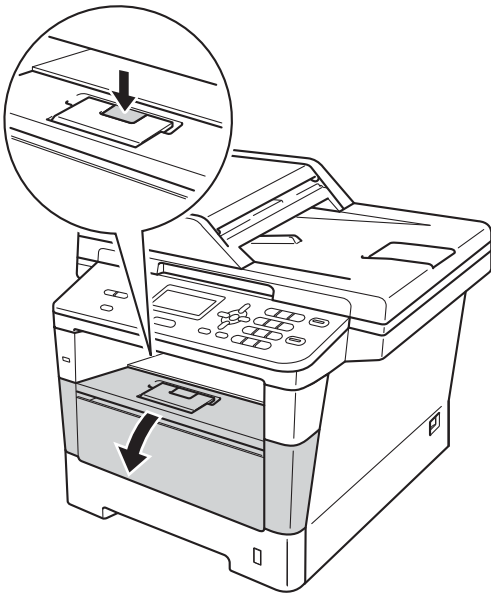

- 3 Take out the drum unit and toner cartridge assembly.

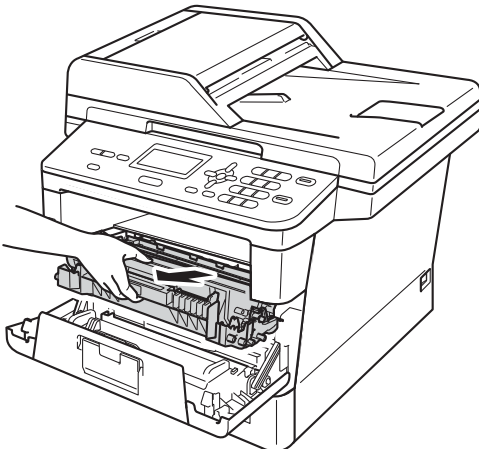

⚠ WARNING

🔥 HOT SURFACE

After you have just used the machine, some internal parts of the machine will be extremely hot. Wait for the machine to cool down before you touch the internal parts of the machine.

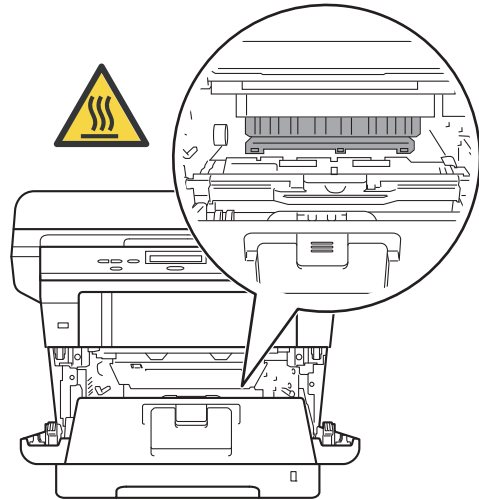

❗ Important

- We recommend that you put the drum unit and toner cartridge assembly on a piece of disposable paper or cloth in case you accidentally spill or scatter toner.
- Handle the drum unit and toner cartridge assembly carefully. If toner scatters on your hands or clothes, immediately wipe or wash it off with cold water.
- To prevent damage to the machine from static electricity, DO NOT touch the electrodes shown in the illustration.

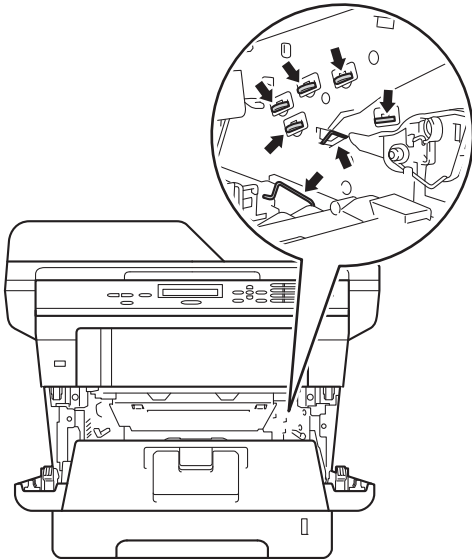

📝 Note

Be sure to return the tab to the home position (▲) (1). If you do not, printed pages may have a vertical stripe.

- 5 Put the drum unit and toner cartridge assembly back into the machine.

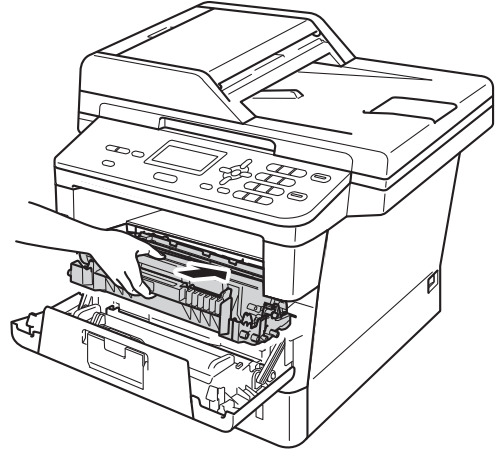

- 6 Close the front cover of the machine.

- 4 Clean the corona wire inside the drum unit by gently sliding the green tab from left to right and right to left several times.

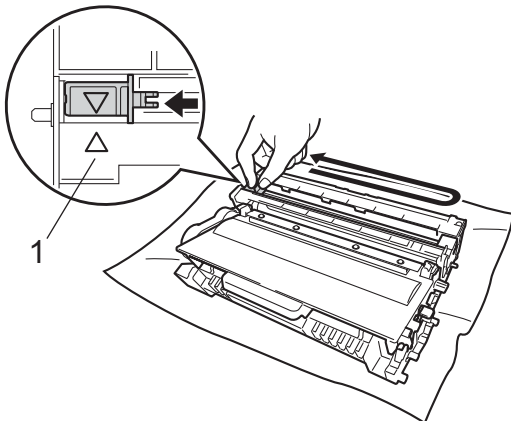

Replacing the drum unit

Order No. DR-720

A new drum unit can print approximately 30,000 Letter or A4 size single-sided pages.

Note

- There are many factors that determine the actual drum life, such as the temperature, humidity, type of paper, type of toner used and so on. Under ideal conditions, the average drum life is estimated at approximately 30,000 pages. The actual number of pages that your drum will print may be significantly less than this estimate. Because we have no control over the many factors that determine the actual drum life, we cannot guarantee a minimum number of pages that will be printed by your drum.
- For best performance, use only genuine Brother toner. The machine should be used only in a clean, dust-free environment with adequate ventilation.
- Printing with a non-Brother drum unit may reduce not only the print quality but also the quality and life of the machine itself. Warranty coverage does not apply to problems caused by the use of a non-Brother drum unit.

Drum Error

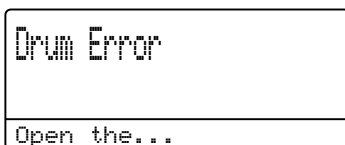

The corona wire has become dirty. Clean the corona wire in the drum unit. (See *Cleaning the corona wire* >> page 45.)

If you cleaned the corona wire and **Drum Error** was not cleared then the drum unit is at the end of its life. Replace the drum unit with a new one.

Replace Parts Drum



The drum unit has exceeded its rated life. Please replace the drum unit with a new one. We recommend a genuine Brother drum unit be installed at this time.

After replacement, reset the drum counter by following the instructions included with the new drum unit. (See *Resetting the drum counter* >> page 51.)

Drum Stop



We cannot guarantee the print quality. Please replace the drum unit with a new one. We recommend a genuine Brother drum unit be installed at this time.

After replacement, reset the drum counter by following the instructions included with the new drum unit. (See *Resetting the drum counter* >> page 51.)

Replacing the drum unit

⚠ Important

- While removing the drum unit, handle it carefully because it may contain toner. If toner scatters on your hands or clothes, immediately wipe or wash it off with cold water.
- Every time you replace the drum unit, clean the inside of the machine. (See *Advanced User's Guide: Cleaning and checking the machine.*)
- Wait to unpack the new drum unit immediately before you put it in the machine. Exposure to direct sunlight or room light may damage the drum unit.

1 Leave the machine turned on for 10 minutes for the internal fan to cool the extremely hot parts inside the machine.

2 Press the front cover release button and then open the front cover.

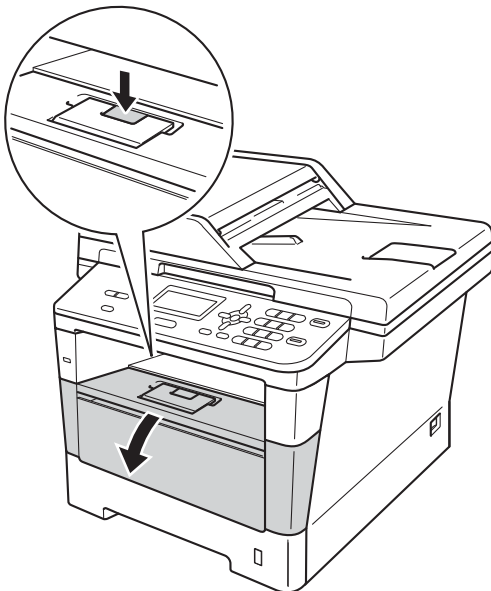

3 Take out the drum unit and toner cartridge assembly.

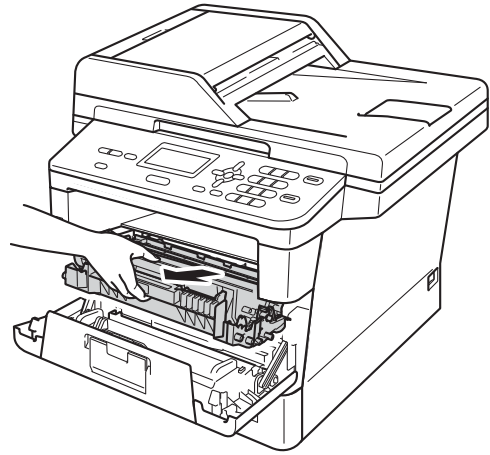

⚠ WARNING

⚠ HOT SURFACE

After you have just used the machine, some internal parts of the machine will be extremely hot. Wait for the machine to cool down before you touch the internal parts of the machine.

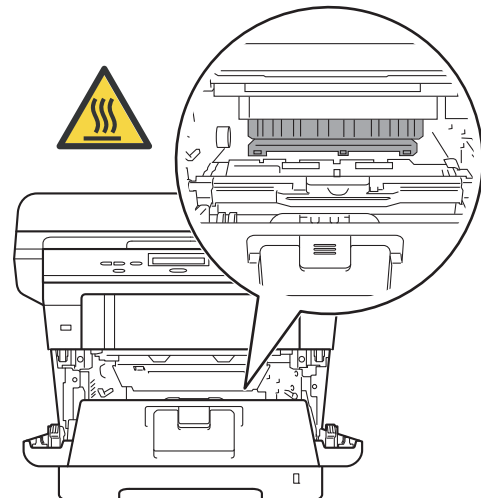

! Important

- We recommend that you place the drum unit and toner cartridge assembly on a clean, flat surface with a piece of disposable paper underneath it in case you accidentally spill or scatter toner.
- To prevent damage to the machine from static electricity, **DO NOT** touch the electrodes shown in the illustration.

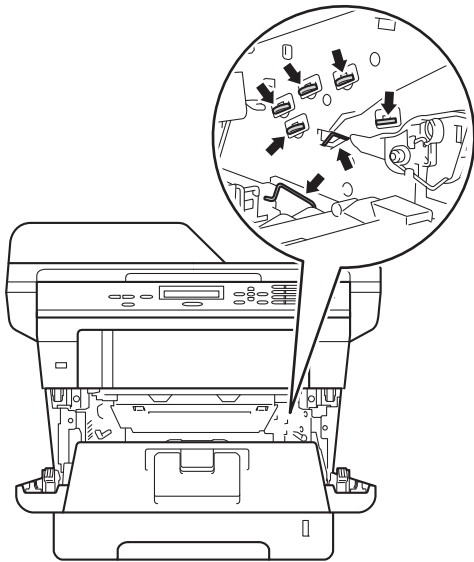

- 4** Push down the green lock lever and take the toner cartridge out of the drum unit.

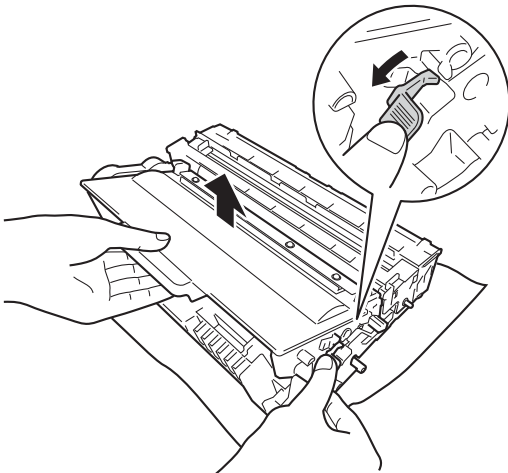

! WARNING



- **DO NOT** put a toner cartridge or a toner cartridge and drum unit assembly into a fire. It could explode, resulting in injuries.
- **DO NOT** use flammable substances, any type of spray, or an organic solvent/liquid containing alcohol or ammonia to clean the inside or outside of the machine. Doing so could cause a fire or electrical shock. Instead, use only a dry, lint-free cloth.

(See Product Safety Guide: *To use the product safely.*)



❗ Important

- Handle the toner cartridge carefully. If toner scatters on your hands or clothes, immediately wipe or wash it off with cold water.
- To avoid print quality problems, DO NOT touch the shaded parts shown in the illustrations.

<Toner cartridge>

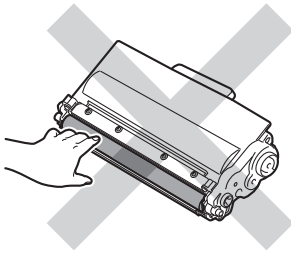

<Drum unit>

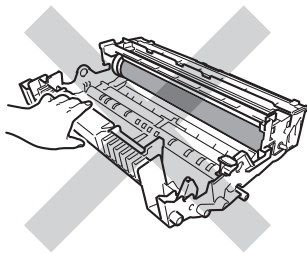

- We recommend that you place the toner cartridge on a clean, flat, level, stable surface with a sheet of disposable paper or cloth underneath it in case you accidentally spill or scatter toner.

📄 Note

- Be sure to seal up the used drum unit tightly in a suitable bag so that toner powder does not spill out of the drum unit.
- Go to <http://www.brother.com/original/index.html> for instructions on how to return your used consumable items to the Brother collection program. If you choose not to return your used consumable, please discard the used consumable according to local regulations, keeping it separate from domestic waste. If you have questions, call your local waste disposal office.

- 5 Unpack the new drum unit.
- 6 Put the toner cartridge firmly into the new drum unit until you hear it lock into place. If you put the cartridge in correctly, the green lock lever will lift automatically.

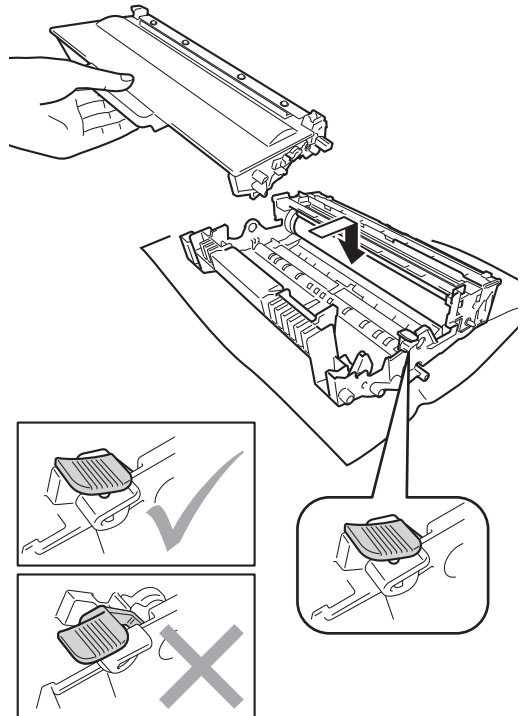



Note

Make sure that you put in the toner cartridge correctly or it may separate from the drum unit.

- 7 Put the drum unit and toner cartridge assembly back into the machine. Do not close the front cover of the machine.

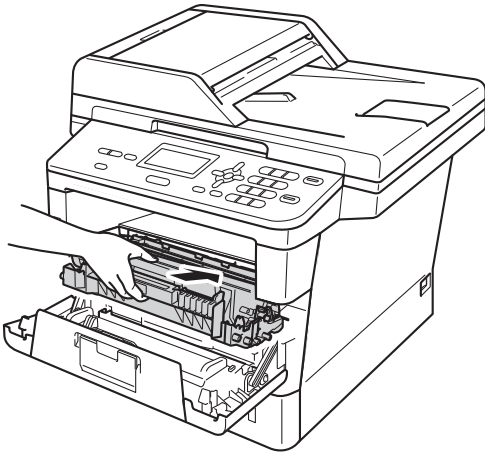

A

Resetting the drum counter

When you replace a drum unit with a new one, you need to reset the drum counter by completing the following steps:

! Important

Do not reset the drum counter when you only replace the toner cartridge.

- 1 With the front cover still open, press **Clear**.

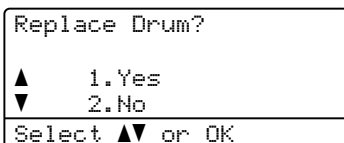

- 2 To confirm you are installing a new drum, press **1**.
- 3 When the LCD shows *Accepted*, close the front cover of the machine.

B

Troubleshooting

If you think there is a problem with your machine, check each of the items below first and then follow the troubleshooting tips.

You can correct most problems by yourself. If you need additional help, the Brother Solutions Center offers the latest FAQs and troubleshooting tips.

Visit us at <http://solutions.brother.com/>.

Identifying your problem

First, check the following:

- The machine's power cord is connected correctly and the machine's power switch is turned on. If the machine does not turn on after connecting the power cord, see *Other difficulties* >> page 77.
- All of the protective parts have been removed.
- Paper is inserted correctly in the paper tray.
- The interface cables are securely connected to the machine and the computer.
- LCD Messages
(See *Error and maintenance messages* >> page 53)

If you did not solve your problem with the above checks, identify your problem and then go to the page suggested below.

Paper handling and Printing problems:

- *Printing difficulties* >> page 72
- *Paper handling difficulties* >> page 74

Copying problems:

- *Copying difficulties* >> page 75

Scanning problems:

- *Scanning difficulties* >> page 75

Software and Network problems:

- *Software difficulties* >> page 75
- *Network difficulties* >> page 76

Error and maintenance messages

As with any sophisticated office product, errors may occur and consumable items may need to be replaced. If this happens, your machine identifies the error or required routine maintenance and shows the appropriate message. The most common error and maintenance messages are shown below.

You can correct most errors and perform routine maintenance by yourself. If you need more help, the Brother Solutions Center offers the latest FAQs and troubleshooting tips:

Visit us at <http://solutions.brother.com/>.

Error Message	Cause	Action
Access Denied	The function you want to use is restricted by Secure Function Lock 2.0.	Contact your administrator to check your Secure Function Lock Settings.
Access Error	The device is removed from the USB direct interface while the data is processing.	Press Stop/Exit . Reinsert the device and try to print with Direct Print.
Cartridge Error Put the Toner Cartridge back in.	The toner cartridge is not installed correctly.	Pull out the drum unit and toner cartridge assembly, take out the toner cartridge, and put it back into the drum unit again. Put the drum unit and toner cartridge assembly back in the machine.
Cooling Down Wait for a while	The temperature of the drum unit or toner cartridge is too hot. The machine will pause its current print job and go into cooling down mode. During the cooling down mode, you will hear the cooling fan running while the LCD shows Cooling Down, and Wait for a while .	<p>Make sure that you can hear the fan in the machine spinning and that the exhaust outlet is not blocked by something.</p> <p>If the fan is spinning, remove any obstacles that surround the exhaust outlet, and then leave the machine turned on but do not use it for several minutes.</p> <p>If the fan is not spinning, disconnect the machine from the power for several minutes, then reconnect it.</p>
Cover is Open	The front cover is not completely closed.	Close the front cover of the machine.
	The ADF cover is not completely closed.	Close the ADF cover of the machine.
	The ADF is open while loading a document.	Close the ADF cover of the machine, then press Stop/Exit .
	The fuser cover is not completely closed or paper was jammed in the back of the machine when you turned on the power.	<ul style="list-style-type: none"> ■ Close the fuser cover of the machine. ■ Make sure paper is not jammed inside the back of the machine, and then close the fuser cover and press Start. <p>(See <i>Paper is jammed at the back of the machine</i> >> page 63.)</p>



Error Message	Cause	Action
DIMM Error	<ul style="list-style-type: none"> ■ The DIMM is not installed correctly. ■ The DIMM is broken. ■ The DIMM does not meet the required specifications. 	<ul style="list-style-type: none"> ■ Turn off the machine and remove the DIMM. (See Advanced User's Guide: <i>Installing extra memory</i>.) ■ Confirm the DIMM meets the required specifications. (See Advanced User's Guide: <i>Memory board</i>.) ■ Re-install the DIMM correctly. Wait a few seconds, and then turn it on again. ■ If this error message appears again, replace the DIMM with a new one. (See Advanced User's Guide: <i>Installing extra memory</i>.)
Document Jam	The document was not inserted or fed correctly, or the document scanned from the ADF was too long.	See <i>Document is jammed in the top of the ADF unit</i> >> page 59 or <i>Using the automatic document feeder (ADF)</i> >> page 23.
Drum Error	The corona wire on the drum unit needs to be cleaned.	Clean the corona wire on the drum unit. (See <i>Cleaning the corona wire</i> >> page 45.)
	The toner cartridge is placed in the machine without the drum unit.	Put the toner cartridge into the drum unit, and then re-install the drum unit and toner cartridge assembly in the machine.
Drum Stop	It is time to replace the drum unit.	Replace the drum unit. (See <i>Replacing the drum unit</i> >> page 48.)
Duplex Disabled	The back of the machine is not closed completely.	Close the back cover of the machine.
Fuser Error	The temperature of the fuser unit does not rise to a specified temperature within the specified time.	Turn the power switch off, wait a few seconds, and then turn it on again. Leave the machine for 15 minutes with the power on.
	The fuser unit is too hot.	
Jam Duplex	The paper is jammed in the duplex tray or the fuser unit.	See <i>Paper is jammed in the duplex tray</i> >> page 70.
Jam Inside	The paper is jammed inside the machine.	See <i>Paper is jammed inside the machine</i> >> page 66.
	The toner cartridge is placed in the machine without the drum unit.	Put the toner cartridge into the drum unit, and then re-install the drum unit and toner cartridge assembly in the machine.
Jam MP Tray	The paper is jammed in the MP tray of the machine.	See <i>Paper is jammed in the MP tray</i> >> page 61.
Jam Rear	The paper is jammed in the back of the machine.	See <i>Paper is jammed at the back of the machine</i> >> page 63.

Error Message	Cause	Action
Jam Tray 1 Jam Tray 2	The paper is jammed in the paper tray of the machine.	See <i>Paper is jammed in paper tray 1 or tray 2</i> >> page 62.
Limit Exceeded	The printing limit set by Secure Function Lock 2.0 was reached.	Contact your administrator to check your Secure Function Lock Settings.
Log Access Error	The machine could not access the print log file in the server.	Contact your administrator to check the Store Print Log to Network settings. For detailed information >> Network User's Guide: <i>Store Print Log to Network</i>
Manual Feed	Manual was selected as the paper source when there was no paper in the MP tray.	Place paper in the MP tray. If the machine is in Pause mode, press Start . (See <i>Loading paper in the multi-purpose tray (MP tray)</i> >> page 11)
No HUB Support	A USB hub device is connected to the USB direct interface.	Disconnect the USB hub device from the USB direct interface.
No Paper	The machine is out of paper in the specified tray or all trays, or paper is not correctly loaded in the paper tray.	Do one of the following: <ul style="list-style-type: none"> ■ Refill paper in the paper tray shown on the LCD. Make sure the paper guides are set to the correct size. ■ Remove the paper and load it again. Make sure the paper guides are set to the correct size.
No Toner	The toner cartridge or the drum unit and toner cartridge assembly is not installed correctly.	Remove the drum unit and toner cartridge assembly, remove the toner cartridge from the drum unit, and re-install the toner cartridge back into the drum unit again. Re-install the drum unit and toner cartridge assembly back in the machine. If the problem continues, replace the toner cartridge. (See <i>Replacing the toner cartridge</i> >> page 39.)
No Tray	The standard paper tray is not installed or not installed correctly.	Re-install the standard paper tray.
Not Available	The requested function is not permitted to all User IDs by Secure Function Lock 2.0.	Contact your administrator to check your Secure Function Lock Settings.

Error Message	Cause	Action
Out of Memory	The machine's memory is full.	<p>Copy operation in process</p> <p>Do one of the following:</p> <ul style="list-style-type: none"> ■ Press Start to copy the scanned pages. ■ Press Stop/Exit and wait until the other operations in progress finish, and then try again. ■ Add optional memory. (See Advanced User's Guide: <i>Memory board</i>.) <p>Print operation in process</p> <p>Do one of the following:</p> <ul style="list-style-type: none"> ■ Reduce the print resolution. (See Software User's Guide: <i>Printing</i> (for Windows®) or <i>Printing and Faxing</i> (for Macintosh).) ■ Add optional memory. (See Advanced User's Guide: <i>Memory board</i>.)
Out of Memory Secure Print Data is full.	The machine's memory is full.	<p>Press Stop/Exit and delete the previously stored secure print data. (See Software User's Guide: <i>Secure Print Key</i>.)</p>
Print Unable XX	The machine has a mechanical problem.	<p>Do one of the following:</p> <ul style="list-style-type: none"> ■ Turn the power switch off, wait a few minutes, and then turn it on again. ■ If the problem continues, call Brother Customer Service.
Protected Device	The protect switch of the USB Flash memory drive is on.	Turn off the protect switch of the USB Flash memory drive.
Rename the File	There is already a file on the USB Flash memory drive with the same name as the file you are trying to save.	Change the file name of the file on the USB Flash memory drive or the file you are trying to save.
Replace Parts Drum	It is time to replace the drum unit.	<p>Replace the drum unit. (See <i>Replacing the drum unit</i> >> page 48.)</p>
	The drum unit counter was not reset when a new drum was installed.	<p>Reset the drum unit counter. (See <i>Resetting the drum counter</i> >> page 51.)</p>

Error Message	Cause	Action
Replace Parts Fuser Unit	It is time to replace the fuser unit.	Call Brother Customer Service or a Brother Authorized Service Center to replace the fuser unit. To replace Fuser Unit call Brother Customer Service at: 1-877-BROTHER (1-877-276-8437) (in USA) 1-877-BROTHER (in Canada) or to locate a Brother Authorized Service Center, visit us at: http://www.brother-usa.com/service/
Replace Parts Laser Unit	It is time to replace the laser unit.	Call Brother Customer Service or a Brother Authorized Service Center to replace the laser unit. To replace Laser Unit call Brother Customer Service at: 1-877-BROTHER (1-877-276-8437) (in USA) 1-877-BROTHER (in Canada) or to locate a Brother Authorized Service Center, visit us at: http://www.brother-usa.com/service/
Replace Parts PF Kit 1 PF Kit 2 PF Kit MP	It is time to replace the paper feeding kit.	Call Brother Customer Service or a Brother Authorized Service Center to replace the PF Kit. To replace PF Kit call Brother Customer Service at: 1-877-BROTHER (1-877-276-8437) (in USA) 1-877-BROTHER (in Canada) or to locate a Brother Authorized Service Center, visit us at: http://www.brother-usa.com/service/
Replace Toner	The toner cartridge is at the end of its life. The machine will stop all print operations.	Replace the toner cartridge. (See <i>Replacing the toner cartridge</i> >> page 39.)
Scan Unable XX	The machine has a mechanical problem.	<ul style="list-style-type: none"> ■ Turn the power switch off, and then turn it on again. ■ If the problem continues, call Brother Customer Service.
	Document is too long for duplex scanning.	Press Stop/Exit . Use a suitable size of paper for duplex scanning. (See <i>Paper capacity of the paper trays</i> >> page 19.)
Size Error	The paper size defined in the printer driver is not suitable for the tray you are using.	Choose a paper size which is supported by the tray shown on the LCD. (See <i>Paper Size</i> >> page 16.)



Error Message	Cause	Action
Size Error DX	The paper size defined in the printer driver and the control panel menu is not suitable for automatic duplex printing.	Press Stop/Exit . Choose a paper size which is supported by the duplex tray. The paper size you can use for automatic duplex printing is Letter, Legal or Folio.
	The paper in the tray is not the correct size and is not suitable for automatic duplex printing.	Press Start . Load the correct size of paper in the tray and set the "Paper Size" (Menu, 1, 1, 2). The paper size you can use for automatic duplex printing is Letter, Legal or Folio.
Size mismatch	The paper in the tray is not the correct size.	Load the correct size of paper in the tray and set the "Paper Size" (Menu, 1, 1, 2). (See <i>Paper Size</i> >> page 16.)
Toner Low	If the LCD shows Toner Low you can still print; however, the machine is telling you that the toner cartridge is near the end of its life.	Order a new toner cartridge now so a replacement toner cartridge will be available when the LCD shows Replace Toner .
Too Many Files	There are too many files stored on the USB Flash memory drive.	Reduce the number of files stored on the USB Flash memory drive.
Unusable Device Remove the Device. Turn the power off and back on again.	A defective USB device or a high power consumption USB device has been connected to the USB direct interface.	Unplug the device from the USB direct interface. Turn the machine off and then on again.
Unusable Device	A USB device or USB Flash memory drive that is encrypted or not supported has been connected to the USB direct interface.	Unplug the device from the USB direct interface. See the specifications for supported USB Flash memory drives in <i>Printing data from a USB Flash memory drive or digital camera supporting mass storage</i> >> page 26.
Wrong Paper Size	The machine cannot find paper of the same size in another tray when the paper tray in use has run out of paper during a copy operation.	Load the paper in the paper tray shown on the LCD.

Document Jams

Document is jammed in the top of the ADF unit

- 1 Take out any paper from the ADF that is not jammed.
- 2 Open the ADF cover.
- 3 Pull the jammed document out to the left.

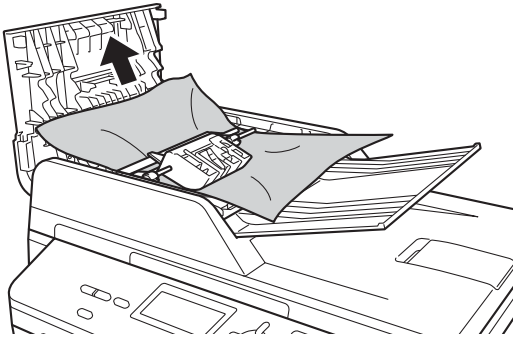

If the document rips or tears, be sure you remove all small paper scraps to prevent future jams.

- 4 Close the ADF cover.
- 5 Press **Stop/Exit**.

Document is jammed under the document cover

- 1 Take out any paper from the ADF that is not jammed.
- 2 Lift the document cover.
- 3 Pull the jammed document out to the right.

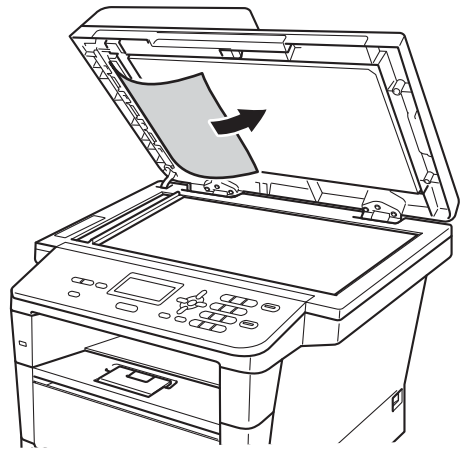

If the document rips or tears, be sure you remove all small paper scraps to prevent future jams.

- 4 Close the document cover.
- 5 Press **Stop/Exit**.

Removing small documents jammed in the ADF

- 1 Lift the document cover.
- 2 Insert a piece of stiff paper, such as cardstock, into the ADF to push any small paper scraps through.

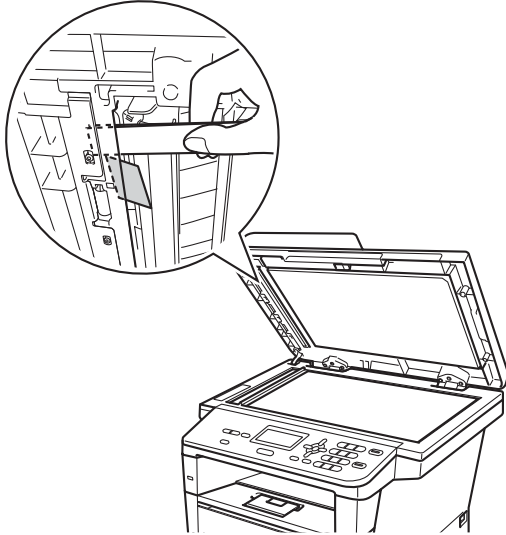

- 3 Close the document cover.
- 4 Press **Stop/Exit**.

Document is jammed at the output tray

- 1 Take out any paper from the ADF that is not jammed.
- 2 Pull the jammed document out to the right.



- 3 Press **Stop/Exit**.

Paper Jams

Always remove all paper from the paper tray and straighten the stack when you add new paper. This helps prevent paper jams and multiple sheets of paper from feeding through the machine at the same time.

Paper is jammed in the MP tray

If the LCD shows **Jam MP Tray**, follow these steps:

- 1 Remove the paper from the MP tray.
- 2 Remove any jammed paper from in and around the MP tray.

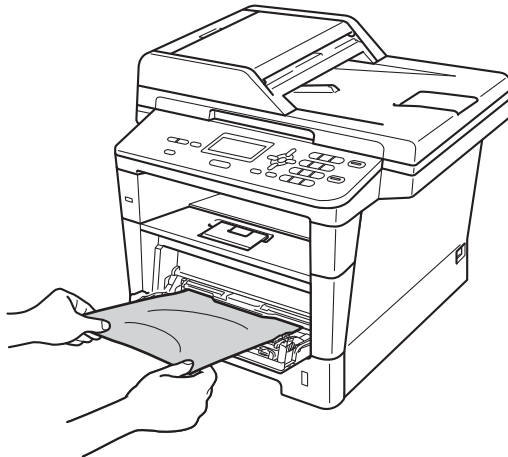

- 3 Fan the paper stack, and then put it back in the MP tray.

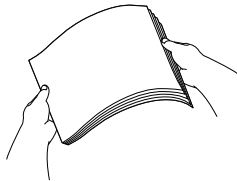

- 4 When loading paper in the MP tray, make sure that the paper stays under the maximum paper height guides (1) on both sides of the tray.

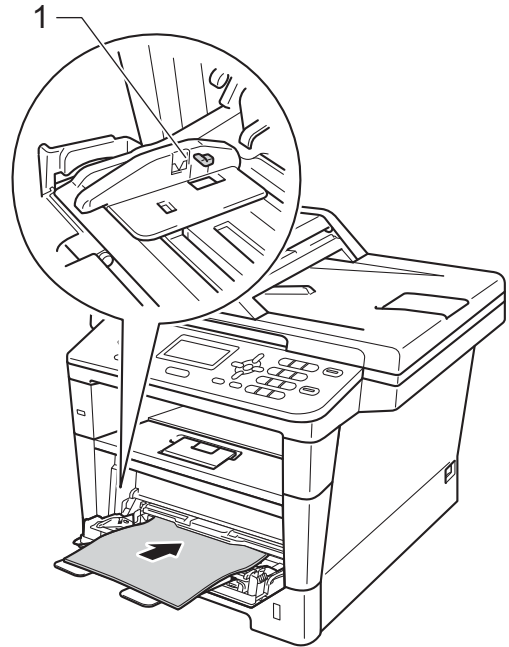

- 5 Press **Start** to resume printing.

B

Paper is jammed in paper tray 1 or tray 2

If the LCD shows Jam Tray 1 or Jam Tray 2, follow these steps:

- 1 Pull the paper tray completely out of the machine.

For Jam Tray 1:

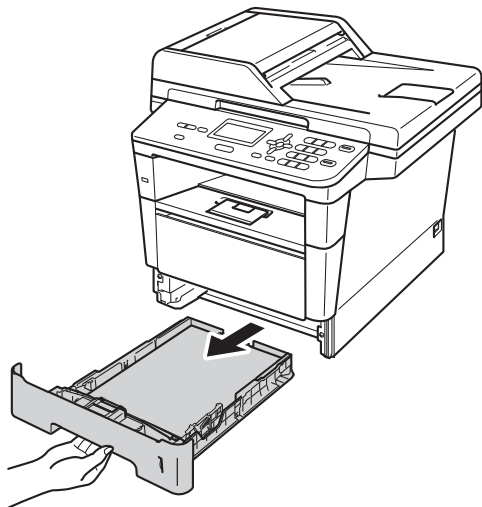

For Jam Tray 2:

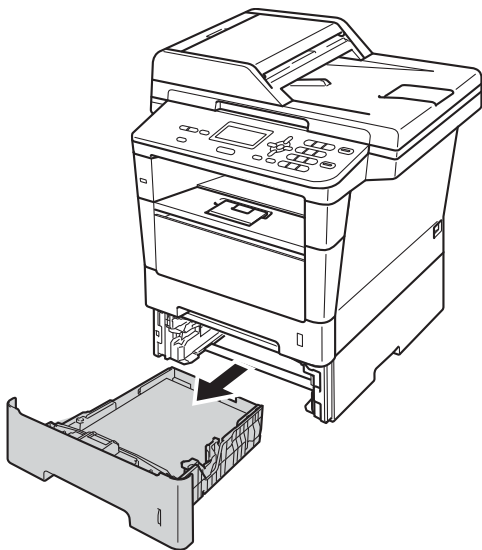

- 2 Use both hands to slowly pull out the jammed paper.

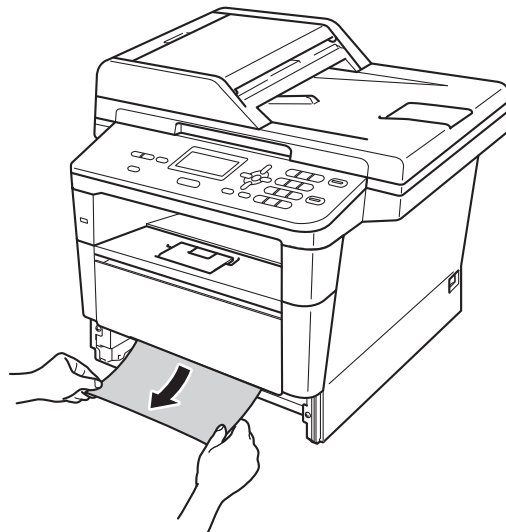

Note

Pulling the jammed paper downward allows you to remove the paper easier.

- 3 Make sure that the paper is below the maximum paper mark (▼▼▼) in the paper tray. While pressing the green paper-guide release lever, slide the paper guides to fit the paper size. Make sure that the guides are firmly in the slots.
- 4 Put the paper tray firmly back in the machine.

Paper is jammed at the back of the machine

If the LCD shows **Jam Rear**, a paper jam occurred behind the back cover. Follow these steps:

- 1 Leave the machine turned on for 10 minutes for the internal fan to cool the extremely hot parts inside the machine.
- 2 Press the front cover release button and then open the front cover.

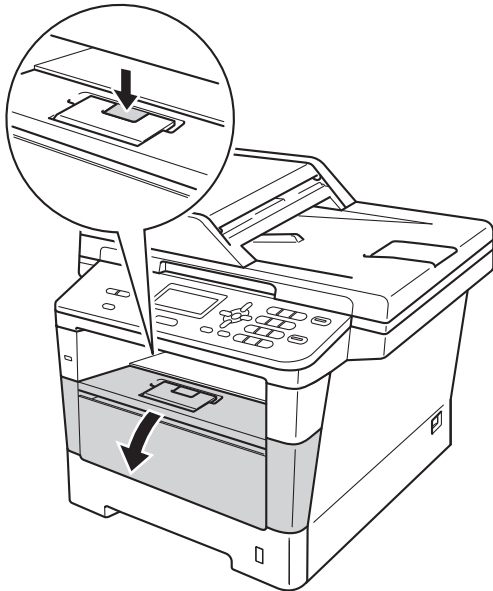

- 3 Slowly take out the drum unit and toner cartridge assembly. The jammed paper may be pulled out with the drum unit and toner cartridge assembly, or this may release the paper so you can pull it out from inside of the machine.

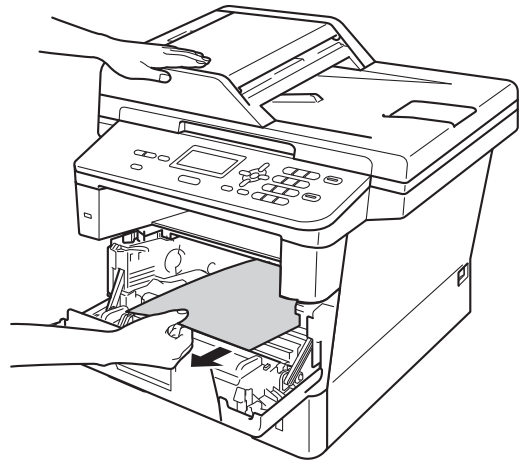
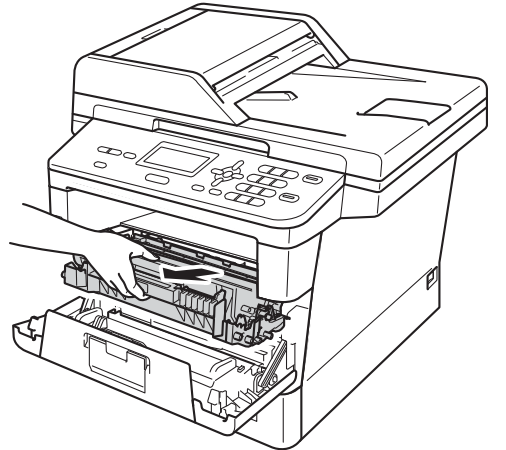

WARNING

HOT SURFACE

After you have just used the machine, some internal parts of the machine will be extremely hot. Wait for the machine to cool down before you touch the internal parts of the machine.

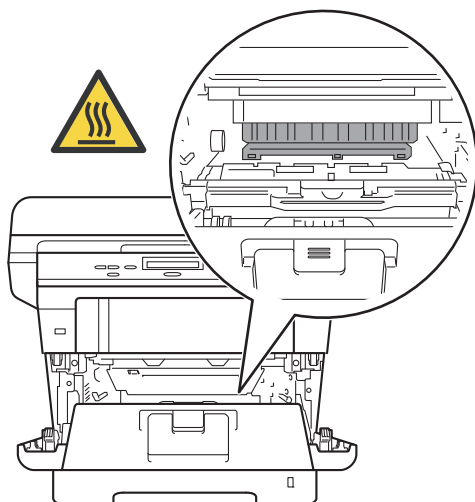

Important

- We recommend that you put the drum unit and toner cartridge assembly on a piece of disposable paper or cloth in case you accidentally spill or scatter toner.
- Handle the drum unit and toner cartridge assembly carefully. If toner scatters on your hands or clothes, immediately wipe or wash it off with cold water.
- To prevent damage to the machine from static electricity, DO NOT touch the electrodes shown in the illustration.

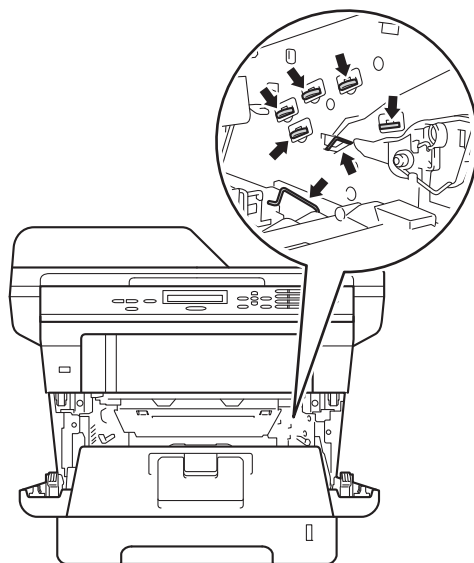

- 4 Open the back cover.

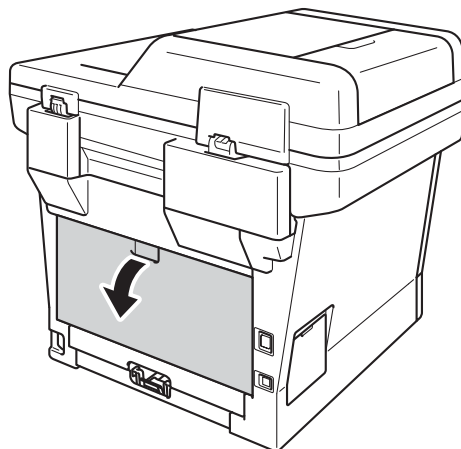

! WARNING

! HOT SURFACE

After you have just used the machine, some internal parts of the machine will be extremely hot. Wait for the machine to cool down before you touch the internal parts of the machine.

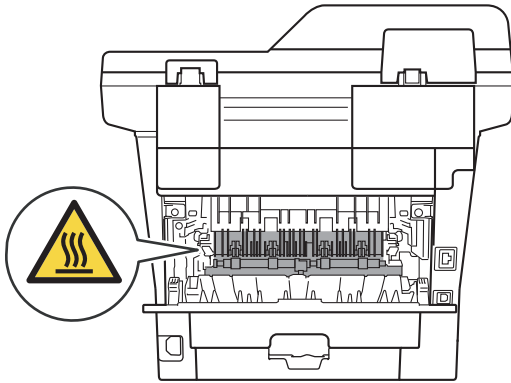

- 5** Pull the green tabs at the left and right hand sides toward you and fold down the fuser cover (1).

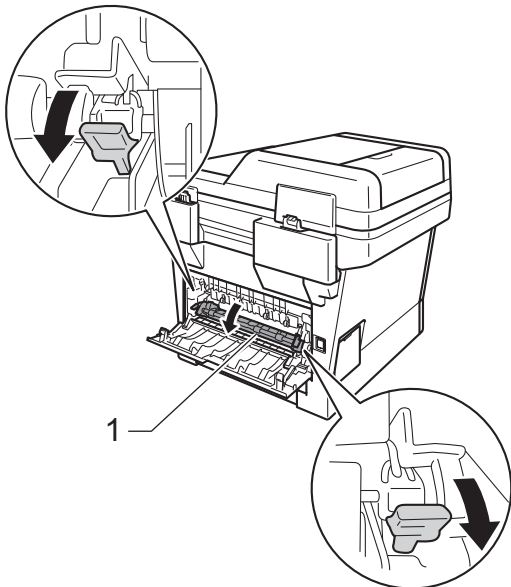

- 6** Using both hands, gently pull the jammed paper out of the fuser unit.

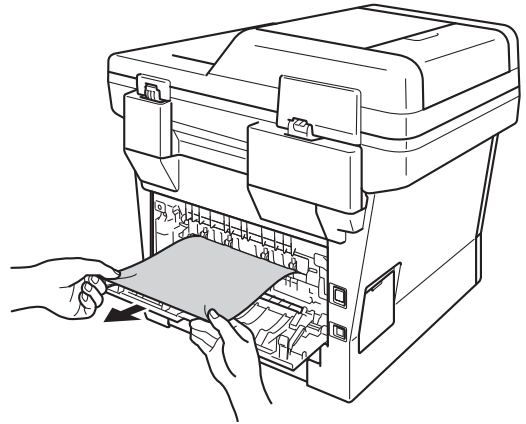

- 7** Close the fuser cover (1).

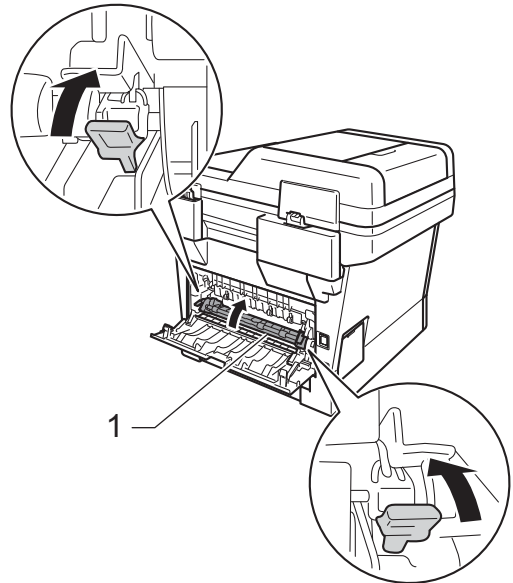

- 8** Close the back cover.

- 9 Put the drum unit and toner cartridge assembly back into the machine.

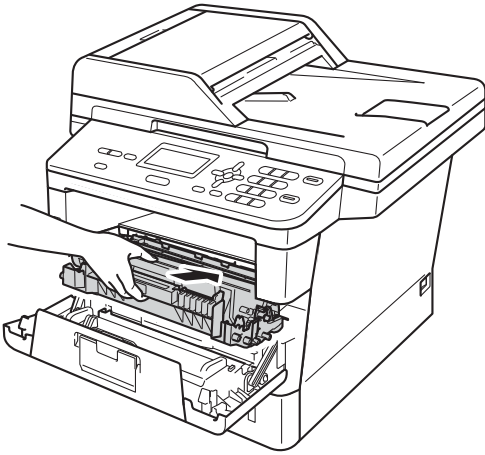

- 10 Close the front cover of the machine.

Paper is jammed inside the machine

If the LCD shows *Jam Inside*, follow these steps:

- 1 Leave the machine turned on for 10 minutes for the internal fan to cool the extremely hot parts inside the machine.
- 2 Pull the paper tray completely out of the machine.

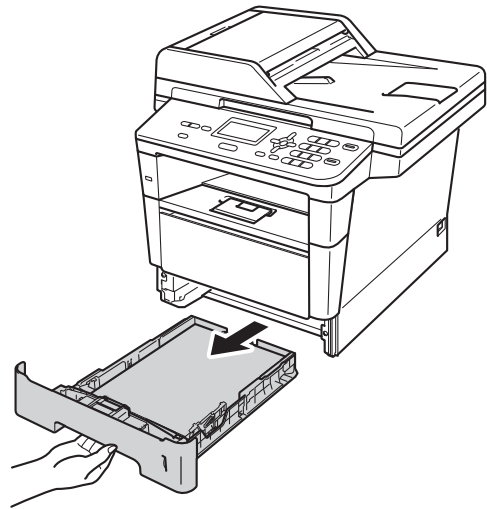

- 3 Use both hands to slowly pull out the jammed paper.

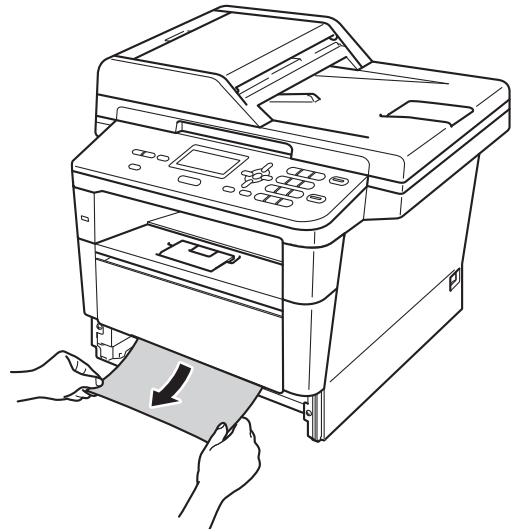



Note

Pulling the jammed paper downward allows you to remove the paper easier.

- 4 Press the front cover release button and then open the front cover.



- 5 Slowly take out the drum unit and toner cartridge assembly. The jammed paper may be pulled out with the drum unit and toner cartridge assembly, or this may release the paper so you can pull it out from inside of the machine.

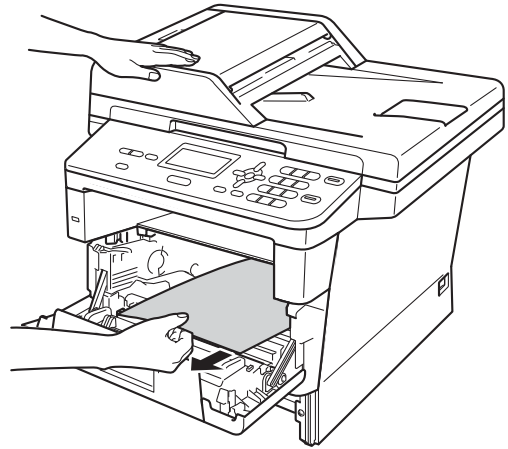
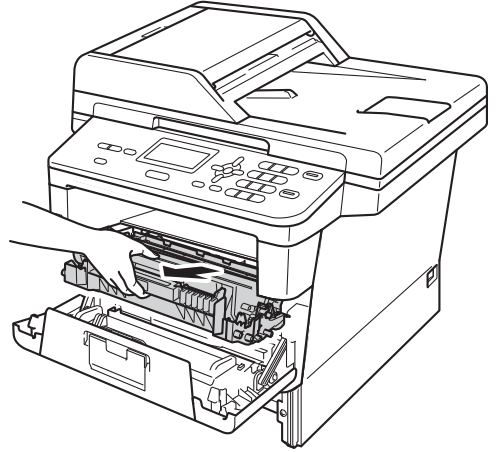

WARNING

HOT SURFACE

After you have just used the machine, some internal parts of the machine will be extremely hot. Wait for the machine to cool down before you touch the internal parts of the machine.

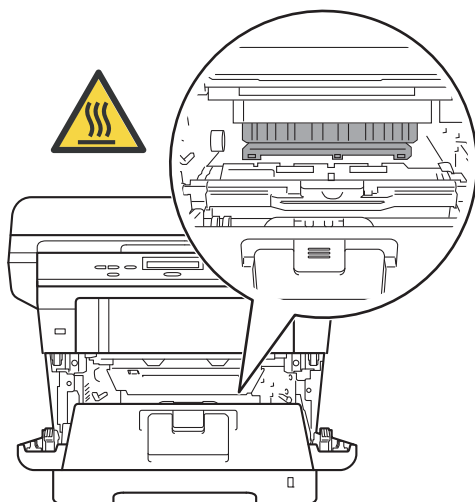

Important

- We recommend that you put the drum unit and toner cartridge assembly on a piece of disposable paper or cloth in case you accidentally spill or scatter toner.
- Handle the drum unit and toner cartridge assembly carefully. If toner scatters on your hands or clothes, immediately wipe or wash it off with cold water.
- To prevent damage to the machine from static electricity, DO NOT touch the electrodes shown in the illustration.

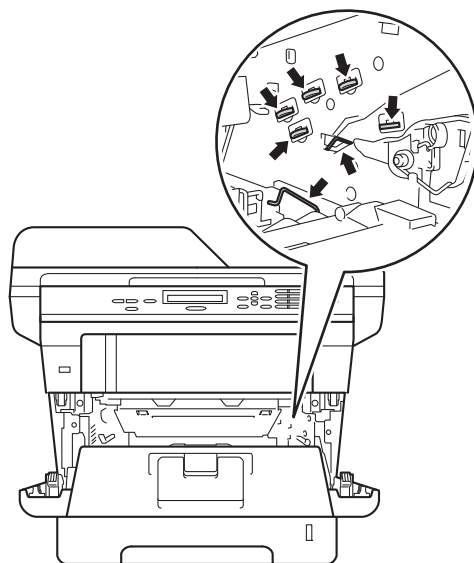

Note

The drum unit and toner cartridge are two separate parts. Make sure both are installed as an assembly. If the toner cartridge is placed in the machine without the drum unit, the messages `Drum Error` or `Jam Inside` may be displayed.

- 6 Push down the green lock lever and take the toner cartridge out of the drum unit. Remove the jammed paper if there is any inside the drum unit.

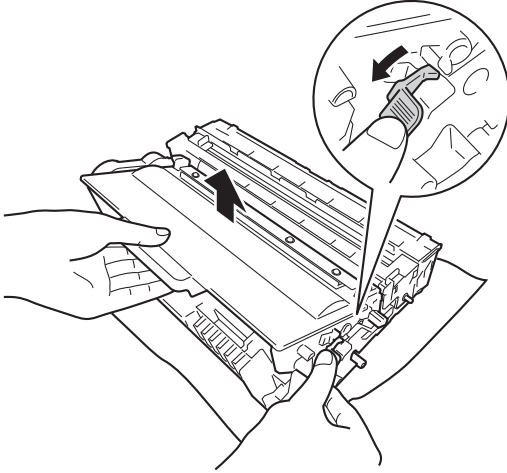

- 7 Put the toner cartridge back into the drum unit until you hear it lock into place. If you put the cartridge in correctly, the green lock lever will lift automatically.

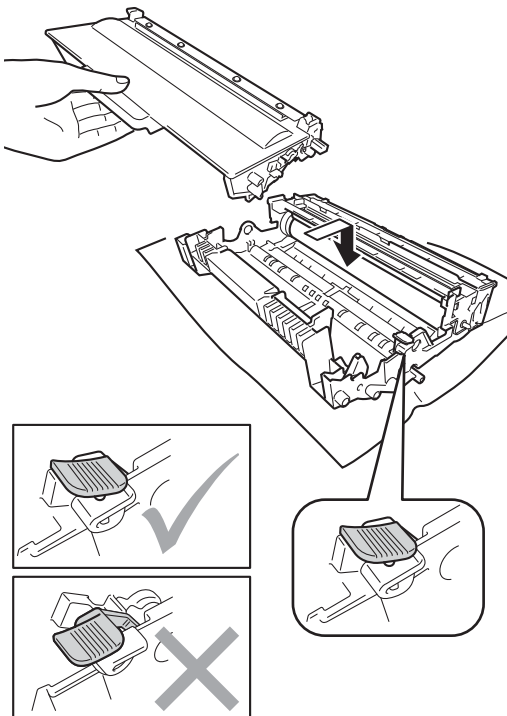

 **Note**

Make sure that you put in the toner cartridge correctly or it may separate from the drum unit.

- 8 Put the drum unit and toner cartridge assembly back into the machine.

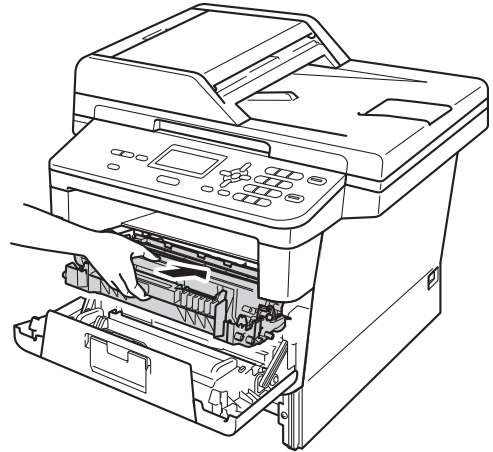

- 9 Close the front cover of the machine.
- 10 Put the paper tray firmly back in the machine.

 **Note**

If you turn off the machine while **Jam Inside** is displayed, the machine will print incomplete data from your computer. Before you turn on the machine, delete the job from the print spooler on your computer.

Paper is jammed in the duplex tray

If the LCD shows **Jam Duplex**, follow these steps:

- 1 Leave the machine turned on for 10 minutes for the internal fan to cool the extremely hot parts inside the machine.
- 2 Pull the paper tray completely out of the machine.

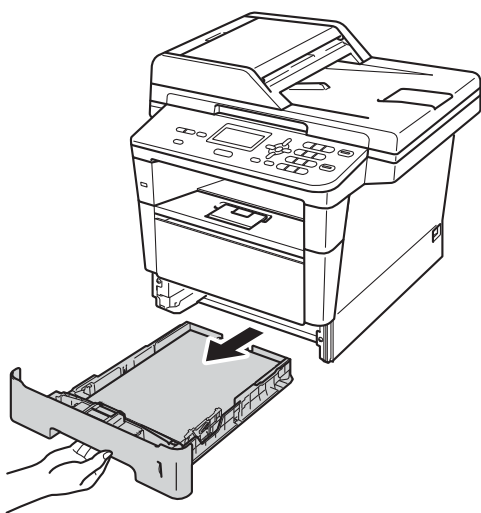

- 3 Open the back cover.

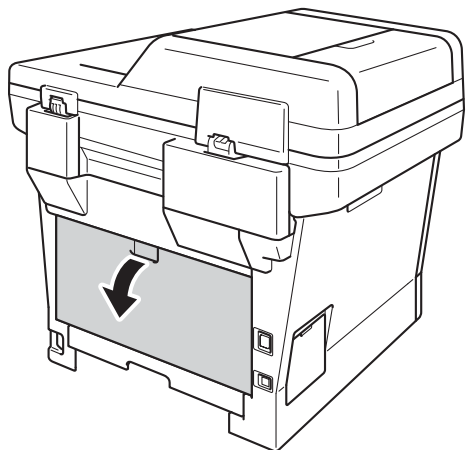

WARNING

HOT SURFACE

After you have just used the machine, some internal parts of the machine will be extremely hot. Wait for the machine to cool down before you touch the internal parts of the machine.

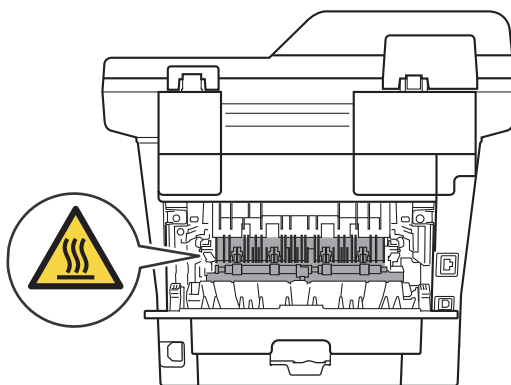

- 4 Using both hands, gently pull the jammed paper out of the back of the machine.

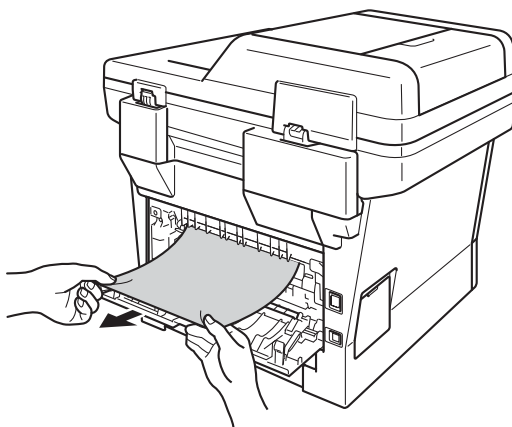

- 5 Close the back cover.

- 6 Pull the duplex tray completely out of the machine.

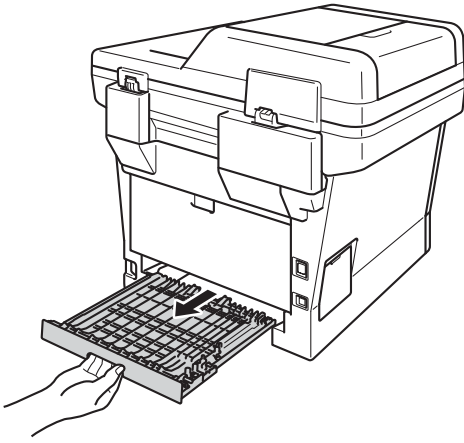

- 7 Pull the jammed paper out of the machine or out of the duplex tray.

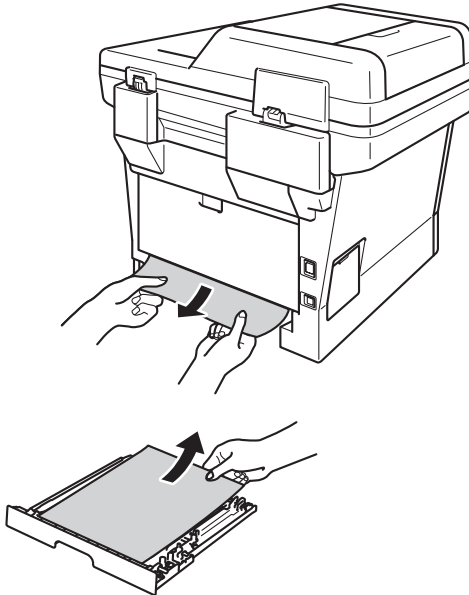

- 8 Make sure that the jammed paper does not remain under the machine from static electricity.

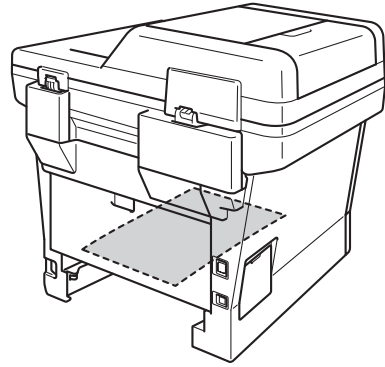

- 9 Put the duplex tray back in the machine.

- 10 Put the paper tray firmly back in the machine.

If you are having difficulty with your machine

In USA:

Please go to the Brother Solutions Center at <http://solutions.brother.com/> and click Manuals on your model page to download the other manuals.



! Important

- For technical help, you must call the country where you bought the machine. Calls must be made from within that country.
- If you think there is a problem with your machine, check the chart below and follow the troubleshooting tips. You can correct most problems by yourself.
- If you need additional help, the Brother Solutions Center offers the latest FAQs and troubleshooting tips.

Visit us at <http://solutions.brother.com/>.

- Using non-Brother supplies may affect the print quality, hardware performance, and machine reliability.

Printing difficulties

Difficulties	Suggestions
No printout.	Check that the correct printer driver has been installed and selected.
	Check to see if the LCD is showing an error message. See <i>Error and maintenance messages</i> >> page 53.
	Check that the machine is online: (Windows® 7 and Windows Server® 2008 R2) Click the  (Start) button and then Devices and Printers . Right-click Brother DCP-XXXX Printer and click See What's Printing . Click Printer and make sure Use Printer Offline is unchecked. (Windows Vista® and Windows Server® 2008) Click the  (Start) button, Control Panel, Hardware and Sound , and then Printers . Right-click Brother DCP-XXXX Printer . Make sure that Use Printer Offline is unchecked.
	(Windows® XP and Windows Server® 2003) Click the Start button and choose Printers and Faxes . Right-click Brother DCP-XXXX Printer . Make sure that Use Printer Offline is unchecked.
Contact your administrator to check your Secure Function Lock settings.	
The machine is not printing or has stopped printing.	Press Stop/Exit . The machine will cancel the print job and clear it from the memory. The printout may be incomplete.
The headers or footers appear when the document displays on the screen but they do not show up when it is printed.	There is an unprintable area on the top and bottom of the page. Adjust the top and bottom margins in your document to allow for this. See <i>Unscannable and unprintable areas</i> >> page 15.
The machine prints unexpectedly or it prints garbage.	Press Stop/Exit to cancel print jobs.
	Check the settings in your application to make sure that it is set up to work with your machine.

Printing difficulties (continued)

Difficulties	Suggestions
The machine prints the first couple of pages correctly, then some pages have text missing.	Check the settings in your application to make sure that it is set up to work with your machine.
	Your computer is not recognizing the machine's input buffer's full signal. Make sure that you connected the interface cable correctly.
	See Quick Setup Guide.
The machine does not print on both sides of the paper even though the printer driver is set for Duplex.	Check the paper size setting in the printer driver. You need to choose Letter, Legal or Folio paper that is 16 to 28 lb (60 to 105 g/m ²).
The machine does not change to Direct Print mode when a USB flash memory drive is connected to the USB direct interface.	When the machine is in Deep Sleep mode, the machine does not wake up even if you connect a USB flash memory drive to the USB direct interface. Press Stop/Exit to wake up the machine.
Cannot perform 'Page Layout' printing.	Check that the paper size setting in the application and in the printer driver are the same.
Print speed is too slow.	Try changing the printer driver setting. The highest resolution needs longer data processing, sending and printing time.
	Check that the back cover is firmly closed and the duplex tray is firmly installed.
	Add optional memory.
	See Advanced User's Guide: <i>Installing extra memory</i> .
The machine does not print from Adobe® Illustrator®.	Try to reduce the print resolution.
	See Software User's Guide: <i>Printing</i> (for Windows®).
	See Software User's Guide: <i>Printing and Faxing</i> (for Macintosh).
Poor print quality	See <i>Improving the print quality</i> ►► page 78.

Paper handling difficulties

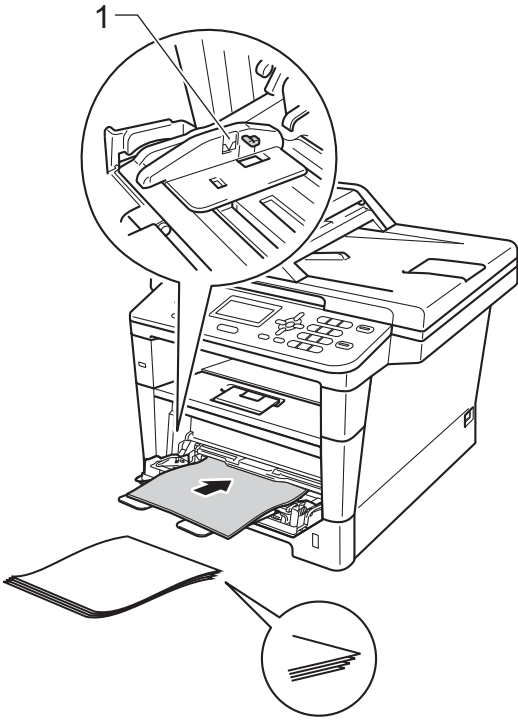
Difficulties	Suggestions
The machine does not feed paper.	<p>If the LCD shows the Paper Jam message and you still have a problem, see <i>Error and maintenance messages</i> >> page 53.</p> <p>If there is no paper, load a new stack of paper into the paper tray.</p> <p>If there is paper in the paper tray, make sure it is straight. If the paper is curled, you should straighten it. Sometimes it is helpful to remove the paper, turn the stack over and put it back into the paper tray.</p> <p>Reduce the amount of paper in the paper tray, and then try again.</p> <p>Make sure that manual feed mode is not selected in the printer driver.</p> <p>Clean the paper pick-up roller.</p> <p>See <i>Advanced User's Guide: Cleaning the paper pick-up rollers</i>.</p>
The machine does not feed paper from the MP tray.	<p>Make sure that MP Tray is selected in the printer driver.</p> <p>Fan the paper well and put it back in the tray firmly.</p>
The machine does not feed paper from the MP Tray when using a large stack of paper.	<p>Fan the paper well and make sure the paper is under the maximum paper mark (1). Stagger the pages and put them in the tray until you feel the top page touch the feed rollers as shown in the illustration.</p>  <p>The illustration shows a top-down view of the printer's MP tray. A callout circle labeled '1' points to a specific mark on the tray's surface. Below the main view, a separate callout circle shows a close-up of a paper stack where the pages are staggered, with the top edge of the top page touching the feed rollers.</p>
How do I print on envelopes?	<p>You can load envelopes in the MP tray. Your application must be set up to print the envelope size you are using. This is usually done in the Page Setup or Document Setup menu of your application. (See your application's manual for more information.)</p>

Copying difficulties

Difficulties	Suggestions
Cannot make a copy.	See <i>How to copy</i> >> page 25. Contact your administrator to check your Secure Function Lock Settings.
Vertical black line appears in copies.	Black vertical lines on copies are typically caused by dirt or correction fluid on the glass strip, or the corona wire is dirty. Clean the glass strip and scanner glass and the white bar and white plastic above them. See <i>Cleaning the corona wire</i> >> page 45. See <i>Advanced User's Guide: Cleaning the scanner</i> .
Copies are blank.	Make sure you are loading the document correctly. See <i>Using the automatic document feeder (ADF)</i> >> page 23 or <i>Using the scanner glass</i> >> page 24.

Scanning difficulties

Difficulties	Suggestions
TWAIN or WIA errors appear when starting to scan. (Windows®)	Make sure the Brother TWAIN or WIA driver is selected as the primary source in your scanning application. For example, in Nuance™ PaperPort™ 12SE, click Scan Settings, Select to choose the Brother TWAIN/WIA driver.
TWAIN or ICA errors appear when starting to scan. (Macintosh)	Make sure the Brother TWAIN driver is selected as the primary source. In PageManager, click File, Select Source and choose the Brother TWAIN driver. Mac OS X 10.6.x – 10.7.x users can also scan documents using the ICA Scanner Driver See <i>Software User's Guide: Scanning a document using the ICA driver (Mac OS X 10.6.x or greater)</i> .
OCR does not work.	Try increasing the scanning resolution. (Macintosh users) Make sure you have downloaded and installed Presto! PageManager from http://nj.newsoft.com.tw/download/brother/PM9SEInstaller_BR_multilang.dmg
Network scanning does not work.	See <i>Network difficulties</i> >> page 76.
Cannot scan.	Contact your administrator to check your Secure Function Lock Settings.

Software difficulties



Difficulties	Suggestions
Cannot install software or print.	(Windows® only) Run the Repair MFL-Pro Suite program on the CD-ROM. This program will repair and reinstall the software.

B

Network difficulties

Difficulties	Suggestions
Cannot print over a wired Network.	<p>If you are having Network problems.</p> <p>See Network User's Guide.</p> <p>Make sure your machine is powered on and is online and in Ready mode. Print the Network Configuration Report to verify your Network settings are correct.</p> <p>See Advanced User's Guide: <i>Network Configuration Report</i>.</p> <p>Reconnect the LAN cable to the hub to verify that the cable and network connections are good. If possible, try connecting the machine to a different port on your hub using a different cable. You can check the current wired network status from the Network control panel menu.</p>
The network scanning feature does not work.	<p>(Windows® and Macintosh)</p> <p>The network scanning feature may not work due to your firewall settings. Change or disable the firewall settings. It is necessary to set the third-party Security/Firewall Software to allow Network scanning. To add port 54925 for Network scanning, enter the information below:</p> <ul style="list-style-type: none"> ■ In Name: Enter any description, for example Brother NetScan. ■ In Port number: Enter 54925. ■ In Protocol: UDP is selected. <p>Please refer to the instruction manual that came with your third-party Security/Firewall Software or contact the software manufacturer.</p> <p>For more details, you can read FAQs and troubleshooting suggestions at http://solutions.brother.com/.</p> <p>(Macintosh)</p> <p>Re-select your machine in the Device Selector application located in Macintosh HD/Library/Printers/Brother/Utilities/DeviceSelector or from the model list in ControlCenter2.</p>
The Brother software cannot be installed.	<p>(Windows®)</p> <p>If the Security Software warning appears on the PC screen during the installation, change the Security Software settings to permit the Brother product setup program or other programs to run.</p> <p>(Macintosh)</p> <p>If you are using a firewall function of anti-spyware or antivirus security software, temporarily disable it and then install the Brother software.</p>

Other difficulties

Difficulties	Suggestions
<p>The machine will not turn on.</p>	<p>Adverse conditions on the power connection (such as lightning or a power surge) may have triggered the machine's internal safety mechanisms. Turn the machine off and unplug the power cord. Wait for ten minutes, then plug in the power cord and turn the machine on.</p> <p>If the problem is not solved, turn off the machine. If you are using a backup battery or surge suppressor device, disconnect it to make sure it is not the problem. Plug the machine's power cord directly into a different known working wall outlet and turn on the machine.</p>
<p>The machine cannot print EPS data that includes binary with the BR-Script3 printer driver.</p>	<p>(Windows®) You need the following settings to print EPS data:</p> <ol style="list-style-type: none"> 1 For Windows® 7 and Windows Server® 2008 R2: Click the  (Start) button and then Devices and Printers. For Windows Vista® and Windows Server® 2008: Click the  (Start) button, Control Panel, Hardware and Sound, and then Printers. For Windows® XP and Windows Server® 2003: Click the Start button, and select Printers and Faxes. 2 Right-click the Brother DCP-XXXX BR-Script3 icon and select Properties¹. 3 From the Device Settings tab, choose TBCP (Tagged binary communication protocol) in Output Protocol. <p>(Macintosh) If your machine is connected to a computer with a USB interface, you cannot print EPS data that includes binary. You can print EPS data at the machine via a network. To install the BR-Script3 printer driver over the network, visit the Brother Solutions Center at http://solutions.brother.com/.</p>

¹ For Windows® 7 and Windows Server® 2008 R2:
Printer properties, and **Brother DCP-XXXX BR-Script3** if necessary

Improving the print quality

If you have a print quality problem, print a test page first (**Menu, 3, 2, 3**). If the printout looks good, the problem is probably not the machine. Check the interface cable connections and try printing a different document. If the printout or test page printed from the machine has a quality problem, check the following steps first. And then, if you still have a print quality problem, check the chart below and follow the recommendations.





Note

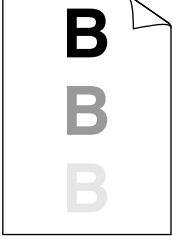

Using non-Brother supplies may affect the print quality, hardware performance, and machine reliability.

- 1 To get the best print quality, we suggest using the recommended paper. Check that you use paper that meets our specifications. (See *Acceptable paper and other print media* >> page 18.)
- 2 Check that the drum unit and toner cartridge are installed correctly.

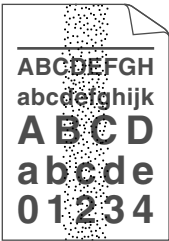

Examples of poor print quality	Recommendation
 <p style="text-align: center;">Faint</p>	<ul style="list-style-type: none"> ■ Take out the drum unit and toner cartridge assembly. Hold the assembly level with both hands and gently shake it from side to side several times to spread the toner evenly inside the cartridge. ■ If the LCD shows <code>Replace Toner</code>, put in a new toner cartridge. See <i>Replacing the toner cartridge</i> >> page 39. ■ Check the machine's environment. Conditions such as humidity, high temperatures, and so on, may cause this print fault. See Product Safety Guide: <i>Choosing a location</i>. ■ If the whole page is too light, <code>Toner Save</code> may be turned on. Turn off <code>Toner Save</code> in the machine's menu settings or Toner Save Mode in the Printer Properties of the driver. See Advanced User's Guide: <i>Toner Save</i>. See Software User's Guide: <i>Printing</i> (for Windows®). See Software User's Guide: <i>Printing and Faxing</i> (for Macintosh). ■ Clean the corona wire of the drum unit. See <i>Cleaning the corona wire</i> >> page 45. ■ Put in a new toner cartridge. See <i>Replacing the toner cartridge</i> >> page 39. ■ Put in a new drum unit. See <i>Replacing the drum unit</i> >> page 47.

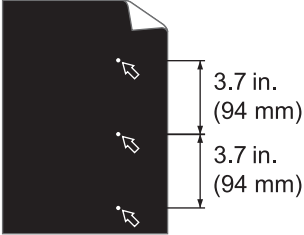
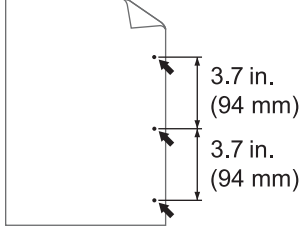
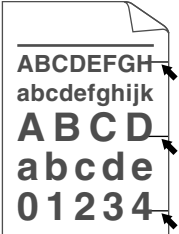

Examples of poor print quality	Recommendation
 <p data-bbox="211 556 408 587">Gray background</p>	<ul style="list-style-type: none"> <li data-bbox="504 293 1168 363">■ Make sure that you use paper that meets our specifications. See <i>Acceptable paper and other print media</i> >> page 18. <li data-bbox="504 382 1168 506">■ Check the machine's environment. Conditions such as high temperatures and high humidity can increase the amount of background shading. See Product Safety Guide: <i>Choosing a location</i>. <li data-bbox="504 525 1031 595">■ Put in a new toner cartridge. See <i>Replacing the toner cartridge</i> >> page 39. <li data-bbox="504 614 976 683">■ Put in a new drum unit. See <i>Replacing the drum unit</i> >> page 47.
 <p data-bbox="257 954 362 985">Ghosting</p>	<ul style="list-style-type: none"> <li data-bbox="504 691 1251 788">■ Make sure that you use paper that meets our specifications. Rough-surfaced paper or thick paper may cause this problem. See <i>Acceptable paper and other print media</i> >> page 18. <li data-bbox="504 807 1251 950">■ Make sure that you choose the appropriate media type in the printer driver or in the machine's <i>Paper Type</i> menu setting. See <i>Paper Type</i> >> page 16. See Software User's Guide: <i>Printing</i> (for Windows®). See Software User's Guide: <i>Printing and Faxing</i> (for Macintosh). <li data-bbox="504 1008 1218 1124">■ Choose Reduce Ghosting mode in the printer driver. See Software User's Guide: <i>Printing</i> (for Windows®). See Software User's Guide: <i>Printing and Faxing</i> (for Macintosh). <li data-bbox="504 1143 976 1213">■ Put in a new drum unit. See <i>Replacing the drum unit</i> >> page 47. <li data-bbox="504 1232 1031 1302">■ Put in a new toner cartridge. See <i>Replacing the toner cartridge</i> >> page 39. <li data-bbox="504 1321 1004 1462">■ The fuser unit may be contaminated. Call Brother Customer Service at: In USA: 1-877-BROTHER (1-877-276-8437) In Canada: 1-877-BROTHER

Examples of poor print quality	Recommendation
 <p data-bbox="200 556 360 581">Toner specks</p>	<ul style="list-style-type: none"> <li data-bbox="477 291 1218 392">■ Make sure that you use paper that meets our specifications. Rough-surfaced paper may cause the problem. See <i>Acceptable paper and other print media</i> >> page 18. <li data-bbox="477 407 957 475">■ Clean the corona wire of the drum unit. See <i>Cleaning the corona wire</i> >> page 45. <li data-bbox="477 490 1098 558">■ The drum unit may be damaged. Put in a new drum unit. See <i>Replacing the drum unit</i> >> page 47. <li data-bbox="477 573 975 726">■ The fuser unit may be contaminated. Call Brother Customer Service at: In USA: 1-877-BROTHER (1-877-276-8437) In Canada: 1-877-BROTHER
 <p data-bbox="207 1010 349 1035">Hollow print</p>	<ul style="list-style-type: none"> <li data-bbox="477 741 1136 809">■ Make sure that you use paper that meets our specifications. See <i>Acceptable paper and other print media</i> >> page 18. <li data-bbox="477 824 1218 954">■ Choose Thick Paper mode in the printer driver, choose Thick in the machine's Paper Type menu setting or use thinner paper than you are currently using. See <i>Paper Type</i> >> page 16. See <i>Software User's Guide: Printing</i> (for Windows®). See <i>Software User's Guide: Printing and Faxing</i> (for Macintosh). <li data-bbox="477 969 1218 1157">■ Check the machine's environment. Conditions such as high humidity can cause hollow print. See <i>Product Safety Guide: Choosing a location</i>. <li data-bbox="477 1172 1098 1240">■ The drum unit may be damaged. Put in a new drum unit. See <i>Replacing the drum unit</i> >> page 47.
 <p data-bbox="227 1522 329 1547">All black</p>	<ul style="list-style-type: none"> <li data-bbox="477 1257 1218 1358">■ Clean the corona wire inside the drum unit by sliding the green tab. Be sure to return the green tab to the home position (▲). See <i>Cleaning the corona wire</i> >> page 45. <li data-bbox="477 1373 1098 1441">■ The drum unit may be damaged. Put in a new drum unit. See <i>Replacing the drum unit</i> >> page 47.

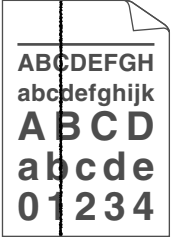
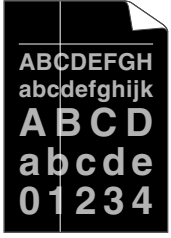
Examples of poor print quality	Recommendation
 <p>White lines across the page</p>	<ul style="list-style-type: none"> ■ Make sure that you use paper that meets our specifications. A rough surfaced paper or thick print media can cause this problem. See <i>Acceptable paper and other print media</i> >> page 18. ■ Make sure that you choose the appropriate media type in the printer driver or in the machine's <i>Paper Type</i> menu setting. See <i>Paper Type</i> >> page 16. See <i>Software User's Guide: Printing</i> (for Windows®). See <i>Software User's Guide: Printing and Faxing</i> (for Macintosh). ■ The problem may disappear by itself. Print multiple pages to clear this problem, especially if the machine has not been used for a long time. ■ The drum unit may be damaged. Put in a new drum unit. See <i>Replacing the drum unit</i> >> page 47.
 <p>Lines across the page</p>	<ul style="list-style-type: none"> ■ Clean the corona wire inside the drum unit. See <i>Cleaning the corona wire</i> >> page 45. ■ The drum unit may be damaged. Put in a new drum unit. See <i>Replacing the drum unit</i> >> page 47.
 <p>White lines, bands or ribbing across the page</p>	<ul style="list-style-type: none"> ■ Check the machine's environment. Conditions such as high humidity and high temperatures may cause this print quality problem. See <i>Product Safety Guide: Choosing a location</i>. ■ If the problem is not solved after printing a few pages, put in a new drum unit. See <i>Replacing the drum unit</i> >> page 47.

Examples of poor print quality	Recommendation
 <p>White Spots on black text and graphics at 3.7 in. (94 mm) intervals</p>  <p>Black Spots at 3.7 in. (94 mm) intervals</p>	<ul style="list-style-type: none"> ■ Make 10-15 copies of a blank, white sheet of paper. If the problem is not solved after printing the blank pages, the drum unit may have foreign material, such as glue from a label, stuck on the drum. Clean the drum unit. See <i>Advanced User's Guide: Cleaning the drum unit</i>. ■ The drum unit may be damaged. Put in a new drum unit. See <i>Replacing the drum unit</i> >> page 47.
 <p>Black toner marks across the page</p>	<ul style="list-style-type: none"> ■ If you use label sheets for laser printers, the glue from the sheets may sometimes stick to the OPC drum surface. Clean the drum unit. See <i>Advanced User's Guide: Cleaning the drum unit</i>. ■ Make sure that you use paper that meets our specifications. See <i>Acceptable paper and other print media</i> >> page 18. ■ Do not use paper that has clips or staples because they will scratch the surface of the drum. ■ If the unpacked drum unit is in direct sunlight or room light, the unit may be damaged. ■ The toner cartridge may be damaged. Put in a new toner cartridge. See <i>Replacing the toner cartridge</i> >> page 39. ■ The drum unit may be damaged. Put in a new drum unit. See <i>Replacing the drum unit</i> >> page 47.

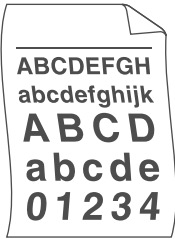
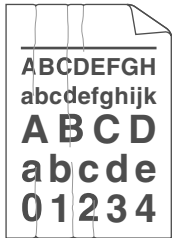
Examples of poor print quality	Recommendation
 <p>Black lines down the page Printed pages have toner stains down the page</p>	<ul style="list-style-type: none"> ■ Clean the corona wire inside the drum unit by sliding the green tab. See <i>Cleaning the corona wire</i> >> page 45. ■ Make sure the green tab of the corona wire is at the home position (▲). ■ The toner cartridge may be damaged. Put in a new toner cartridge. See <i>Replacing the toner cartridge</i> >> page 39. ■ The drum unit may be damaged. Put in a new drum unit. See <i>Replacing the drum unit</i> >> page 47. ■ The fuser unit may be contaminated. Call Brother Customer Service at: In USA: 1-877-BROTHER (1-877-276-8437) In Canada: 1-877-BROTHER
 <p>White lines down the page</p>	<ul style="list-style-type: none"> ■ Make sure that foreign material such as a torn piece of paper, sticky notes or dust is not inside the machine and around the drum unit and toner cartridge. ■ The toner cartridge may be damaged. Put in a new toner cartridge. See <i>Replacing the toner cartridge</i> >> page 39. ■ The drum unit may be damaged. Put in a new drum unit. See <i>Replacing the drum unit</i> >> page 47.
 <p>Image skewed</p>	<ul style="list-style-type: none"> ■ Make sure that the paper or other print media is loaded correctly in the paper tray and that the guides are not too tight or too loose against the paper stack. ■ Set the paper guides correctly. See <i>Loading paper and print media</i> >> page 9. ■ If you are using the MP tray, see <i>Loading paper in the multi-purpose tray (MP tray)</i> >> page 11. ■ The paper tray may be too full. See <i>Loading paper and print media</i> >> page 9. ■ Check the paper type and quality. See <i>Acceptable paper and other print media</i> >> page 18. ■ Check for loose objects such as torn paper inside the machine. ■ If the problem only occurs during duplex printing, check for torn paper in the duplex tray, verify that the duplex tray is inserted completely and verify that the back cover is closed completely.

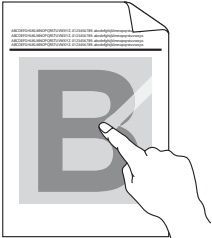
Examples of poor print quality	Recommendation
 <p data-bbox="193 552 367 581">Curled or wavy</p>	<ul style="list-style-type: none"> <li data-bbox="477 291 1163 349">■ Check the paper type and quality. High temperatures and high humidity will cause paper to curl. See <i>Acceptable paper and other print media</i> >> page 18. See Product Safety Guide: <i>Choosing a location</i>. <li data-bbox="477 450 1222 562">■ If you do not use the machine often, the paper may have been in the paper tray too long. Turn over the stack of paper in the paper tray. Also, fan the paper stack and then rotate the paper 180° in the paper tray. <li data-bbox="477 581 1222 633">■ Open the back cover (face-up output tray) to let the printed paper exit onto the face-up output tray. <li data-bbox="477 653 1222 705">■ Choose Reduce Paper Curl mode in the printer driver when you do not use our recommended paper. See Software User's Guide: <i>Printing</i> (for Windows®). See Software User's Guide: <i>Printing and Faxing</i> (for Macintosh).
 <p data-bbox="161 1070 397 1099">Wrinkles or creases</p>	<ul style="list-style-type: none"> <li data-bbox="477 813 1002 884">■ Make sure that paper is loaded correctly. See <i>Loading paper and print media</i> >> page 9. <li data-bbox="477 894 1112 966">■ Check the paper type and quality. See <i>Acceptable paper and other print media</i> >> page 18. <li data-bbox="477 975 1222 1039">■ Turn over the stack of paper in the tray or rotate the paper 180° in the input tray.
 <p data-bbox="175 1335 385 1363">Envelope Creases</p>	<ul style="list-style-type: none"> <li data-bbox="477 1112 1218 1164">■ Make sure that envelopes are printed with the back cover (face-up output tray) opened. See <i>Printing on thick paper, labels and envelopes from the MP tray</i> >> page 13. <li data-bbox="477 1251 1112 1323">■ Check the envelope type and quality. See <i>Acceptable paper and other print media</i> >> page 18. <li data-bbox="477 1333 1218 1404">■ Make sure envelopes are fed only from the MP tray. See <i>Loading paper in the multi-purpose tray (MP tray)</i> >> page 11.
 <p data-bbox="216 1682 344 1711">Poor fixing</p>	<ul style="list-style-type: none"> <li data-bbox="477 1421 1112 1493">■ Choose Improve Toner Fixing mode in the printer driver. See Software User's Guide: <i>Printing</i> (for Windows®). See Software User's Guide: <i>Printing and Faxing</i> (for Macintosh). <li data-bbox="502 1551 1208 1615">If this selection does not provide enough improvement, change the printer driver setting in Media Type to a thick setting.

Examples of poor print quality	Recommendation
 <p data-bbox="271 566 348 591">Curled</p>	<ul style="list-style-type: none"> <li data-bbox="504 295 1116 320">■ Choose Reduce Paper Curl mode in the printer driver. <li data-bbox="532 343 1089 369">See Software User's Guide: <i>Printing</i> (for Windows®). <li data-bbox="532 388 1212 413">See Software User's Guide: <i>Printing and Faxing</i> (for Macintosh). <li data-bbox="504 432 1254 484">■ Open the back cover (face-up output tray) to let the printed paper exit onto the face-up output tray.

Machine Information

Checking the Serial Number

You can see the machine's Serial Number on the LCD.

- 1 Press **Menu**, **6**, **2**.

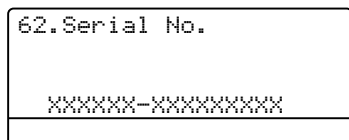

- 2 Press **Stop/Exit**.

Reset functions

The following reset functions are available:

1 Network

You can reset the internal print server back to its default factory settings such as the password and IP address information.

2 All Settings

You can reset all the machine's settings back to the settings that were set at the factory.

Brother strongly recommends you perform this operation when you dispose of the machine.



Note

Unplug the interface cable before you choose **Network** or **All Settings**.

How to reset the machine

- 1 Press **Menu**, **1**, **9**.

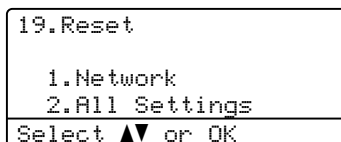

- 2 Press **▲** or **▼** to choose the reset function you want to use. Press **OK**.

- 3 Do one of the following;
 - To reset the settings, press **1** and go to step 4.
 - To exit without making changes, press **2** and go to step 5.

- 4 You will be asked to reset the machine. Do one of the following;

- To reset the machine press **1**. The machine will begin the reset.
- To exit without resetting the machine, press **2**. Go to step 5.

- 5 Press **Stop/Exit**.



Note

You can also reset the Network settings by pressing **Menu**, **5**, **0**.

On-screen programming

Your machine has been designed to be easy to use. The LCD provides on-screen programming using the menu keys.

We have created step by step on-screen instructions to help you program your machine. Simply follow the steps as they guide you through the menu selections and programming options.

How to access the menu mode

- 1 Press **Menu**.
- 2 Choose an option.
 - Press **1** for General Setup menu.
 - Press **2** for Copy menu.
 - Press **3** for Printer menu.
 - Press **4** for USB Direct I/F menu.
 - Press **5** for Network menu.
 - Press **6** for Machine Info. menu.

You can also scroll through each menu level by pressing **▲** or **▼** for the direction you want.

- 3 Press **OK** when the option you want appears on the LCD.
The LCD will then show the next menu level.
- 4 Press **▲** or **▼** to scroll to your next menu selection.
- 5 Press **OK**.
When you have finished setting an option, the LCD will show *Accepted*.
- 6 Press **Stop/Exit** to exit Menu mode.

Menu table

The factory settings are shown in Bold with an asterisk.

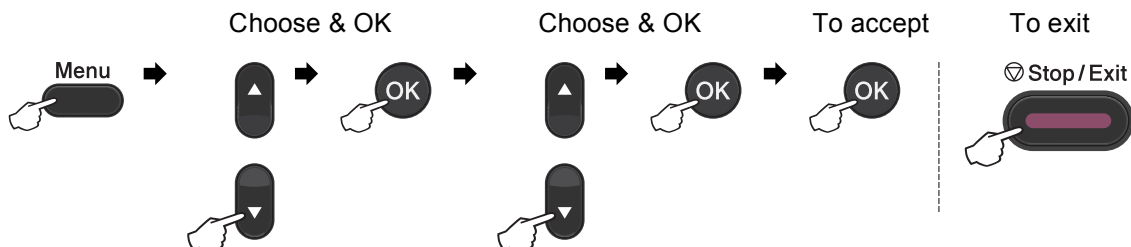

Level 1	Level 2	Level 3	Level 4	Options	Descriptions	Page
1.General Setup	1.Paper	1.Paper Type	1.MP Tray	Thin Plain* Thick Thicker Recycled Paper Label	Sets the type of paper in the paper tray.	16
			2.Tray#1	Thin Plain* Thick Thicker Recycled Paper	Sets the type of paper in the paper tray.	16
			3.Tray#2 (This menu appears if you have installed the optional lower tray on DCP-8150DN or DCP-8155DN.)	Thin Plain* Thick Thicker Recycled Paper	Sets the type of paper in the paper tray.	16
<p>◆ See <i>Advanced User's Guide</i>.</p> <p>‡ See <i>Quick Setup Guide</i>.</p> <p>□ See <i>Software User's Guide</i>.</p>						
<p> The factory settings are shown in Bold with an asterisk.</p>						

Level 1	Level 2	Level 3	Level 4	Options	Descriptions	Page
1.General Setup (Continued)	1.Paper (Continued)	2.Paper Size	1.MP Tray	A4 Letter* Legal Executive A5 A5 L A6 B5 B6 Folio Any	Sets the size of the paper in the paper tray.	16
			2.Tray#1	A4 Letter* Legal Executive A5 A5 L A6 B5 B6 Folio	Sets the size of the paper in the paper tray.	16
			3.Tray#2 (This menu appears if you have installed the optional lower tray on DCP-8150DN or DCP-8155DN.)	A4 Letter* Legal Executive A5 B5 B6 Folio	Sets the size of the paper in the paper tray.	16
	2.Beeper	—	—	Low Med* High Off	Adjusts the volume level of the beeper.	See ♦.
<p>♦ See <i>Advanced User's Guide</i>.</p> <p>‡ See <i>Quick Setup Guide</i>.</p> <p>□ See <i>Software User's Guide</i>.</p>						
<p> The factory settings are shown in Bold with an asterisk.</p>						

Level 1	Level 2	Level 3	Level 4	Options	Descriptions	Page
1.General Setup (Continued)	3.Ecology	1.Toner Save	—	On Off*	Increases the page yield of the toner cartridge.	See ◆.
		2.Sleep Time	—	Range varies depending on models. 03Min*	Conserves power.	
		4.Quiet Mode	—	—	On Off*	
	5.Tray Use	1.Copy	—	Tray#1 Only Tray#2 Only MP Only MP>T1>T2* T1>T2>MP (Tray#2 and T2 appear if you have installed the optional lower tray on DCP-8150DN or DCP-8155DN.)	Chooses the tray that will be used for COPY mode.	17
		2.Print	—	Tray#1 Only Tray#2 Only MP Only MP>T1>T2* T1>T2>MP (Tray#2 and T2 appear if you have installed the optional lower tray on DCP-8150DN or DCP-8155DN.)	Chooses the tray that will be used for Print mode.	17
	6.LCD Contrast	—	—	-□□□■+ -□□□■+ -□□■□+* -■□□□+ -■□□□+	Adjusts the contrast of the LCD.	See ◆.

◆ See *Advanced User's Guide*.

‡ See *Quick Setup Guide*.

□ See *Software User's Guide*.





The factory settings are shown in Bold with an asterisk.

Level 1	Level 2	Level 3	Level 4	Options	Descriptions	Page
1.General Setup (Continued)	7.Security	1.Function Lock	—	—	Can restrict selected machine operations for up to 25 individual users and all other non-authorized Public users.	See ◆.
		2.Setting Lock	—	—	Stops unauthorized users from changing the machine's current settings.	
	8.Document Scan	1.Glass ScanSize	—	A4 Letter* Legal/Folio (Legal/Folio is available for DCP-8150DN and DCP-8155DN)	Adjusts the scan area of the scanner glass to the size of the document.	See □.
		2.File Size	1.Color	Small Medium* Large	You can set your own default settings for the data compression ratio.	
			2.Gray	Small Medium* Large		
	3.Duplex Scan (DCP-8155DN)	—	Long edge* Short edge	Chooses the duplex scanning format.	See ◆.	
	9.Reset	1.Network	—	1.Reset 2.Exit	Restores all network settings to factory default.	86
		2.All Settings	—	1.Reset 2.Exit	Restores all the machine settings to factory default.	
	0.Local Language	—	—	(in USA) English* Español	Allows you to change the LCD language for your country.	See ‡.
	◆ See <i>Advanced User's Guide</i> .					
‡ See <i>Quick Setup Guide</i> .						
□ See <i>Software User's Guide</i> .						
 The factory settings are shown in Bold with an asterisk.						

Level 1	Level 2	Level 3	Options	Descriptions	Page
2. Copy	1. Quality	—	Auto* Text Photo Graph	You can choose the Copy resolution for your type of document.	See ◆.
	2. Brightness	—	-□□□■+ -□□□■+ -□□■□+* -□■□□+ -■□□□+	Adjust the brightness for copies.	
	3. Contrast	—	-□□□■+ -□□□■+ -□□■□+* -□■□□+ -■□□□+	Adjusts the contrast for copies.	
◆ See <i>Advanced User's Guide</i> .					
 The factory settings are shown in Bold with an asterisk.					

Level 1	Level 2	Level 3	Options	Descriptions	Page
3. Printer	1. Emulation	—	Auto (EPSON) * Auto (IBM) HP LaserJet BR-Script 3 Epson FX-850 IBM Proprinter	Chooses the emulation mode.	See <input type="checkbox"/> .
	2. Print Options	1. Internal Font	1. HP LaserJet 2. BR-Script 3	Prints a list of the machine's internal fonts.	
		2. Configuration	—	Prints a list of the machine's printer settings.	
		3. Test Print	—	Prints a test page.	
	3. Duplex	—	On (Long Edge) On (Short Edge) off*	Enables or disables duplex printing. You can also choose long edge or short edge duplex printing.	
	4. Auto Continue	—	On* Off	If this setting is enabled the machine will automatically clear a paper size error, and will use any compatible paper from the other paper trays.	
5. Reset Printer	—	1. Reset 2. Exit	Restores the printer settings to the original factory default settings.		
<input type="checkbox"/> See <i>Software User's Guide</i> .					
 The factory settings are shown in Bold with an asterisk.					

Level 1	Level 2	Level 3	Options	Descriptions	Page
4.USB Direct I/F	1.Direct Print	1.Paper Size	A4 Letter* Legal Executive A5 A5 L A6 B5 B6 Folio	Sets the paper size when printing directly from the USB flash memory drive.	26
		2.Media Type	Thin Plain* Thick Thicker Recycled Paper Label	Sets the media type when printing directly from the USB flash memory drive.	26
		3.Multiple Page	1in1* 2in1 4in1 9in1 16in1 25in1 1 in 2x2 pages 1 in 3x3 pages 1 in 4x4 pages 1 in 5x5 pages	Sets the page style when printing multiple pages directly from the USB Flash memory drive.	27
		4.Orientation	Portrait* Landscape	Sets the page orientation when printing directly from the USB Flash memory drive.	27
		5.Collate	On* Off	Enables or disables the page collation when printing directly from the USB Flash memory drive.	27
<input type="checkbox"/> See <i>Software User's Guide</i> .					
 The factory settings are shown in Bold with an asterisk.					

Level 1	Level 2	Level 3	Options	Descriptions	Page
4.USB Direct I/F (Continued)	1.Direct Print (Continued)	6.Print Quality	Normal* Fine	Sets the print quality option when printing directly from the USB Flash memory drive.	27
		7.PDF Option	Document* Document&Markup Document&Stamps	Sets the PDF option whether to print comments (Markup) or stamps in the PDF file along with the text.	27
		8.Index Print	Simple* Details	Sets the index print option, simple format or details.	27
	2.Scan to USB	1.Resolution	Color 100 dpi* Color 200 dpi Color 300 dpi Color 600 dpi Color Auto Gray 100 dpi Gray 200 dpi Gray 300 dpi Gray Auto B&W 300 dpi B&W 200 dpi B&W 200x100 dpi	Sets the resolution to send the scanned data to USB Flash memory drive.	See <input type="checkbox"/> .
		2.File Name	—	Enter the file name of the scanned data.	
<input type="checkbox"/> See <i>Software User's Guide</i> .					
 The factory settings are shown in Bold with an asterisk.					

Level 1	Level 2	Level 3	Level 4	Options	Descriptions	Page
5. Network	1. TCP/IP	1. Boot Method	—	Auto* Static RARP BOOTP DHCP	Chooses the BOOT method that best suits your needs.	See + .
		(IP Boot Tries)	—	00003* [00000-32767]	Specifies the number of attempts the machine will try to obtain an IP address when the Boot Method is set to any setting except Static .	
		2. IP Address	—	[000-255]. [000-255]. [000-255]. [000-255]	Enter the IP address.	
		3. Subnet Mask	—	[000-255]. [000-255]. [000-255]. [000-255]	Enter the Subnet mask.	
		4. Gateway	—	[000-255]. [000-255]. [000-255]. [000-255]	Enter the Gateway address.	
		5. Node Name	—	BRNXXXXXXXXXXXX	Enter the Node name. (Up to 32 characters)	
		6. WINS Config	—	Auto* Static	Chooses the WINS configuration mode.	
7. WINS Server	—	Primary [000-255]. [000-255]. [000-255]. [000-255] Secondary [000-255]. [000-255]. [000-255]. [000-255]	Specifies the IP address of the primary or secondary WINS server.			

+ See *Network User's Guide*.



The factory settings are shown in **Bold** with an asterisk.

Level 1	Level 2	Level 3	Level 4	Options	Descriptions	Page
5. Network (Continued)	1. TCP/IP (Continued)	8. DNS Server	—	Primary [000-255]. [000-255]. [000-255]. [000-255] Secondary [000-255]. [000-255]. [000-255]. [000-255]	Specifies the IP address of the primary or secondary DNS server.	See +.
		9. APIPA	—	On* Off	Automatically allocates the IP address from the link-local address range.	
		0. IPv6	—	On Off*	Enable or Disable the IPv6 protocol. If you want to use the IPv6 protocol, visit http://solutions.brother.com/ for more information.	
	2. Ethernet	—	—	Auto* 100B-FD 100B-HD 10B-FD 10B-HD	Chooses the Ethernet link mode.	
	3. Status	—	—	Active 100B-FD Active 100B-HD Active 10B-FD Active 10B-HD Inactive	Shows the Ethernet link status.	
4. MAC Address	—	—	—	Shows the MAC address of the machine.		
+ See <i>Network User's Guide</i> .						
 The factory settings are shown in Bold with an asterisk.						

Level 1	Level 2	Level 3	Level 4	Options	Descriptions	Page
5.Network (Continued)	5.Scan To FTP	—	—	Color 100 dpi* Color 200 dpi Color 300 dpi Color 600 dpi Color Auto Gray 100 dpi Gray 200 dpi Gray 300 dpi Gray Auto B&W 300 dpi B&W 200 dpi B&W 200x100 dpi	Chooses the file format to send the scanned data via FTP.	See +.
	6.ScanTo Network (Windows®)	—	—	Color 100 dpi* Color 200 dpi Color 300 dpi Color 600 dpi Color Auto Gray 100 dpi Gray 200 dpi Gray 300 dpi Gray Auto B&W 300 dpi B&W 200 dpi B&W 200x100 dpi	You can scan a black and white or color document directly to a CIFS server on your local network or on the Internet.	
	0.Network Reset	—	—	1.Reset 2.Exit	Restore all network settings to the factory defaults.	

+ See *Network User's Guide*.



The factory settings are shown in Bold with an asterisk.

Level 1	Level 2	Level 3	Options	Descriptions	Page
6. Machine Info.	1. Date&Time	1. Date&Time	—	Puts the date and time on the LCD.	See ‡.
		2. Auto Daylight	On Off*	Changes for Daylight Saving Time automatically.	See ◆.
		3. Time Zone	UTCXXX:XX	Sets the time zone for your country.	See †.
	2. Serial No.	—	—	You can check the serial number of your machine.	86
	3. Page Counter	—	Total List Copy Print	You can check the number of total pages the machine has printed during its life.	See ◆.
	4. User Settings	—	—	Lists your settings.	
	5. Network Config	—	—	Lists your Network settings.	
	6. Drum Dot Print	—	—	Prints the drum dot check sheet.	
	7. Parts Life	1. Drum	—	You can check the percentage of a machine part's life that remains available. (PF Kit 2 appears only if you installed the optional paper tray on DCP-8150DN or DCP-8155DN.)	
		2. Fuser	—		
		3. Laser	—		
		4. PF Kit MP	—		
		5. PF Kit 1	—		
6. PF Kit 2		—			
◆ See <i>Advanced User's Guide</i> .					
‡ See <i>Quick Setup Guide</i> .					
† See <i>Network User's Guide</i> .					
 The factory settings are shown in Bold with an asterisk.					

Entering text

When setting certain menu selections, you will need to type text characters. The numeric keys have letters printed on them. The keys: **0**, **#** and ***** do *not* have printed letters because they are used for special characters.

Press the appropriate numeric key the number of times shown in this reference table to access the character you want.

Press Key	one time	two times	three times	four times	five times	six times	seven times	eight times	nine times
1	@	.	/	1	@	.	/	1	@
2	a	b	c	A	B	C	2	a	b
3	d	e	f	D	E	F	3	d	e
4	g	h	i	G	H	I	4	g	h
5	j	k	l	J	K	L	5	j	k
6	m	n	o	M	N	O	6	m	n
7	p	q	r	s	P	Q	R	S	7
8	t	u	v	T	U	V	8	t	u
9	w	x	y	z	W	X	Y	Z	9

For menu selections that do not allow lower case letter selection, please use this reference table.

Press Key	one time	two times	three times	four times	five times
2	A	B	C	2	A
3	D	E	F	3	D
4	G	H	I	4	G
5	J	K	L	5	J
6	M	N	O	6	M
7	P	Q	R	7	P
8	T	U	V	8	T
9	W	X	Y	9	W

Inserting spaces

To enter a space, press **▶** twice between characters.

Making corrections

If you entered a character incorrectly and want to change it, press **◀** or **▶** to move the cursor to the incorrect character, and then press **Clear**.

Repeating letters

To enter a letter on the same key as the previous letter, press **▶** to move the cursor right before pressing the key again.

Special characters and symbols

Press *, # or 0, then press ◀ or ▶ to move the cursor to the symbol or letter you want. Press **OK** to choose it. The symbols and characters below will appear depending on your menu selection.

Press *	for	(space) ! " # \$ % & ' () * + , - . /
Press #	for	: ; < = > ? @ [] ^ _ \ ~ ' { }
Press 0	for	Á À Ã Ä Å Ç È É Ê Ë Ì Í Î Ï Ó Ô Õ Ö Ø Ù Ú Û Ü

D

Specifications

General



Note

This chapter provides a summary of the machines' specifications. For additional specifications visit us at <http://www.brother.com/> for details.

Model		DCP-8110DN	DCP-8150DN	DCP-8155DN
Printer Type		Laser		
Print Method		Electrophotographic Laser Printer		
Memory Capacity	Standard	64 MB		128 MB
	Optional	1 slot: DDR2 SO-DIMM (144-pin) up to 256 MB		
LCD (liquid crystal display)		22 characters × 5 lines		
Power Source		110 - 120 V AC 50/60 Hz		
Power Consumption ¹ (Average)	Peak	Approx. 1200 W at 77 °F (25 °C)		
	Copying	Approx. 669 W at 77 °F (25 °C)	Approx. 702 W at 77 °F (25 °C)	
	Copying (Quiet Mode)	Approx. 336 W at 77 °F (25 °C)	Approx. 350 W at 77 °F (25 °C)	
	Ready	Approx. 8.1 W at 77 °F (25 °C)		
	Deep Sleep	Approx. 1.2 W	Approx. 1.4 W	
Dimensions		DCP-8150DN, DCP-8155DN 		

¹ USB connections to PC

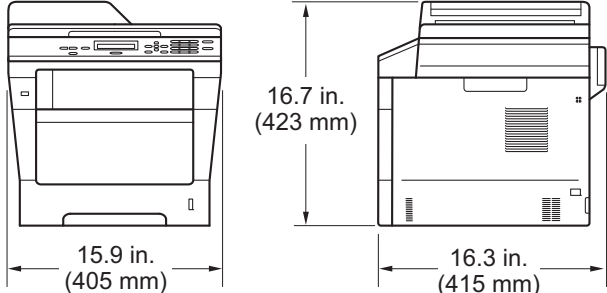
Model		DCP-8110DN	DCP-8150DN	DCP-8155DN	
Dimensions (Continued)		DCP-8110DN 			
Weights (with consumables)		34.4 lb (15.6 kg)	35.5 lb (16.1 kg)	36.4 lb (16.5 kg)	
Noise Level	Sound Pressure	Printing	LPAm = 59 dB (A)		
		Ready	LPAm = 37 dB (A)		
		Printing (Quiet Mode)	LPAm = 54 dB (A)		
	Sound Power	Printing	LWad = 6.64 B (A)	LWad = 6.58 B (A)	
		Ready	LWad = 4.62 B (A)	LWad = 4.60 B (A)	
		Printing (Quiet Mode)	LWad = 6.4 B (A)		
Temperature		Operating	50 °F to 90.5 °F (10 to 32.5 °C)		
		Storage	32 °F to 104 °F (0 to 40 °C)		
Humidity		Operating	20 to 80% (without condensation)		
		Storage	10 to 90% (without condensation)		
ADF (automatic document feeder)		Up to 50 pages (DCP-8150DN and DCP-8155DN) Up to 35 pages (DCP-8110DN) For best results we recommend: Temperature: 68 °F to 86 °F (20 °C to 30 °C) Humidity: 50% to 70% Paper: 20 lb (80 g/m ²)			



Document Size

Model		DCP-8110DN	DCP-8150DN	DCP-8155DN
Document Size (Single-sided)	ADF Width	5.8 to 8.5 in. (147.3 to 215.9 mm)		
	ADF Length	5.8 to 14.0 in. (147.3 to 355.6 mm)		
	Scanner Glass Width	Max. 8.5 in. (215.9 mm)		
	Scanner Glass Length	Max. 11.8 in. (300.0 mm)	Max. 14.0 in. (355.6 mm)	
Document Size (2-sided (Duplex))	ADF Width	-		5.8 to 8.5 in. (147.3 to 215.9 mm)
	ADF Length	-		5.8 to 14.0 in. (147.3 to 355.6 mm)

Print media

Model		DCP-8110DN	DCP-8150DN	DCP-8155DN
Paper Input	Paper Tray (Standard)	Paper Type	Plain Paper, Thin Paper, Recycled Paper	
		Paper Size	Letter, A4, B5 (ISO/JIS), A5, A5 (Long Edge), B6 (ISO), A6, Executive, Legal, Folio	
		Paper Weight	16 to 28 lb (60 to 105 g/m ²)	
		Maximum Paper Capacity	Up to 250 sheets of 20 lb (80 g/m ²) Plain paper	
	Multi-purpose tray (MP tray)	Paper Type	Plain Paper, Thin Paper, Thick Paper, Thicker Paper, Recycled Paper, Bond Paper, Label, Envelope, Env.Thin, Env.Thick	
		Paper Size	Width: 3 to 8.5 in (76.2 to 215.9 mm) Length: 5 to 14 in (127.0 to 355.6 mm)	
		Paper Weight	16 to 43 lb (60 to 163 g/m ²)	
		Maximum Paper Capacity	Up to 50 sheets of 20 lb (80 g/m ²) Plain paper	
	Paper Tray 2 (Optional)	Paper Type	-	Plain Paper, Thin Paper, Recycled Paper
		Paper Size	-	Letter, A4, B5 (ISO/JIS), A5, B6 (ISO), Executive, Legal, Folio
		Paper Weight	-	16 to 28 lb (60 to 105 g/m ²)
		Maximum Paper Capacity	-	Up to 500 sheets of 20 lb (80 g/m ²) Plain paper
Paper Output ¹	Face-Down Output Tray		Up to 150 sheets of 20 lb (80 g/m ²) Plain Paper (face-down delivery to the face-down output paper tray)	
	Face-Up Output Tray		One sheet (face-up delivery to the face-up output tray)	
Duplex	Automatic Duplex Printing	Paper Type	Plain Paper, Thin Paper, Recycled Paper	
		Paper Size	Letter, Legal, Folio	
		Paper Weight	16 to 28 lb (60 to 105 g/m ²)	

¹ For labels, we recommend removing printed pages from the output paper tray immediately after they exit the machine to avoid the possibility of smudging.

Copy

Model	DCP-8110DN	DCP-8150DN	DCP-8155DN
Copy Width	Max. 8.27 in. (210 mm)		
Automatic 2-sided (Duplex) Copy	-		Yes (from ADF)
Multiple Copies	Stacks or Sorts up to 99 pages		
Reduce/Enlarge	25% to 400% (in increments of 1%)		
Resolution	Up to 1200 × 600 dpi		
First Copy Out Time ¹	Less than 10.5 seconds at 73.4 °F (23 °C) / 115 V		

¹ From Ready mode and standard tray

Scanner

Model	DCP-8110DN	DCP-8150DN	DCP-8155DN
Color / Mono	Yes / Yes		
TWAIN Compliant	Yes (Windows® XP / Windows Vista® / Windows® 7 / Mac OS X 10.5.8, 10.6.x, 10.7.x ¹)		
WIA Compliant	Yes (Windows® XP / Windows Vista® / Windows® 7)		
ICA Compliant	Yes (Mac OS X 10.6.x, 10.7.x)		
Color Depth	48 bit internal / 24 bit external color		
Resolution	Up to 19200 × 19200 dpi (interpolated) ² Up to 1200 × 1200 dpi (optical) ² (from Scanner Glass) Up to 1200 × 600 dpi (optical) ² (from ADF)		
Scanning Width	Max. 8.27 in. (210 mm)		
Automatic 2-sided (Duplex) Scanning	-		Yes (from ADF)
Gray Scale	256 levels		

¹ For the latest driver updates for the version of Mac OS X you are using, visit us at <http://solutions.brother.com/>.

² Maximum 1200 × 1200 dpi scanning with the WIA driver in Windows® XP, Windows Vista® and Windows® 7 (resolution up to 19200 × 19200 dpi can be selected by using the scanner utility)

Printer

Model	DCP-8110DN	DCP-8150DN	DCP-8155DN
Automatic 2-sided (Duplex) Print	Yes		
Emulations	PCL6, BR-Script3 (PostScript® 3™), IBM Proprinter XL, Epson FX-850		
Resolution	1200 dpi × 1200 dpi, HQ1200 (2400 × 600 dpi) quality, 600 dpi × 600 dpi		
Print Speed (Duplex)	Up to 18 sides/minute (Up to 9 sheets/minute) (Letter size) ¹		
Print Speed	Up to 38 pages/minute (Letter size) ¹	Up to 40 pages/minute (Letter size) ¹	
First Print Time ²	Less than 8.5 seconds at 73.4 °F (23 °C) / 115 V		

¹ The print speed may vary depending on the type of document you print.

² From Ready mode and standard tray

Direct Print feature

Model	DCP-8110DN	DCP-8150DN	DCP-8155DN
Compatibility	PDF version 1.7 ¹ , JPEG, Exif + JPEG, PRN (created by Brother printer driver), TIFF (scanned by all Brother MFC or DCP models), XPS version 1.0		
Interface	USB direct interface		

¹ PDF data including a JBIG2 image file, a JPEG2000 image file or a transparency file is not supported.

Computer requirements

Minimum System Requirements and Supported PC Software Functions								
Computer Platform & Operating System Version		Processor Minimum Speed	Minimum RAM	Recommended RAM	Hard Disk Space to install		Supported PC Software Functions	Supported PC Interface ²
					For Drivers	For Applications		
Windows [®] Operating System	Windows [®] XP Home ^{1 3} Windows [®] XP Professional ^{1 3}	Intel [®] Pentium [®] II or equivalent	128 MB	256 MB	150 MB	500 MB	Printing, Scanning	USB, 10Base-T/100Base-TX (Ethernet)
	Windows [®] XP Professional x64 Edition ^{1 3}	64-bit (Intel [®] 64 or AMD64) supported CPU	256 MB	512 MB				
	Windows Vista [®] ^{1 3}	Intel [®] Pentium [®] 4 or equivalent 64-bit (Intel [®] 64 or AMD64) supported CPU	512 MB	1 GB	500 MB	1.2 GB		
	Windows [®] 7 ^{1 3}	Intel [®] Pentium [®] 4 or equivalent 64-bit (Intel [®] 64 or AMD64) supported CPU	1 GB (32-bit) 2 GB (64-bit)	1 GB (32-bit) 2 GB (64-bit)	650 MB			

Minimum System Requirements and Supported PC Software Functions								
Computer Platform & Operating System Version		Processor Minimum Speed	Minimum RAM	Recommended RAM	Hard Disk Space to install		Supported PC Software Functions	Supported PC Interface ²
					For Drivers	For Applications		
	Windows Server [®] 2003 (print only via network)	Intel [®] Pentium [®] III or equivalent	256 MB	512 MB	50 MB	N/A	Printing	10Base-T/ 100Base-TX (Ethernet)
	Windows Server [®] 2003 x64 Edition (print only via network)	64-bit (Intel [®] 64 or AMD64) supported CPU						
	Windows Server [®] 2008 (print only via network)	Intel [®] Pentium [®] 4 or equivalent 64-bit (Intel [®] 64 or AMD64) supported CPU	512 MB	2 GB				
	Windows Server [®] 2008 R2 (print only via network)	64-bit (Intel [®] 64 or AMD64) supported CPU						
Macintosh Operating System	Mac OS X 10.5.8	PowerPC [®] G4/G5 Intel [®] Processor	512 MB	1 GB	80 MB	400 MB	Printing, Scanning	USB, 10Base-T/ 100Base-TX (Ethernet)
	Mac OS X 10.6.x	Intel [®] Processor	1 GB	2 GB				
	Mac OS X 10.7.x	Intel [®] Processor	2 GB	2 GB				

¹ For WIA, 1200 x 1200 resolution. Brother Scanner Utility enables to enhance up to 19200 x 19200 dpi.

² Third-party USB ports are not supported.

³ Nuance[™] PaperPort[™] 12SE supports Microsoft[®] SP3 or higher for Windows[®] XP and SP2 or higher for Windows Vista[®] and Windows[®] 7.

For the latest driver updates, visit <http://solutions.brother.com/>.

All trademarks, brand and product names are property of their respective companies.

Consumable items

Model		DCP-8110DN	DCP-8150DN	DCP-8155DN	Order No.
Toner Cartridge	Inbox	Approx. 2,000 pages Letter or A4 page ¹	Approx. 3,000 pages Letter or A4 page ¹		-
	Standard	Approx. 3,000 pages Letter or A4 page ¹			TN-720
	High Yield	Approx. 8,000 pages Letter or A4 page ¹			TN-750
Drum Unit		Approx. 30,000 pages Letter or A4 pages (1 page / job) ²			DR-720

¹ Approx. cartridge yield is declared in accordance with ISO/IEC 19752.

² Drum life is approximate and may vary by type of use.

Interfaces

Model	DCP-8110DN	DCP-8150DN	DCP-8155DN
USB	Hi-Speed USB 2.0 ^{1 2} It is recommended you use a USB 2.0 cable (Type A/B) that is no more than 6 feet (2 meters) long.		
Ethernet ³	10BASE-T / 100BASE-TX Use an Ethernet U/UTP cable category 5 or greater.		

¹ Your machine has a Hi-Speed USB 2.0 interface. The machine can also be connected to a computer that has a USB 1.1 interface.

² Third-party USB ports are not supported.

³ For detailed network specifications, see *Network (LAN)* >> page 114 and >>> Network User's Guide.

Network (LAN)

Note

For more information about the Network specifications, see the Network User's Guide.

Model		DCP-8110DN	DCP-8150DN	DCP-8155DN
LAN		You can connect your machine to a network for Network Printing and Network Scanning. Also included is Brother BRAdmin Light ¹ ² Network Management software.		
Protocols	IPv4	ARP, RARP, BOOTP, DHCP, APIPA (Auto IP), WINS/NetBIOS name resolution, DNS Resolver, mDNS, LLMNR responder, LPR/LPD, Custom Raw Port/Port9100, SMTP Client, IPP/IPPS, FTP Client and Server, CIFS Client, TELNET Server, SNMPv1/v2c/v3, HTTP/HTTPS server, TFTP client and server, ICMP, Web Services (Print/Scan), SNTN Client		
	IPv6	NDP, RA, DNS resolver, mDNS, LLMNR responder, LPR/LPD, Custom Raw Port/Port9100, IPP/IPPS, FTP Client and Server, CIFS Client, TELNET Server, SNMPv1/v2c/v3, HTTP/HTTPS server, TFTP client and server, SMTP Client, ICMPv6, SNTN Client, Web Services (Print/Scan)		
Security Protocols	Wired	APOP, POP before SMTP, SMTP-AUTH, SSL/TLS (IPPS, HTTPS, SMTP, POP), SNMP v3, 802.1x (EAP-MD5, EAP-FAST, PEAP, EAP-TLS, EAP-TTLS), Kerberos		

¹ (For Windows® users) Brother BRAdmin Light is available on the CD-ROM provided with the machine.

(For Macintosh users) Brother BRAdmin Light is available as a download from <http://solutions.brother.com/>.

² (For Windows® users) If you require more advanced machine management, use the latest Brother BRAdmin Professional utility version that is available as a download from <http://solutions.brother.com/>.

A

- Accessories and supplies ii
- ADF (automatic document feeder)
 - using23
- Apple Macintosh
 - See Software User's Guide.

B

- Brother
 - accessories and supplies ii
 - Brother numbers i
 - Customer Service i
 - FAQs (frequently asked questions) i
 - product support i
 - service centers i
 - warranties iii

C

- Cleaning
 - corona wire45
- Consumable items 37, 38
- Control panel overview6
- ControlCenter2 (for Macintosh)
 - See Software User's Guide.
- ControlCenter4 (for Windows®)
 - See Software User's Guide.
- Copy
 - keys6

D

- Dimensions102
- Direct print26
 - Direct key27
 - specification109
- Document
 - how to load 23, 24
- Drum unit
 - cleaning45
 - replacing47

E

- Envelopes 13, 18, 19, 21
- Error messages on LCD 53
 - No Paper55
 - Out of Memory56
 - Print Unable XX56
 - Scan Unable XX57

F

- Folio 16, 19

G

- Gray scale 107

H

- HELP
 - LCD messages 87
 - Menu Table 88

L

- Labels 11, 18, 19, 22
- LCD (liquid crystal display) 6, 87

M

- Machine information
 - how to reset the machine 86
 - reset functions 86
 - serial number 86
 - status LED 8
- Macintosh
 - See Software User's Guide.
- Maintenance, routine
 - replacing
 - drum unit47
 - toner cartridge39
- Memory102
- Menu Table 88
- Mode, entering
 - copy25
 - scan7

N

- Network
 - printing
 - See Network User's Guide.
 - scanning
 - See Software User's Guide.
- Network connectivity 113
- Nuance™ PaperPort™ 12SE
 - See Software User's Guide. See also Help in the Nuance™ PaperPort™ 12SE application to access How-to-Guides.

O

- Out of Memory message 56

P

- Paper 18
 - how to load 9
 - in multi-purpose tray 11
 - in paper tray 9
 - recommended 18, 19
 - size 16, 18
 - tray capacity 19
 - type 16, 18
- Presto! PageManager
 - See Software User's Guide. See also Help in the Presto! PageManager application.
- Print
 - difficulties 72
 - document from your computer 30
 - drivers 108
 - quality 78
 - resolution 108
 - specifications 108
- Printing
 - See Software User's Guide.
- Programming your machine 87

Q

- Quality
 - printing 78

R

- Replacing
 - drum unit 47
 - toner cartridge 39
- Resolution
 - copy 106
 - print 108
 - scan 107

S

- Scan a document to a computer 31
- Scanner glass
 - using 24
- Scanning
 - See Software User's Guide.
- Secure Print key 7
- Serial number
 - how to find See inside front cover
- Service centers i
- Status LED 8

T

- Text, entering 100
- Toner cartridge
 - replacing 39
- Troubleshooting 72
 - document jam 59, 60
 - error messages on LCD 53
 - if you are having difficulty
 - copy quality 75
 - network 76
 - paper handling 74
 - print quality 78
 - printing 72
 - scanning 75
 - software 75
 - maintenance messages on LCD 53
 - paper jam 61, 62, 63, 66, 70

W

- Warranties
 - Notice-Disclaimer iii
- Weights 103
- Windows®
 - See Software User's Guide.
- World Wide Web i

Brother International Corporation
100 Somerset Corporate Boulevard
P.O. Box 6911
Bridgewater, NJ 08807-0911 USA

Brother International Corporation (Canada) Ltd.
1 rue Hôtel de Ville,
Dollard-des-Ormeaux, QC, Canada H9B 3H6

brother®

Visit us on the World Wide Web
<http://www.brother.com/>

These machines are approved for use in the country of purchase only. Local Brother companies or their dealers will only support machines purchased in their own countries.