

brother[®]

Brother Laser Printer

HL-1800 series

USER'S GUIDE

Please read this guide thoroughly before you use the printer. You can print or view this guide from the CD-ROM at any time. Please keep the CD-ROM in a convenient place for quick and easy reference at all times.

Version 2



Laser Printer

HL-1800 series

USER'S GUIDE

(For USA & Canada only)

IMPORTANT NOTE: If you have any questions about using your printer, you must call while you are in the country where you purchased the machine.

In USA 1-800-276-7746

In Canada 1-800-853-6660
1-514-685-6464 **In Montreal**

If you have any comments or suggestions, please write us at:

In USA Printer Customer Support
Brother International Corporation
15 Musick
Irvine, CA 92618

In Canada Brother International Corporation (Canada), Ltd.
- Marketing Dept.
1, rue Hôtel de Ville
Dollard-des-Ormeaux, PQ, Canada H9B 3H6

BROTHER FAX-BACK SYSTEM

Brother Customer Service has set up an easy-to-use fax-back system so you can get instant answers to common technical questions and information about our products. This is available 24 hours a day, 7 days a week. We can send the information to any fax machine, not just the one from which you are calling.

Call and follow the voice prompts to receive faxed instructions on how to use the system and your index of fax-back subjects.

In USA 1-800-521-2846

In Canada 1-800-685-5381
1-514-685-5381 **In Montreal**

DEALERS/SERVICE CENTERS (USA only)

For the name of a Brother authorized dealer or service center, call 1-800-284-4357.

SERVICE CENTERS (Canada only)

For service center addresses in Canada, call 1-800-853-6660.

INTERNET ADDRESS

Brother Global Web Site: <http://www.brother.com>

For Frequently Asked Questions (FAQs), Product Support, Technical Questions and Driver Updates:

<http://solutions.brother.com>

(USA only) For Brother Accessories and Supplies: <http://www.brothermall.com>

Definitions of Warnings, Cautions and Notes

The following conventions are used in this User's Guide:



Warning

Indicates warnings that must be observed to prevent possible personal injury.



Caution

Indicates cautions that must be observed to use the printer properly or prevent damage to the printer.

Note

Indicates notes and useful tips to remember when using the printer.

To Use the Printer Safely



Warning

After you have just used the printer, some internal parts of the printer are extremely **HOT!** When you open the covers of the printer, never touch the shaded parts shown in the following illustrations.

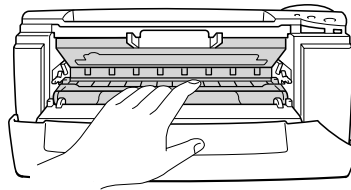

Caution

After you have just used the printer, some internal parts of the printer are extremely **HOT!** Wait for the printer to cool down before you touch the internal parts of the printer.

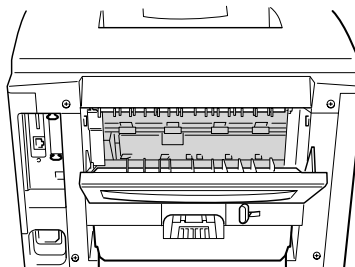

TABLE OF CONTENTS

| | |
|---|-----|
| Definitions of Warnings, Cautions and Notes | ii |
| To Use the Printer Safely | iii |
| TABLE OF CONTENTS | iv |

CHAPTER 1 ABOUT THIS PRINTER

| | |
|---|------|
| What Is in the Carton..... | 1-1 |
| Components..... | 1-1 |
| General View..... | 1-3 |
| Positioning the Printer | 1-5 |
| Power supply..... | 1-5 |
| Environment | 1-6 |
| What Kind of Paper Can I Use? | 1-7 |
| Type and Size of Paper..... | 1-7 |
| Choose the Paper Size, Media Type and so on in the Printer Driver Settings | 1-9 |
| PCL Driver..... | 1-9 |
| PS Driver..... | 1-10 |
| Macintosh Driver..... | 1-11 |
| Printable Area..... | 1-13 |
| Printing from the Paper Cassette | 1-14 |
| Printing from the Multi-purpose Tray | 1-17 |
| Printing to the Face Up Output Tray (Face up printing) | 1-20 |
| Printing Envelopes | 1-22 |
| Printing on Labels and Transparencies | 1-27 |
| Printing on Both Sides of the Paper (Duplex printing) | 1-30 |
| Booklet Printing (For PCL Driver Only) | 1-34 |
| Manual Feed | 1-36 |

CHAPTER 2 DRIVER AND SOFTWARE

| | |
|---|-------------|
| Printer Driver | 2-1 |
| Features in the PCL Printer Driver (Windows® Users Only) | 2-2 |
| Basic Tab | 2-2 |
| Advanced Tab | 2-3 |
| Accessories | 2-8 |
| Support Tab | 2-9 |
| Features in the PS Printer Driver (Windows® Users Only) | 2-10 |
| Details Tab | 2-10 |
| Paper Tab | 2-11 |
| Graphics | 2-12 |
| Device Options | 2-13 |
| Features in the PS Printer Driver (Mac OS® 8.6 to 9.2/Mac OS® X 10.1 only) | 2-14 |
| Page Setup | 2-14 |
| Layout | 2-15 |
| Specific Options | 2-16 |
| Software for Networks | 2-17 |
| Software installation for Windows Computers | 2-18 |
| Software Installation for Macintosh Computers | 2-19 |
| Apple LaserWriter 8 Driver | 2-19 |
| PostScript Printer Description Files (PPDs) | 2-19 |
| Automatic Emulation Selection | 2-20 |
| Automatic Interface Selection | 2-21 |
| Printer Settings | 2-22 |
| Factory Settings | 2-22 |

CHAPTER 3 CONTROL PANEL

| | |
|--|------|
| Control Panel..... | 3-1 |
| Buttons | 3-2 |
| Go Button..... | 3-3 |
| Job Cancel Button | 3-4 |
| Reprint Button | 3-5 |
| Reprinting the Last JOB | 3-6 |
| Printing SECURE Data..... | 3-8 |
| Menu (+ / - / Set / Back) Button | 3-11 |
| + / - Button | 3-11 |
| Set Button..... | 3-12 |
| Back Button | 3-12 |
| LED | 3-13 |
| DATA - Orange LED..... | 3-13 |
| LCD Display | 3-14 |
| BACK LIGHTS | 3-14 |
| Printer Status Messages | 3-15 |
| How to Use the Control Panel | 3-16 |
| Control Panel Menus..... | 3-18 |
| INFORMATION..... | 3-19 |
| PAPER..... | 3-20 |
| QUALITY | 3-20 |
| SETUP..... | 3-21 |
| PRINT MENU | 3-22 |
| NETWORK | 3-26 |
| INTERFACE..... | 3-27 |
| RESET MENU | 3-28 |
| Set IP Address..... | 3-29 |
| About Emulation Modes | 3-30 |
| List of Factory Settings | 3-31 |

CHAPTER 4 OPTIONS

| | |
|--|------|
| Optional Accessories..... | 4-1 |
| Lower Tray Unit (LT-500) | 4-2 |
| Installing the Lower Tray Unit..... | 4-3 |
| Network Option NC-4100h (For HL-1850 User Only)..... | 4-5 |
| Installing the Network Board..... | 4-5 |
| RAM Expansion..... | 4-9 |
| Installing Additional Memory..... | 4-13 |
| IrDA Interface (IR-1000) | 4-16 |
| Optional Font Package (BS-3000)..... | 4-17 |

CHAPTER 5 ROUTINE MAINTENANCE

| | |
|-------------------------------------|------|
| Replacing the Consumables..... | 5-1 |
| Replacing Maintenance Parts..... | 5-2 |
| Toner Cartridge..... | 5-3 |
| TONER LOW Message..... | 5-4 |
| TONER EMPTY Message | 5-5 |
| Replacing the Toner Cartridge | 5-5 |
| CHANGE DRUM SOON Message..... | 5-11 |
| Replacing the Drum Unit | 5-11 |
| Cleaning | 5-14 |
| Cleaning the Printer Exterior | 5-14 |
| Cleaning the Printer Interior | 5-15 |
| Cleaning the Corona Wire | 5-17 |
| Maintenance Messages..... | 5-19 |

CHAPTER 6 TROUBLESHOOTING

| | |
|---------------------------------------|------|
| LCD Messages..... | 6-1 |
| Error Messages..... | 6-1 |
| Maintenance Messages..... | 6-3 |
| Service Call Messages..... | 6-4 |
| Troubleshooting Paper Handling..... | 6-5 |
| Paper Jams and How to Clear Them..... | 6-6 |
| JAM TRAY1..... | 6-7 |
| JAM TRAY2..... | 6-9 |
| JAM MP TRAY..... | 6-10 |
| JAM INSIDE..... | 6-11 |
| JAM REAR..... | 6-13 |
| JAM DUPLEX..... | 6-17 |
| PAPER JAM..... | 6-20 |
| Improving the Print Quality..... | 6-23 |
| How to Print Correctly..... | 6-29 |
| Other Problems..... | 6-30 |
| For DOS Users..... | 6-30 |
| BR-Script 3 Language..... | 6-31 |

APPENDIX

| | |
|--|-------------|
| Printer Specifications | A-1 |
| Print Media and Size | A-5 |
| What Is Important When You Choose Paper to Use with This Printer..... | A-8 |
| Emulation Modes | A-11 |
| HP LaserJet Mode..... | A-11 |
| BR-Script 3 Mode | A-11 |
| EPSON FX-850 and IBM Proprinter XL Modes | A-12 |
| Resident Fonts | A-13 |
| 66 Scalable and 12 Bitmapped Fonts..... | A-13 |
| HP LaserJet, EPSON FX-850 and IBM Proprinter XL Modes | A-13 |
| BR-Script 3 Mode | A-15 |
| Symbol Sets / Character Sets | A-16 |
| OCR Symbol Sets | A-16 |
| HP LaserJet Mode..... | A-17 |
| EPSON Mode..... | A-18 |
| IBM Mode..... | A-18 |
| Trademarks | A-23 |
| Regulations | A-24 |

| | |
|---------------------------|-------------------|
| <i>INDEX</i> | <i>I-1</i> |
|---------------------------|-------------------|

CHAPTER 1

ABOUT THIS PRINTER

What Is in the Carton

Components

When you unpack the printer, check to see that you have all of the following parts.

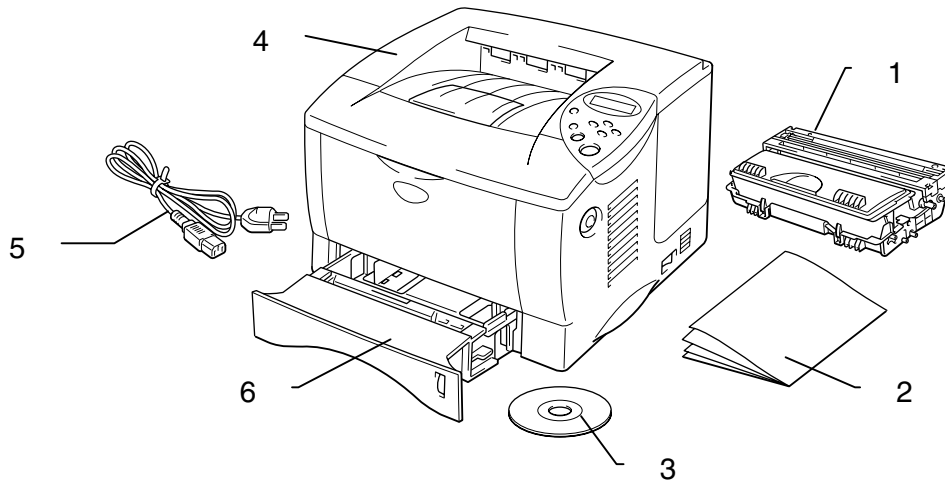

Fig. 1-1

1. Drum Unit Assembly (with Toner Cartridge)
2. Documentation
3. CD-ROM
4. Printer
5. AC Power Cord
6. Paper Cassette

•• **Note**

- An interface cable is not a standard accessory. Some computers have both a USB and a parallel port. Please purchase the appropriate cable for the interface you intend to use. Most parallel cables support bi-directional communication, but some might have an incompatible pin assignment or may not be IEEE 1284-compliant.
 - Do not use a parallel cable that is longer than 3 metres (10 feet).
 - The power cord may differ slightly from this figure depending on the country where you purchased the printer.
 - When you use a USB cable, make sure to use a high-speed twisted cable (12Mbps), and connect it to the USB connector of your PC. Do not use the USB connector on the front of your PC or on the iMac's keyboard.
-

General View

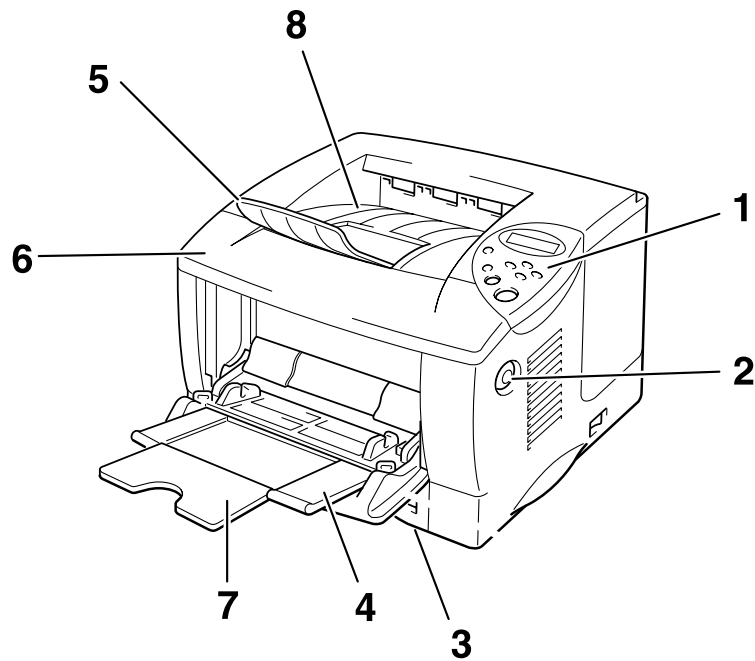

Fig. 1-2

- 1 Control Panel
- 2 Cover Release Button
- 3 Paper Cassette
- 4 Multi-purpose Tray
- 5 Extension Flap
- 6 Front cover
- 7 Multi-purpose Tray Extension
- 8 Face Down Output Tray

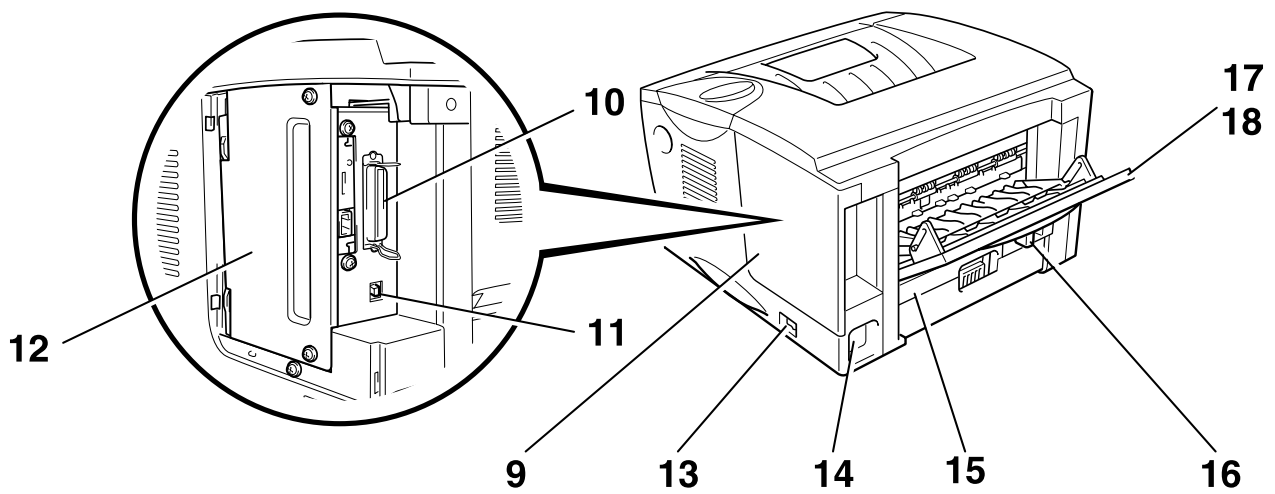

Fig. 1-3

- 9 Interface Cover
- 10 Parallel Interface Connector
- 11 USB Connector
- 12 PCB Access Plate
- 13 Power Switch
- 14 AC Power Inlet
- 15 Duplex Tray
- 16 Paper Adjustment Lever for Duplex Printing
- 17 Face Up Output Tray
- 18 Face Up Tray Extension

Positioning the Printer

Please note the following before using the printer.

Power supply

Use the printer within the specified power range:

AC power:

- AC 220-240 V 50/60 Hz or
- AC 100-120 V 50/60 Hz

The power cord, including extensions, should not exceed 5 metres (16 ½ feet).

Do not share the same power circuit with other high-power appliances such as an air conditioner, copier, shredder and so on. If you cannot avoid using the printer with these appliances, we recommend that you use an isolation transformer or a high-frequency noise filter.

Use a voltage regulator if the power source is not stable.

Environment

Use the printer only within the following ranges of temperature and humidity:

Ambient temperature: 10°C to 32.5°C (50°F to 90.5°F)

Ambient humidity: 20% to 80% (without condensation)

Do not block the air exit on top of the printer. Do not place objects on top of the printer, especially on the air vent.

Ventilate the room in which you use the printer.

Do not put the printer in direct sunlight. Use a blind or a heavy curtain to protect the printer from direct sunlight if you have to put the printer near a window.

Do not install the printer near devices that contain magnets or generate magnetic fields.

Do not drop, bang or shake the printer. Do not expose the printer to open flames or salty or corrosive gases.

Put the printer on a flat, horizontal surface.

Keep the printer clean. Do not install the printer in a dusty place.

Do not install the printer near an air conditioner.

Do not put the printer where the air vent of the printer can be blocked. Keep a gap of approximately 100 mm (4 inches) between the air vent and the wall.

What Kind of Paper Can I Use?

Type and Size of Paper

The names we used for the paper trays and their LCD panel descriptions are shown below:

| | |
|---------------------|---------|
| Upper Paper Tray | Tray 1 |
| Multi-purpose Tray | MP tray |
| Optional Lower Tray | Tray 2 |

The printer usually loads paper from the installed Multi-purpose Tray, Upper Paper Tray or Optional Lower Paper Tray.

❖ Note

Use your computer to view each selection in the following table

Click on the ticks in the following table when you want to see detailed information about each selection.

| Media Type | Tray 1 | MP tray | Tray 2 | Duplex Printing | Select the Media Type from the printer driver |
|-----------------------|---------------|----------------|---------------|------------------------|--|
| Plain Paper | ✓ | ✓ | ✓ | ✓ | Plain paper |
| Recycled Paper | ✓ | ✓ | ✓ | ✓ | Plain paper |
| Bond Paper | ✓ | ✓ | ✓ | | Bond paper |
| Thick Paper | | ✓ | | | Thick paper or Thicker paper |
| Transparencies | | ✓ | | | Transparencies |
| Label | | ✓ | | | Plain paper |
| Envelopes | | ✓ | | | Envelopes Envelopes – Thin Envelopes - Thick |
| Card Stock | ✓ | ✓ | | | Thick paper or Thicker paper |

| | Upper Paper Tray (Tray 1) | Multi-purpose Tray (MP Tray) | Optional Lower Tray Unit (Tray 2) | Duplex Printing |
|-------------------|--|---|--|------------------------|
| Paper Size | A4, Letter, Legal, 8.5 x 13 in., B5 (JIS), B5 (ISO), Executive, A5, A6, B6 | Width: 70 to 216 mm (2.75 to 8.5 in.) Length: 116 to 356 mm (4.57 to 14.0 in.) | A4, Letter, Legal, B5 (JIS), B5 (ISO), Executive, A5 | A4, Letter, Legal |
| Capacity | 250 sheets (80 g/m ² or 21 lbs.) | 100 sheets (80 g/m ² or 21 lbs.) Legal : 30 8.5 x 13 in. : 30 labels : 10 | 250 sheets (80 g/m ² or 21 lbs.) | |

We recommend the following print methods (output tray) for each paper media type:

| Media Type | Paper Output | | Notes |
|-----------------------|---------------------|----------------|--|
| | Face Down | Face up | |
| Plain Paper | ✓ | ✓ | 60 g/m ² to 105 g/m ² (16 to 28 lbs.) |
| Thick Paper | | ✓ | 105 g/m ² to 161 g/m ² (28 to 43 lbs.) |
| Recycled Paper | ✓ | ✓ | |
| Transparencies | ✓ | | OHP films |
| Label | | ✓ | |
| Envelopes | | ✓ | |
| Card Stock | | ✓ | |

•• **Note**

-
- When you print on a double-flap envelope, place it side ways in the Multi-purpose Tray.
 - You can set the priority of the paper sources in Paper Mode from the Control Panel. For more information about the paper settings, see [Chapter 3](#).
-

Choose the Paper Size, Media Type and so on in the Printer Driver Settings

Before printing, choose the Paper size, Media type, Paper Source in the Printer Driver.

❖ PCL Driver

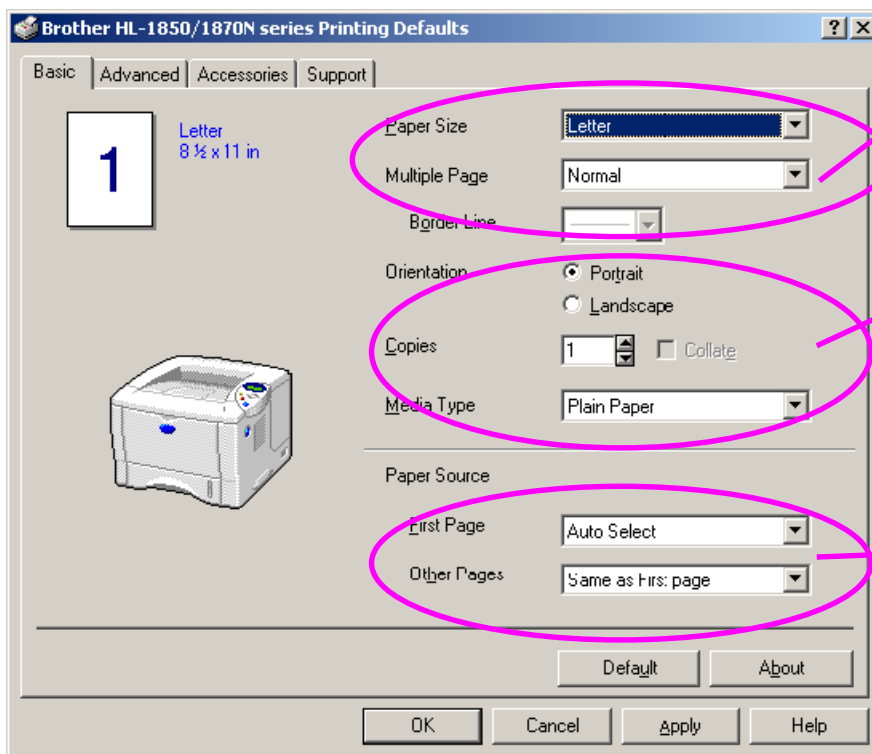

Select the Paper Size and Layout (Multiple Page).

Select the Orientation, number of Copies and Media Type.

Select the Paper Source.

❖ **PS Driver**

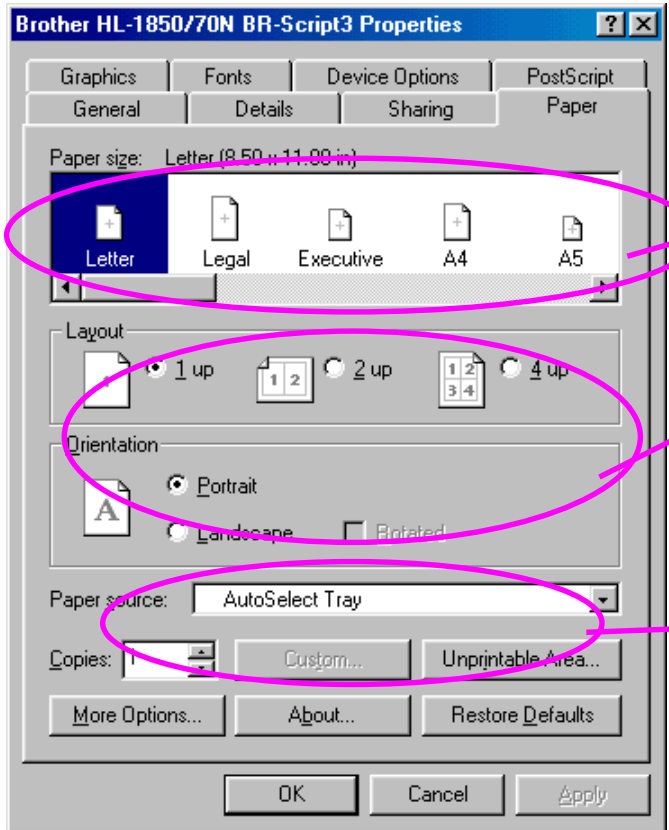

Select the Paper size.

Select the Layout and Orientation.

Select the Paper source and number of Copies.

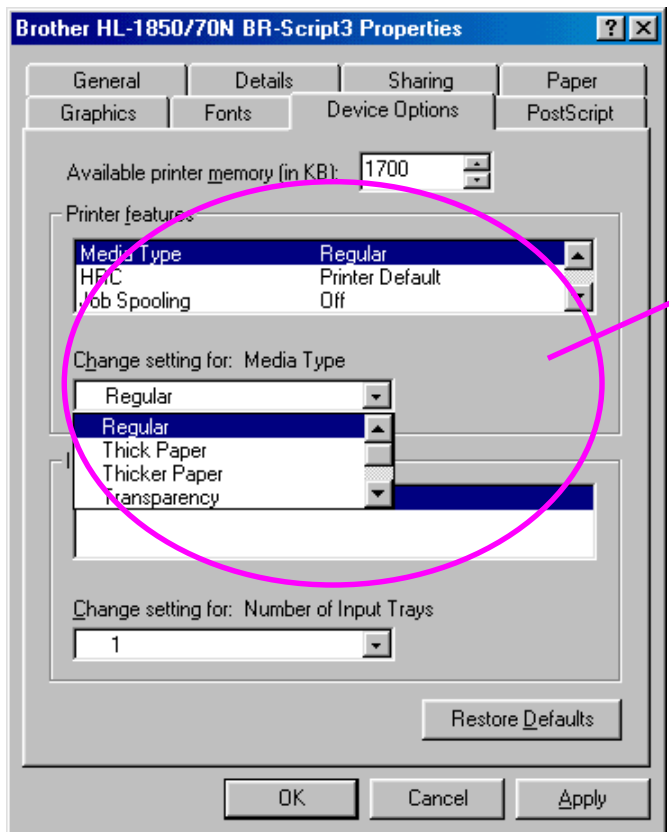

Select the Printer features, and then select the Media Type.

❖ Macintosh Driver

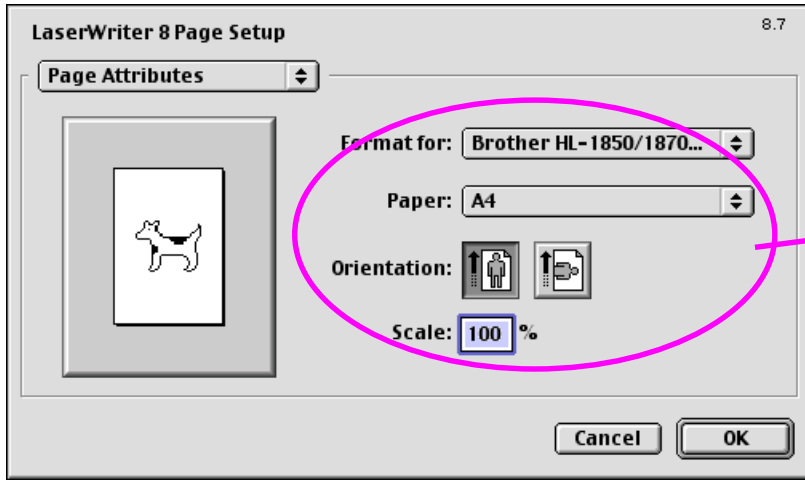

In Page Attributes, select the Paper size, Orientation and Scaling.

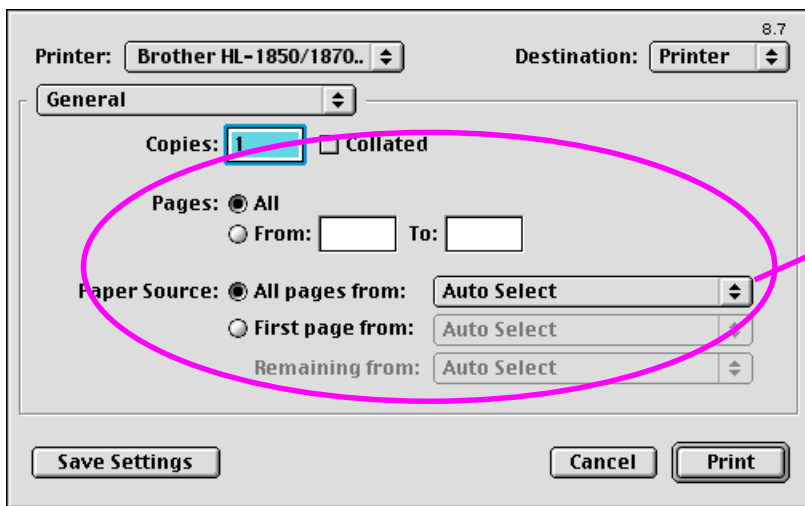

In General, select the number of Copies and Paper Source.

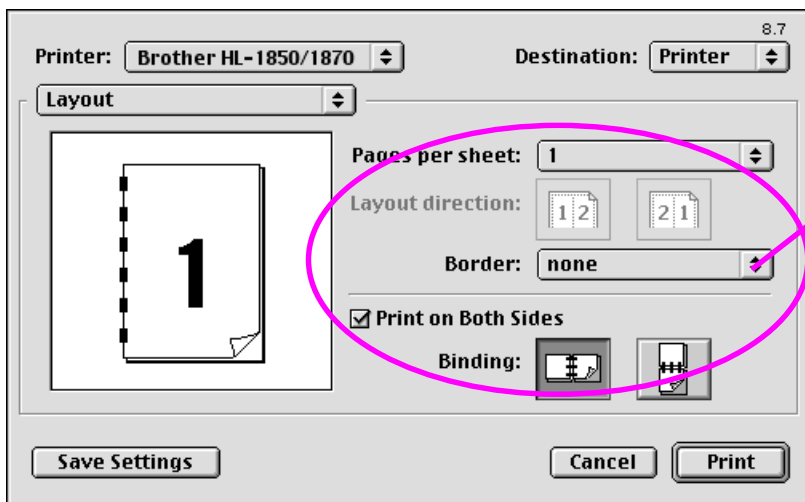

In Layout, select the Pages per sheet, Layout direction and Border. Select Print on Both Sides if you want this to be a two-sided document.

Recommended paper

| | Europe | USA |
|----------------|--|--|
| Plain Paper | Xerox Premier 80 g/m ² Xerox Business 80 g/m ² IGEPA X-Press 80 g/m ² | Xerox 4200DP 20 lb Champion Paper One 20 lb Hammermill Laser Paper 24 lb |
| Recycled Paper | Steinbis Recycling Copy 80 g/m ² | |
| Transparency | 3M CG3300 | 3M CG 3300 |
| Label | Avery laser label L7163 | Avery laser label #5160 |

- ◆ *Before buying a lot of paper, please test some paper to make sure that it is suitable.*
- ◆ *Use paper that is designed for plain paper copying*
- ◆ *Use paper that is 75 to 90 g/m²*
- ◆ *Use neutral paper. Do not use acidic or alkaline paper.*
- ◆ *Use Long grain paper*
- ◆ *Use paper with a moisture content of about 5%*
- ◆ *This printer can use recycled paper that meets the DIN 19309 specification.*

Recommended paper should have the following technical specifications:

- ◆ *Basis Weight 75 – 90 (g/m²)*
- ◆ *Thickness 80-110 (micrometer)*
- ◆ *Roughness Higher than 20 (seconds)*
- ◆ *Stiffness 90-150 (cm³/100)*
- ◆ *Grain Direction Long Grain*
- ◆ *Volume Resistivity 10e9-10e11 (ohm)*
- ◆ *Surface Resistivity 10e10 – 10e12 (ohm-cm)*
- ◆ *Filler CaCO₃ (Neutral)*
- ◆ *Ash Content below 23 (wt%)*
- ◆ *Brightness higher than 80 (%)*
- ◆ *Opacity higher than 85 (%)*

❖ **Printable Area**

The figure below shows the part of the paper that will be printed on.

Portrait

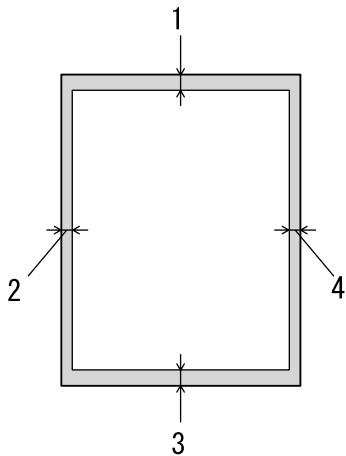

Fig. 1-4

| | Letter | A4 |
|----------|---------------------|-----------|
| 1 | 0.17 inch (4.2 mm) | 4.2 mm |
| 2 | 0.25 inch (6.35 mm) | 6.01 mm |
| 3 | 0.17 inch (4.2 mm) | 4.2 mm |
| 4 | 0.25 inch (6.35 mm) | 6.01 mm |

Landscape

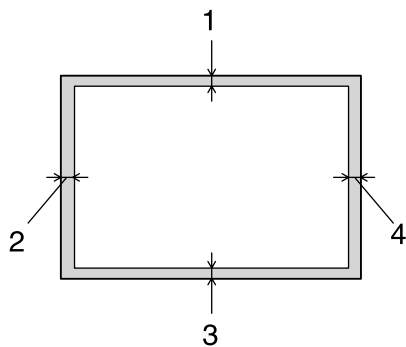

Fig. 1-5

| | Letter | A4 |
|----------|--------------------|-----------|
| 1 | 0.17 inch (4.2 mm) | 4.2 mm |
| 2 | 0.2 inch (5.08 mm) | 5.0 mm |
| 3 | 0.17 inch (4.2 mm) | 4.2 mm |
| 4 | 0.2 inch (5.08 mm) | 5.0 mm |

Printing from the Paper Cassette

1. Pull the paper cassette completely out of the printer.

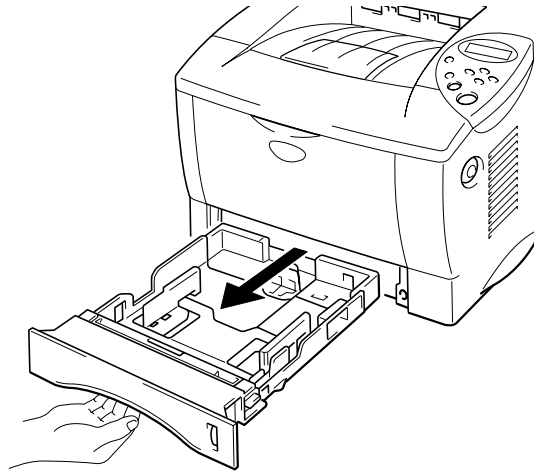

Fig. 1-6

2. Adjust the paper guides at the right-hand side and back of the paper cassette to match the paper size you want to load. Make sure that the tips of the paper guides fit into the slots correctly.

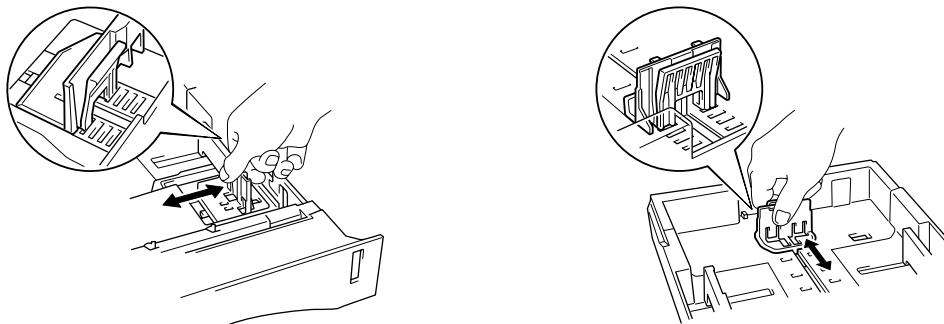

Fig. 1-7

For Legal or 8.5 x 13 in. paper

While pressing the Universal Guide Release Lever, extend the back of the Paper cassette.

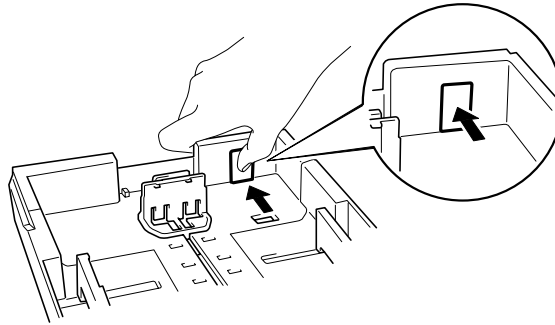

Fig. 1-8

3. Put paper into the paper cassette. Make sure that the paper is flat in the cassette at all four corners and below the limit mark.

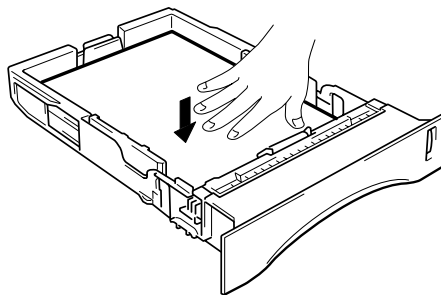
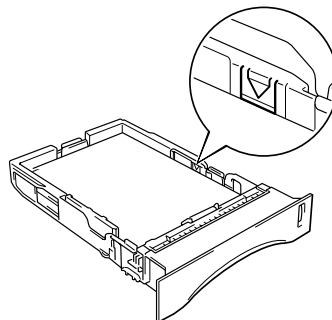

Fig. 1-9

Note

Do not put more than 250 sheets of paper (80 g/m² or 21 lb.) in the cassette or the paper may jam. You can load paper up to the lines on the sliding guide.



4. Put the paper cassette back into the printer. Make sure it is completely in the printer.

Note

-
- Extend the Extension Flap to prevent the paper from sliding off the Face Down Output Tray.
 - If you choose not to extend the Extension Flap, we recommend that you remove paper as soon as it comes out of the printer.
-

When you print on transparencies, use the Face Down Output Tray.

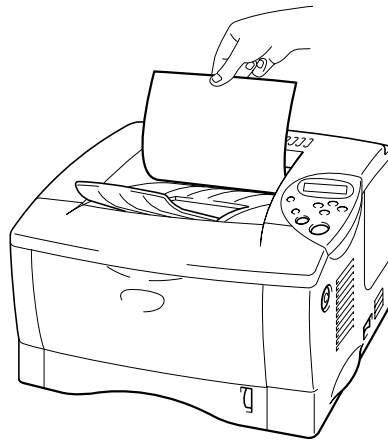

Fig. 1-10

5. Choose the Paper Size, Media Type, Paper Source and so on from the Printer Driver.

Printing from the Multi-purpose Tray

•• Note

- For correct printing, you must select the *same* paper size from within your software application as the paper in the tray.
- If your application software does not support paper size selection in its Print menu, you can change the paper size by using the paper menu on the printer control panel. [For more information, see Chapter 3.](#)

- ☛ 1. Open the Multi-purpose Tray.

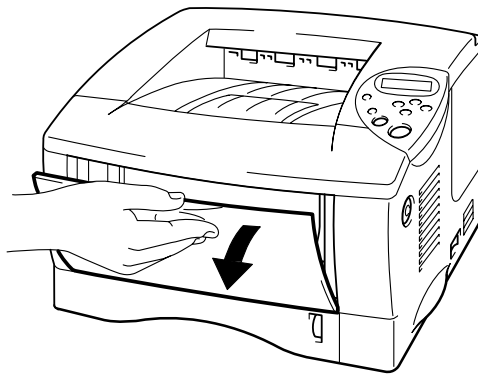

Fig. 1-11

- ☛ 2. Unfold the Multi-purpose Tray Extension.



Fig. 1-12

- ☛ 3. Place paper in the Multi-purpose Tray so it touches the back of the tray and remains below the limit mark.

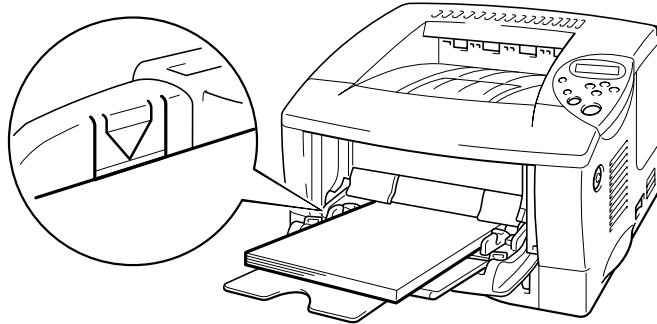

Fig. 1-13

↔ **Note**

When you place paper on the Multi-purpose Tray, note the following:

- If you will be printing on paper that weighs more than 135 g/m² (36 lbs), use the Face Up Output Tray.
 - Insert the leading edge of the paper first and push it gently into the tray.
 - If you use pre-printed paper in the Multi-purpose Tray, the paper should be inserted top edge first with the printed side face up.
-

- ☛ 4. Press and slide the Paper Width Adjuster on the right-hand side to fit the paper.

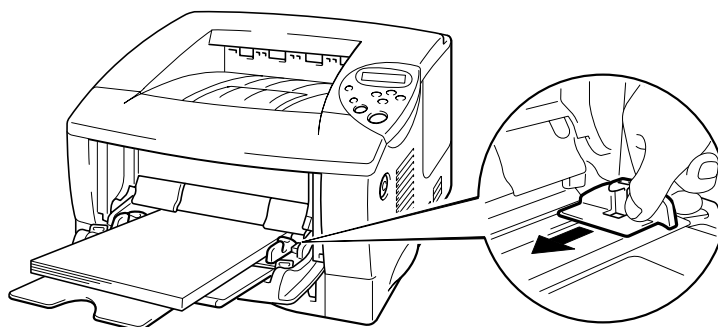
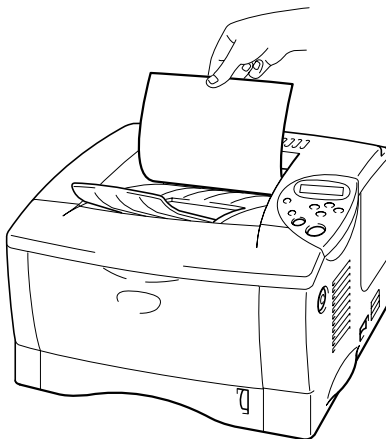

Fig. 1-14

Note

-
- Make sure that the paper is neatly stacked and is correctly seated in the Multi-purpose Tray; otherwise, paper may not be fed correctly, resulting in skewed printouts or paper jams.
 - During printing, the inside of the Multi-purpose tray automatically rises to feed paper into the printer.
 - When you print on transparencies, use the Face Down Output Tray.

**5.**

Select the MP Tray from paper source.
Paper source is in the Basic tab of the printer driver.

Printing to the Face Up Output Tray (Face up printing)

When the Face Up Output Tray is open, the printer has a straight paper path from the Paper Cassette or Multi-purpose Tray to the rear of the printer. Use this output method when you want to print on special media that is thick or should not be bent, such as labels, card stock or envelopes.

When you use Transparencies, print to the Face Down Output Tray.

1. Open the Face Up Output Tray.

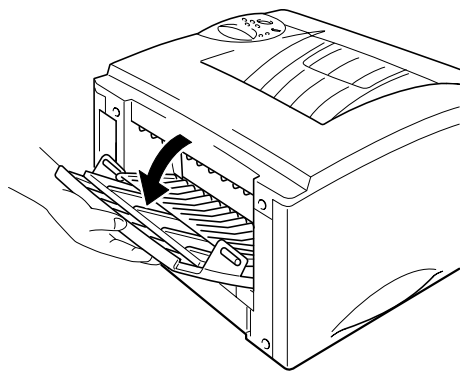

Fig. 1-15

2. Unfold the Face Up Output Tray Extension.

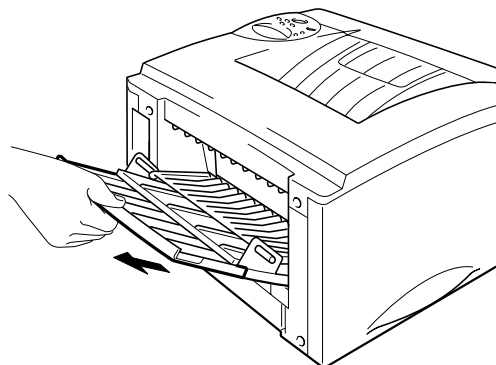

Fig. 1-16

- **3.** Place the paper into the Paper Cassette or Multi-purpose Tray.

- **4.** After the printer ejects all the printed pages, remove them and close the Face Up Output Tray.

Printing Envelopes

Types of envelope to avoid

Do not use envelopes:

- that are damaged, curled, wrinkled, or irregularly shaped;
- that are extremely shiny or highly textured;
- with clasps, snaps or tie strings;
- with self-adhesive closures;
- that are of baggy construction;
- that are not sharply creased;
- that are embossed (that have raised writing on them);
- that were previously printed by a laser printer;
- that are pre-printed on the inside;
- that cannot be arranged uniformly when put in a pile;
- that are made of paper that weighs more than the paper-weight specifications for the printer;
- that have been badly made, with edges that are not straight or consistently square; or
- with transparent windows, holes, cutouts or perforations.

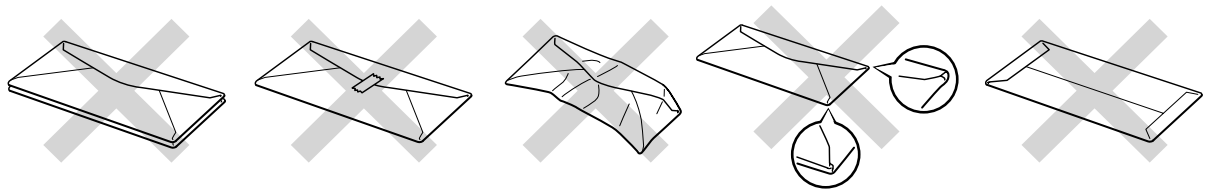
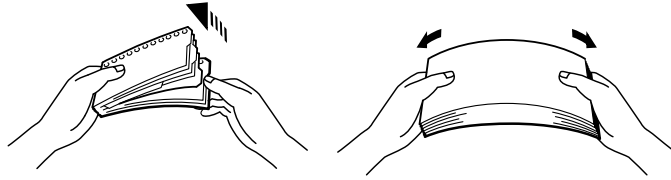

Fig. 1-17

If you use any of the types of envelope listed above, they may damage your printer. This damage is not covered under any warranty or service agreement.

Note

- Before you print envelopes, you must ‘fan’ the stack of envelopes well to avoid paper jams and misfeeds.



- When you print on double-flap envelopes, place them sideways in the Multi-purpose Tray.
- Do not load different types of paper at the same time in the Multi-purpose Tray because paper jams and misfeeds may occur.
- Do not print on envelopes using Duplex Printing.
- For correct printing, you must choose the *same* paper size from within your software application as the paper in the tray.
- If your application software does not support paper size selection in its print menu, you can change the paper size by using the paper menu on the printer control panel. [For more information, see Chapter 3.](#)

1. Open the Multi-purpose Tray.

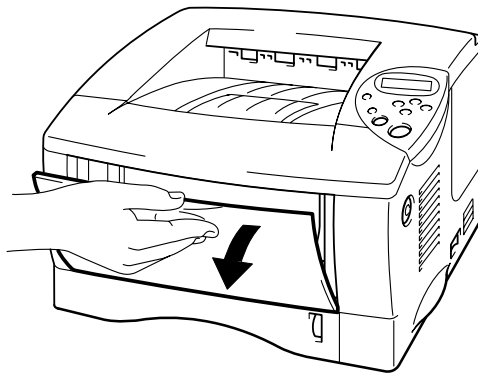

Fig. 1-18

2. Unfold the Multi-purpose Tray Extension.



Fig. 1-19

3. Open the Face Up Output Tray and pull out the extension flap.

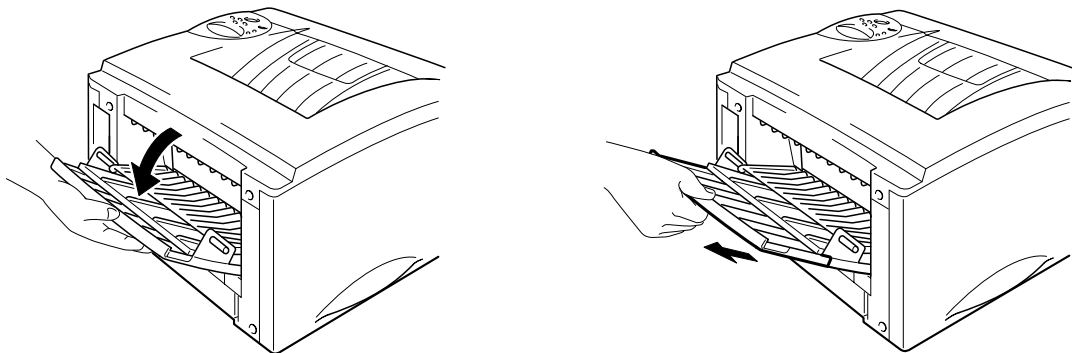

Fig. 1-20

4. Place envelopes, with the side to be printed on face up, in the Multi-purpose tray so they touch the back of the tray and remain below the limit mark.

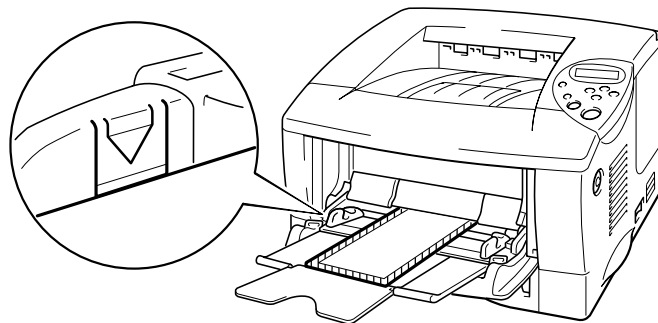
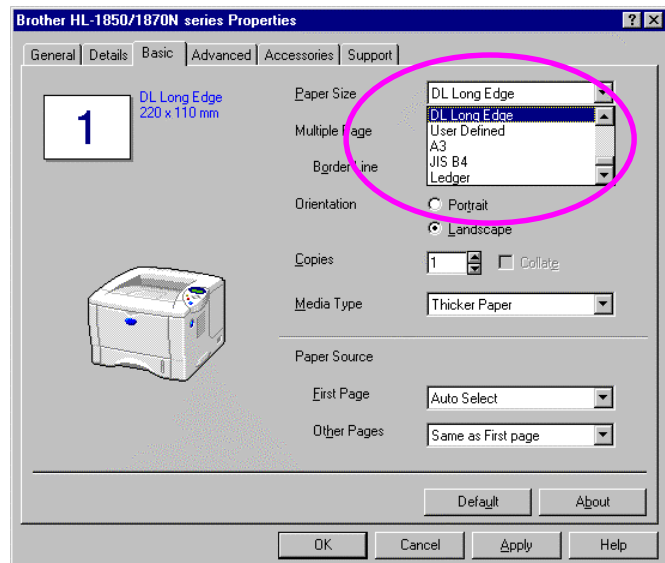
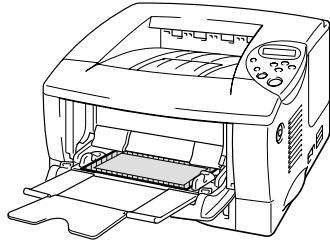

Fig. 1-21

Note

If DL size double-flap envelopes were creased after they have been printed, put in new DL size double-flap envelopes sideways, and print again.

**Note**

When you place paper in the Multi-purpose Tray, note the following:

- If you will be printing on paper that weighs more than 135 g/m² (36 lbs), use the Face Up Output Tray.
- Insert the leading edge of the paper first and push it gently into the tray.
- The top of the paper stack must be under the guides that are on both sides of the tray. The maximum thickness is 11 mm (or 0.43 inch).

5. Press and slide the paper width adjuster to fit the envelope size.

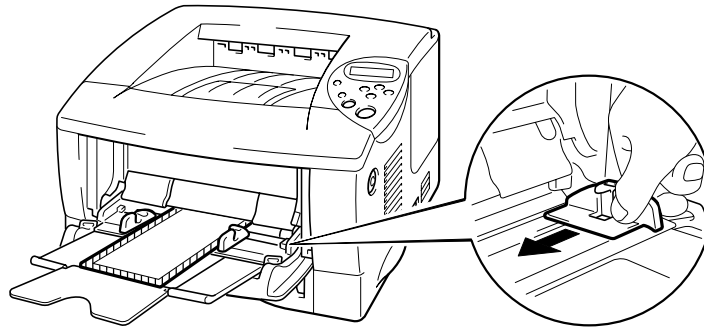

Fig. 1-21

• Note

-
- Make sure that neatly stacked envelopes are correctly seated in the Multi-purpose Tray; otherwise, envelopes may not be fed correctly, resulting in skewed printouts or paper jams.
-

6. Select the driver setting as follows:

| Paper Size | Media | Paper Source |
|---------------|--|--------------|
| Envelope Size | Envelopes Envelopes-Thin Envelopes-Thick | MP tray |

Printing on Labels and Transparencies

- Do not use damaged, curled, wrinkled, or irregularly shaped paper.
- Do not use labels without a mount.
- We recommend that you use labels and transparencies that are made for laser printers.
- Use labels and transparencies that can withstand intense heat; the interior of the printer reaches very high temperatures while printing.

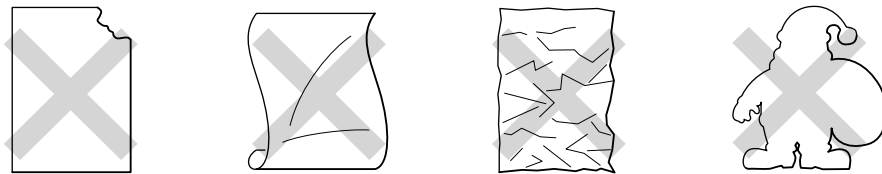

Fig. 1-22

•• Note

-
- Before using paper with holes, such as organizer sheets, you must fan the stack of paper well to avoid paper jams and misfeeds.



- Do not place the punched holes of organizer sheets near the actuator (paper sensor).
 - Do not use organizer sheets that are stuck together. The glue on them might cause damage to the printer.
 - Do not load different types of paper at the same time in the paper cassette because this may cause paper jams or misfeeds.
 - For correct printing, you must select the same paper size from within your software application as the paper in the tray.
 - If your application software does not support paper size selection in its Print menu, you can change the paper size by using the paper menu on the printer control panel. [For more information, see Chapter 3.](#)
-



Warning

Do not touch transparencies that have just been printed because they are very hot!

1. Open the Multi-purpose Tray.
2. Unfold the Multi-purpose Tray Extension.

When you use labels, open the Face Up Output Tray.
When you use transparencies, print to the Face Down Output Tray.

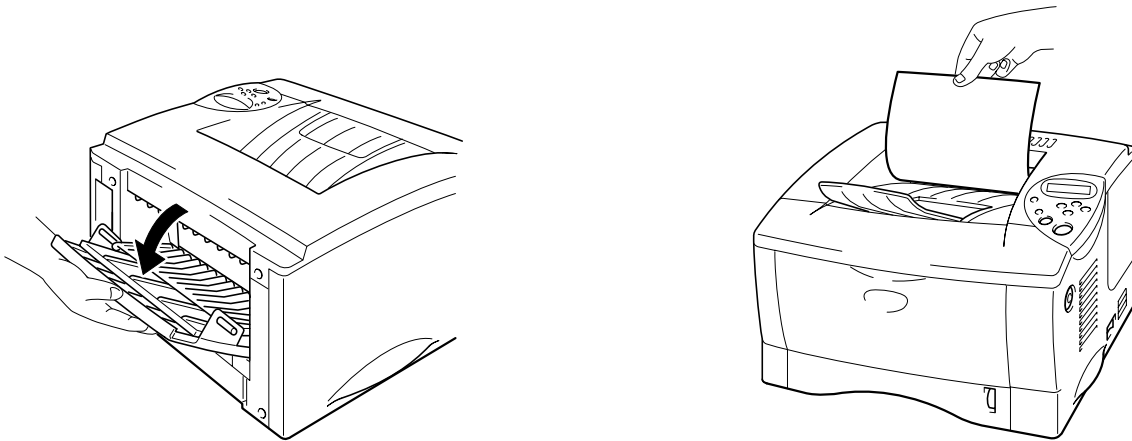

Fig. 1-23

3. Place paper with the side to be printed on face up in the Multi-purpose Tray so it touches the back of the tray and remains below the limit mark.

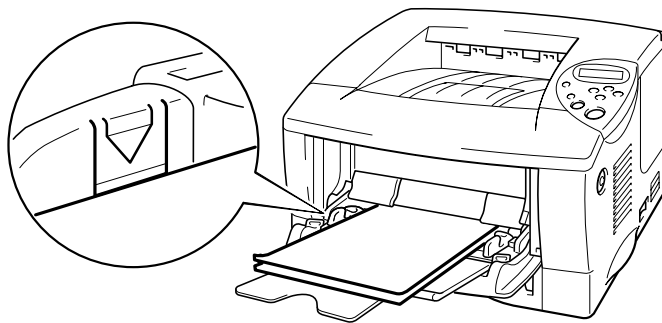

Fig. 1-24

Note

When you place paper in the Multi-purpose Tray, note the following:

- If you will be printing on paper that weighs more than 135 g/m² (36 lbs), use the face up output tray.
- Insert the leading edge of the paper first and push it gently into the tray.

4. Press and slide the Paper Width Adjuster on the right-hand side to fit the paper.

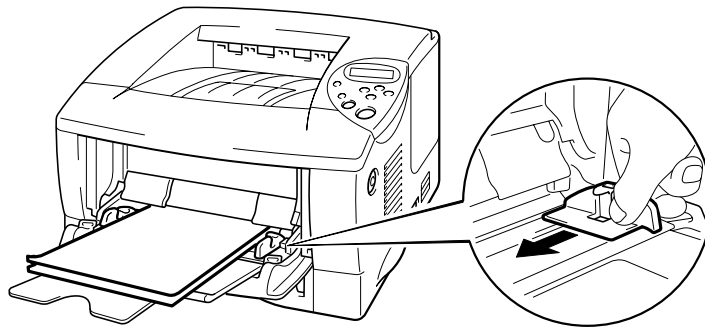

Fig. 1-25

5. Select the driver settings as follows:

| To be printed on | Paper Size | Media | Paper Source |
|------------------|--------------|----------------|-------------------|
| Transparencies | A4 Letter | Transparencies | Tray 1 MP tray |
| Labels | A4 Letter | Thick paper | MP tray |

Printing on Both Sides of the Paper (Duplex printing)

Guidelines for printing on both sides of the paper:

- If the paper is thin, it may wrinkle.
- If paper is curled, straighten it, and then place it in the paper cassette.
- Use A4, Letter or Legal size plain paper (60 to 105 g/m² or 16 to 28 lb.). Do not use bond paper.
- If the paper is not feeding correctly, it may be curled. Remove the paper and straighten it.

☛ 1. Load paper into the Paper Cassette or Multi-purpose Tray.

☛ 2. When you use A4 or Letter size paper, set the Paper Adjustment Lever for Duplex Printing to match your paper size.

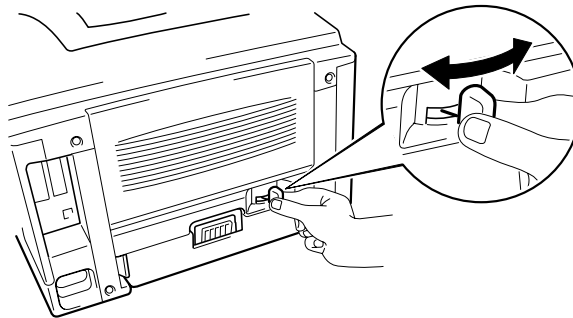

Fig. 1-26

•➡ Note

If the Paper Adjustment Lever for Duplex Printing is not correctly set for the paper size, paper jams may occur and the print will be out of position on the paper.

3. For Windows User

Open the Properties dialog box in the printer driver. Select Duplex Printing mode in the Advanced tab, make sure that 'Use Duplex Unit' has been selected, and then click the OK button. The printer will print on both sides of the paper automatically.

<PCL driver>

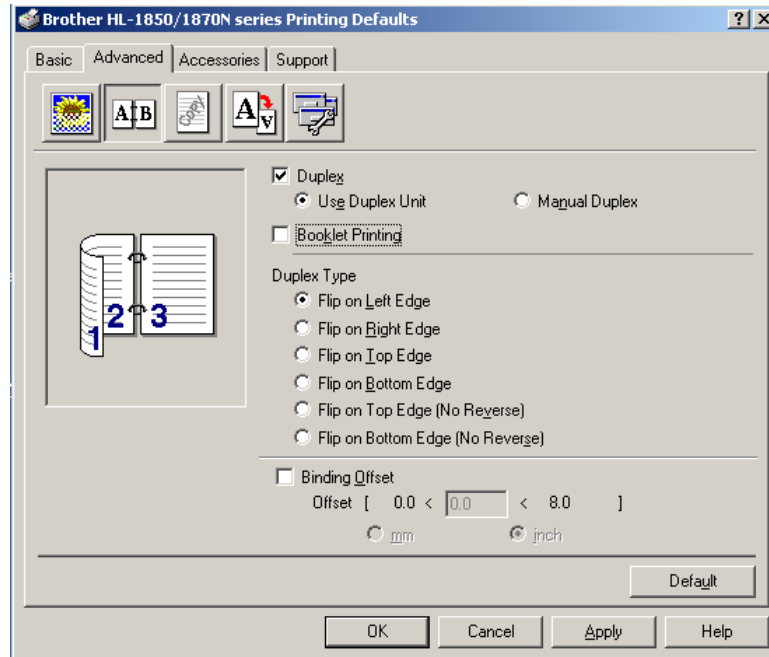

<PS driver>

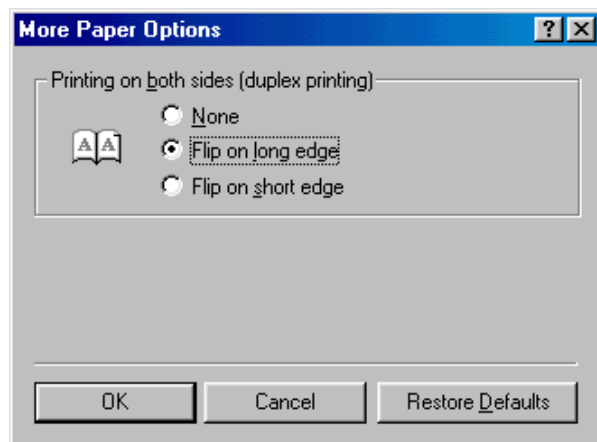
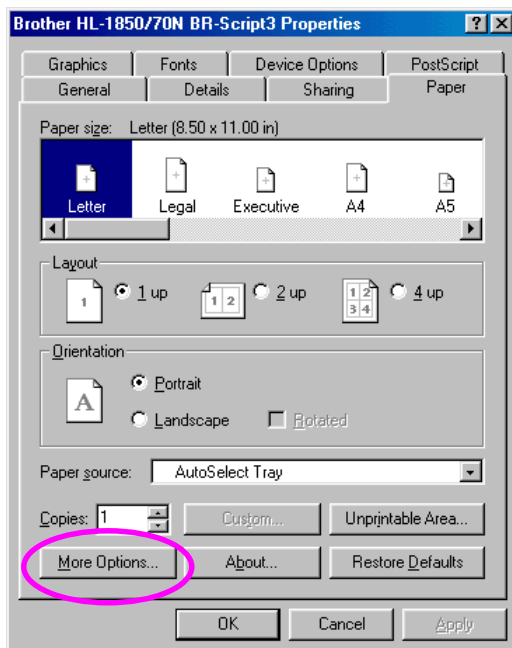

For Macintosh user

Change the Pages per sheet setting in Layout.

1. Click the 'File' menu, and then select the 'Print' option. You will see a dialogue similar to the one below:
2. Click the "General" drop down box. You will see a drop down list with the following options:

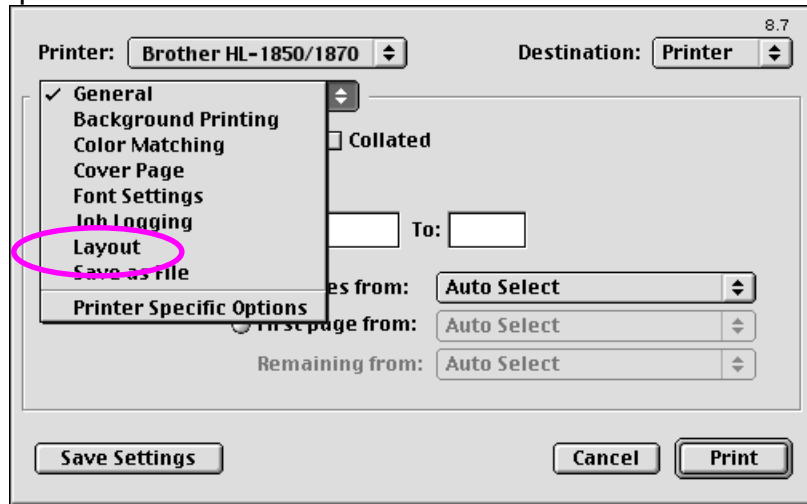

3. Once on the layout page you can enable duplex by selecting the "Print on Both Sides" checkbox.

From here you have the choice to select either long or short edge duplexing. Select the option you require for your print job. See the image below.

From here you have the choice to select the Pages per sheet, Layout direction and Border. Select the option you require for your print job. See the image below.

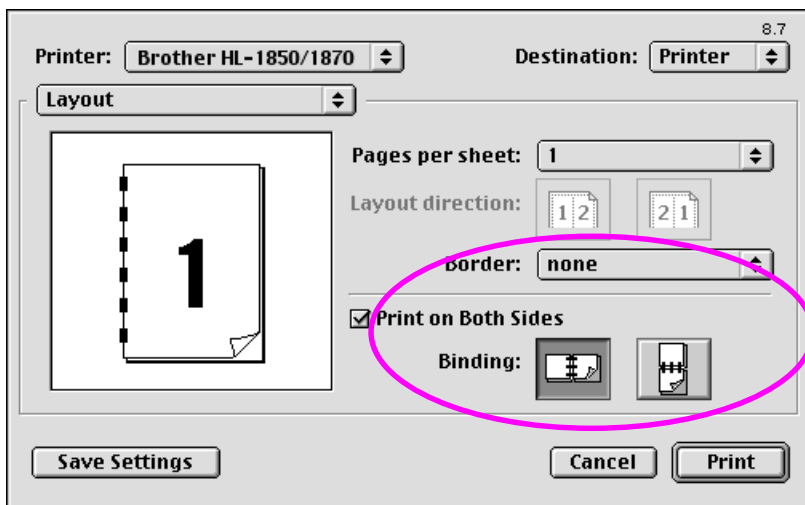

Booklet Printing (For PCL Driver Only)

The supplied printer drivers for Windows® 95 / 98 / Me, Windows NT® 4.0 and Windows® 2000/XP support booklet printing.

Guidelines for Booklet Printing

- If the paper is thin, it may wrinkle.
- If paper is curled, straighten it, and then place it in the paper cassette.
- Use A4 or Letter size plain paper (60 to 105 g/m² or 16 to 28 lb.). Do not use bond paper.
- If the paper is not feeding correctly, it may be curled. Remove the paper and straighten it.

☛ 1. Load paper into the Paper Cassette or Multi-purpose Tray.

☛ 2. When you use A4 or Letter size paper, set the Paper Adjustment Lever for Duplex Printing to match your paper size.

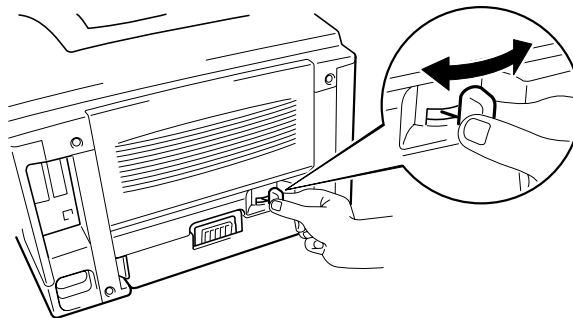
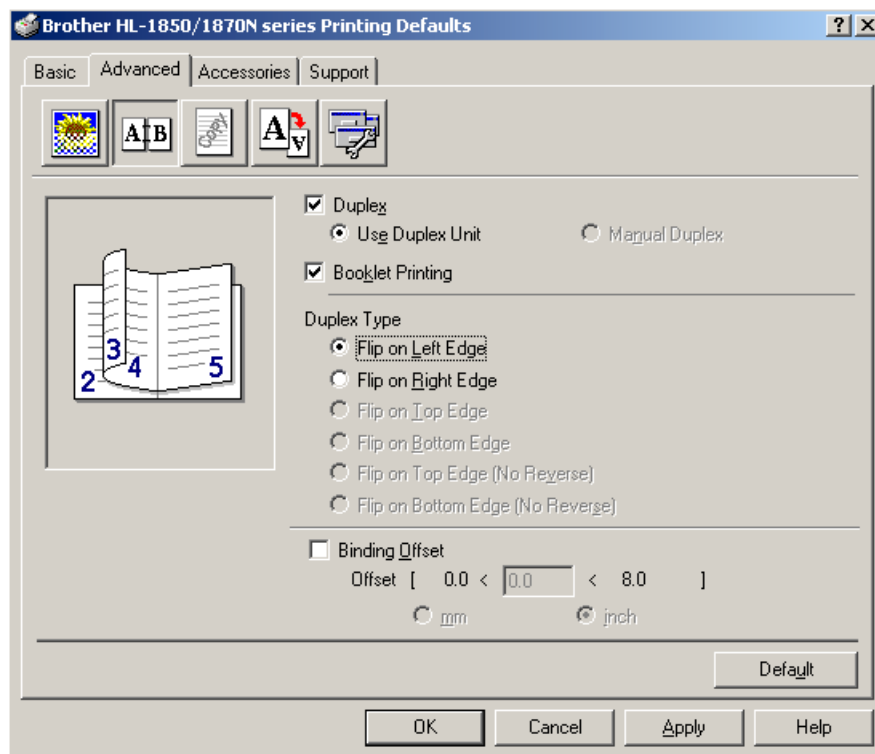

Fig. 1-27

❖ Note

If the Paper Adjustment Lever for Duplex Printing is not correctly set for the paper size, paper jams may occur and the print will be out of position on the paper.

3. Open the Properties dialog box in the printer driver. After you check the Duplex function in the Advanced tab, check the Booklet Printing function. Select the Duplex mode. The printer will print a Booklet automatically.



Manual Feed

If you place paper in the Multi-purpose Tray and the setting MANUAL FEED = ON has been set in the PAPER mode from the control panel, the printer will load paper only from the Multi-purpose Tray.

•♦ Note

When you feed paper manually, note the following:

- If your application software supports a manual feed selection in the Print menu, you can select it in that software. The software command setting overrides the control panel's setting. You will not have to set MANUAL FEED and MP SIZE in the PAPER mode.
 - If you use pre-printed paper in the Multi-purpose Tray, the paper should be inserted top edge first with the pre-printed side face up.
-

CHAPTER 2

DRIVER AND SOFTWARE

Printer Driver

A Printer Driver is software that translates data from the format used by a computer into the format required by a particular printer. Typically, this is done using a printer command language or page description language.

The printer drivers for the following operating systems are on the CD-ROM that we have supplied. You can also download the latest printer driver from the Brother Solutions Center at <http://solutions.brother.com>.

| | PCL Driver (Hewlett-Packard LaserJet laser printer) | BR-Script Driver (Postscript Level3 language emulation) |
|--|---|---|
| Windows® 95/98/Me | ✓ | ✓ |
| Windows® 2000 | ✓ | ✓ |
| Windows NT® 4.0 | ✓ | ✓ |
| Windows® XP | ✓ | ✓ |
| | | BR-Script Driver (PostScript Level3 language emulation) |
| Mac OS 8.6-9.2 *Use the LaserWriter 8 Driver that we have supplied for your OS | ✓ | |
| Mac OS X 10.1 *Use the PostScript Driver that we have supplied for your OS | ✓ | |

-
- If you want to print from a DOS application, [please see Chapter 6](#).
 - When you print using a Network, you will need to have the Network board installed. [Please see Chapter 4](#).
-

Features in the PCL Printer Driver (Windows® Users Only)

You can download the latest driver or get other product information by accessing the Brother Solutions Center at <http://solutions.brother.com>
You can also change settings by clicking the illustration on the left side of the tab screen.

❖ Basic Tab

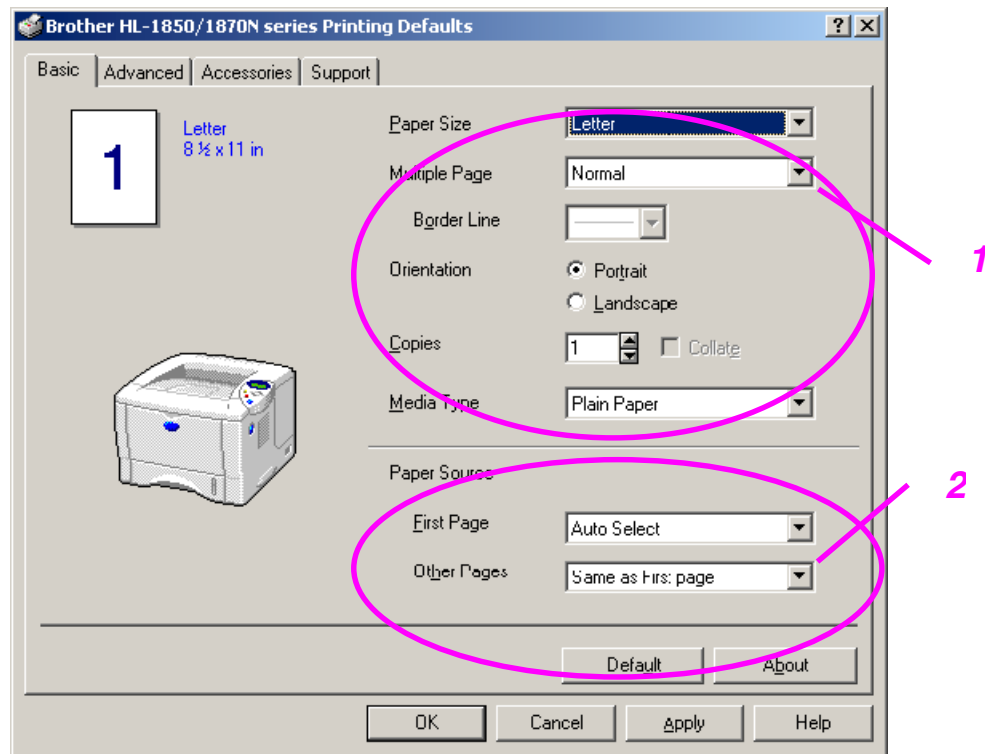

- 1 Select the Paper size, Multi-page, Orientation, Copies and Media Type.
- 2 Select the Paper Source.

❖ **Advanced Tab**

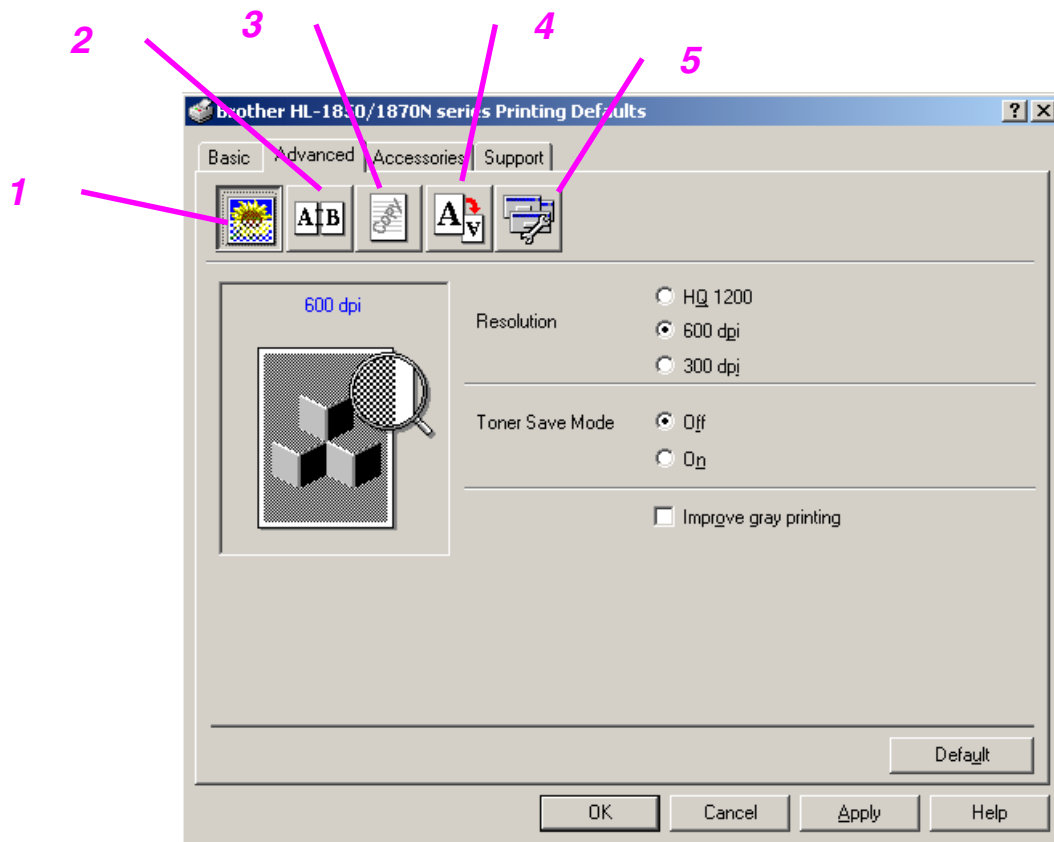

Change the tab settings by pressing these icons as follows:

1. Print Quality
2. Duplex / Booklet Printing
3. Watermark
4. Page Setting
5. Device Options

◆ **Print Quality**

Select the Resolution, Toner Save and Print Setting and so on.

- You can change the resolution as follows:
300 dpi
600 dpi
HQ1200: Brother HQ1200 technology provides the best print quality while printing at full engine speed.
- Toner Save Mode
You can save running costs by turning on the Toner Save mode, which reduces the print density.
- Print Setting (Windows® 95/98/98SE/ME users only)
With the Print Setting set to MANUAL, you can change the Brightness, Contrast, Graphics mode settings and TrueType mode options.

◆ **Duplex Printing**

This printer has a Duplex Printing function as standard. If you select the Duplex icon, the dialogue box for duplex settings will appear. There are six types of duplex options available for each orientation.

◆ **Booklet Printing (For PCL driver Only)**

This printer has a Booklet Printing function as standard. If you select the Duplex icon, the dialogue box for duplex settings will appear, so you can select from 2 types of booklet options.

◆ **Watermark**

You can put a watermark logo or text into your documents.

When you use a bitmap file as a watermark, you can change the size of the watermark and put it anywhere you like on the page.

When you use text as a watermark, you can change the font, darkness and angle settings.

◆ **Page Setting**

Change the print image scaling and select Mirror / Reverse print options.

◆ Device Options

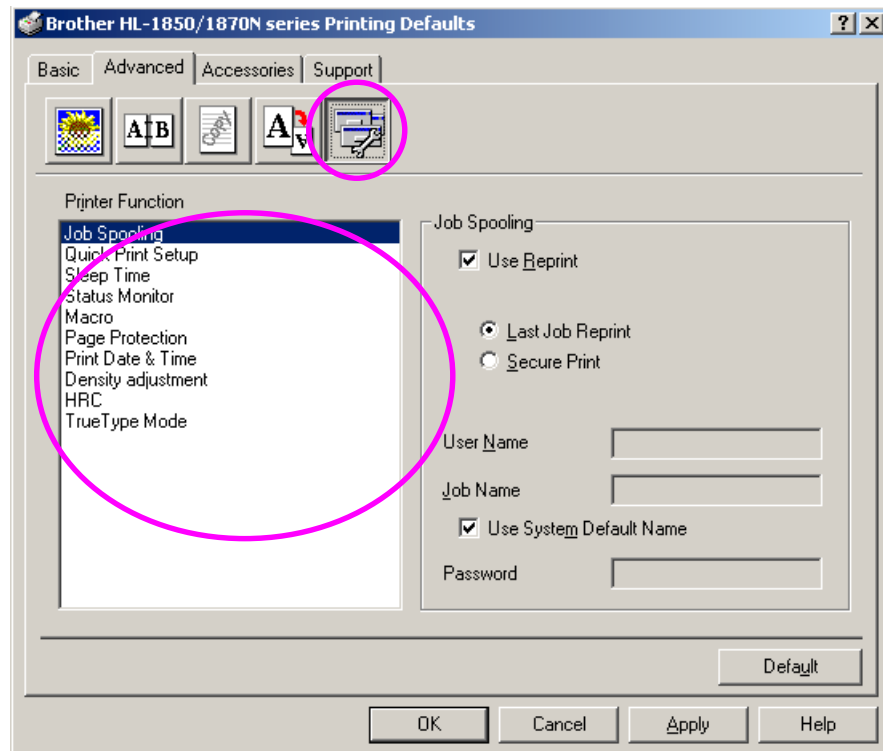

You can the following Print Function modes in this tab.

- Job Spooling
- Quick Print Setup
- Sleep Time
- Status Monitor
- Macro s
- Administrator (Windows® 95/98/98SE/ME users only)
- Insert Command File
- Page Protection
- Print Date & Time
- HRC
- TrueType Mode

◆ **Job Spooling**

You can reprint a document without sending the data again from your PC because the printer will save data that you specify for reprinting.

- Last Job Reprint: Reprint the last job
- Secure Print: Print the data with a password

For more information about the Reprint function, see “REPRINT button” in Chapter 3.

•♦ **Note**

If you want to prevent other people from printing your own data using the Reprint function, remove the Use Reprint check mark in the Job Spooling settings.

❖ Accessories

When you install the optional units, you can add those options and select their settings in the Accessories tab as follows.

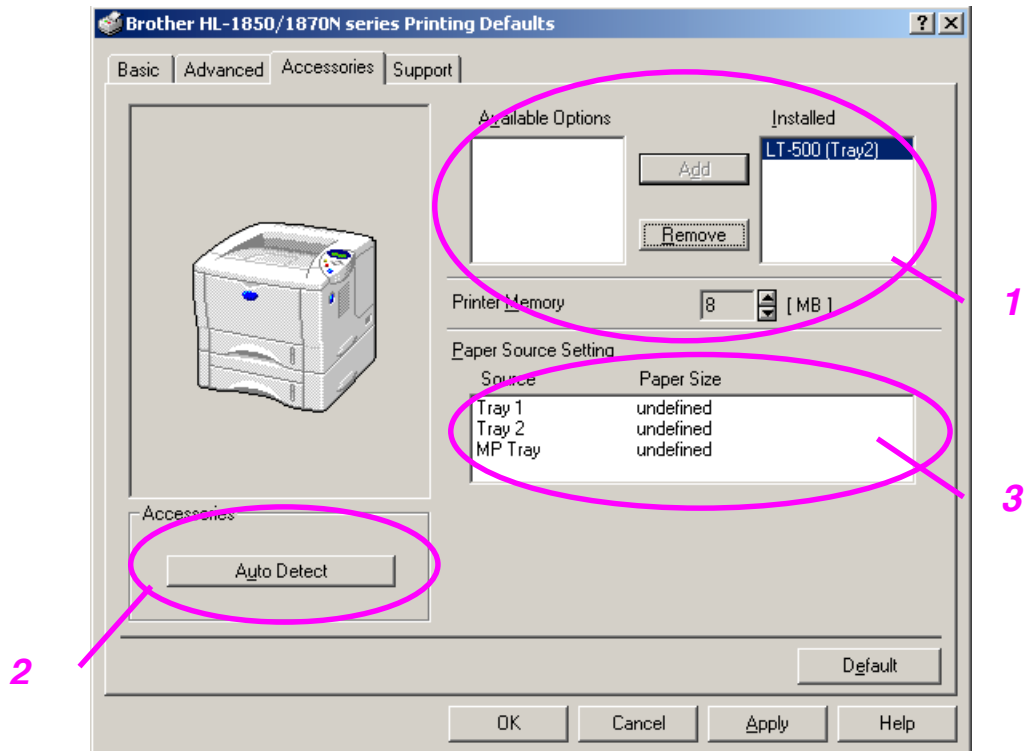

1 You can add and remove the optional units manually.

2 Auto Detect (Automatically Detect the Optional units)

This function detects the optional devices that have been installed. The available functions are reflected in the printer driver.

When you press “Auto Detect”, options that are installed on the printer will be listed. You can manually add or delete options. Tray and other settings will match the installed options.

↔ Note

Auto Detect function is not available according to printer status and printer condition.

3 Paper Source Setting

“Auto Detect function” recognises the size of paper in each paper tray.

❖ Support Tab

- You can download the latest driver or get other product information by accessing the Brother Solutions Center at <http://solutions.brother.com>
- You can see the printer driver version.
- You can check the current driver settings.
- You can print the Configuration page, Test page, and so on.



Features in the PS Printer Driver (Windows® Users Only)

You can download the latest driver or get other product information by accessing the Brother Solutions Center at <http://solutions.brother.com>

•⇨ **Note**

The screens shown in this section are from Windows® 98. The screens on on your PC vary depending on your Windows® Operating System.

❖ **Details Tab**

Choose the port where your printer is connected or the path to the network printer you are using.
Choose the printer driver that you have installed.

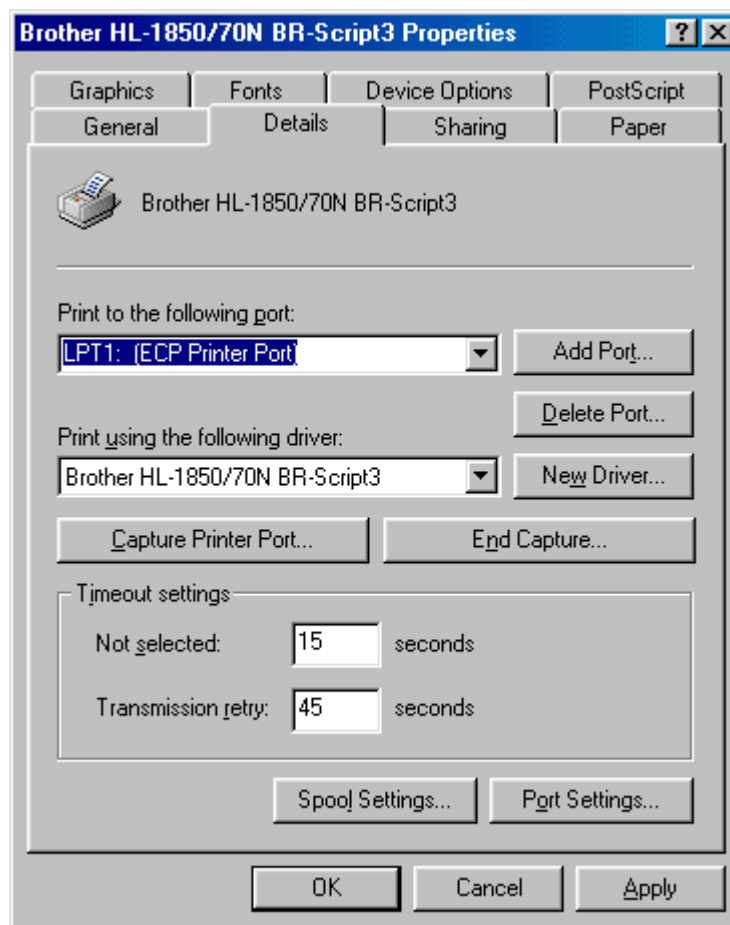

❖ Paper Tab

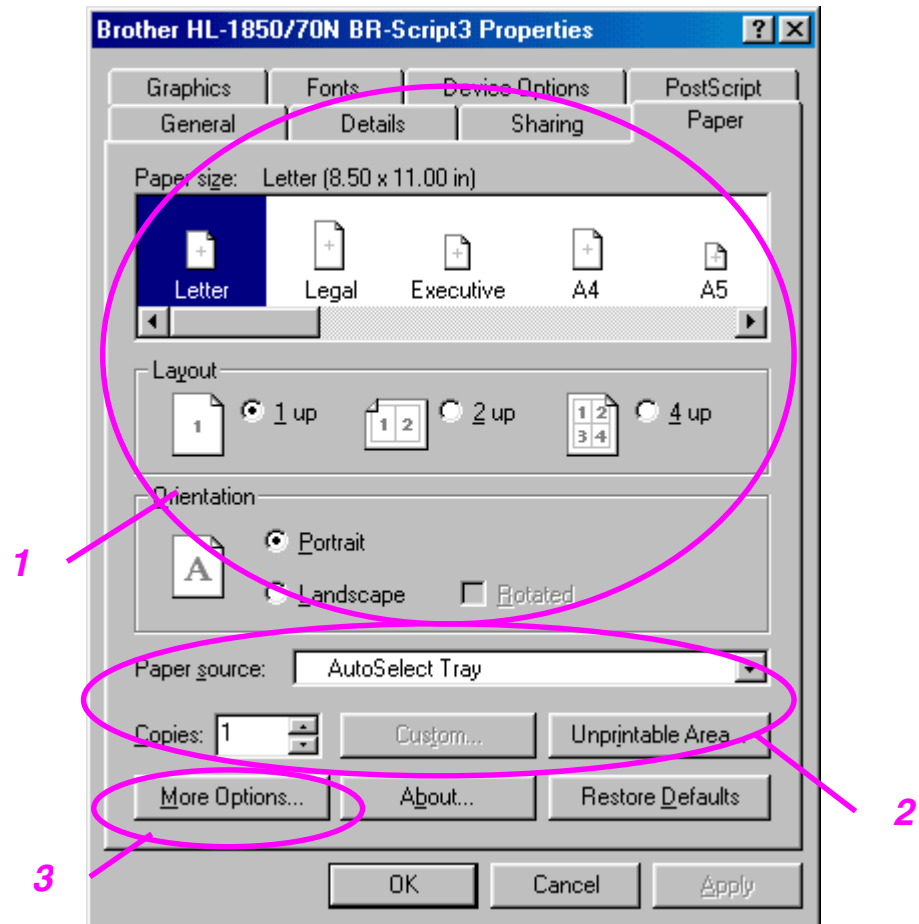

- 1 Select the Paper size, Layout and Orientation.
- 2 Select the Paper source.
- 3 Select the Duplex function.

❖ Graphics

Set the Resolution, and so on.

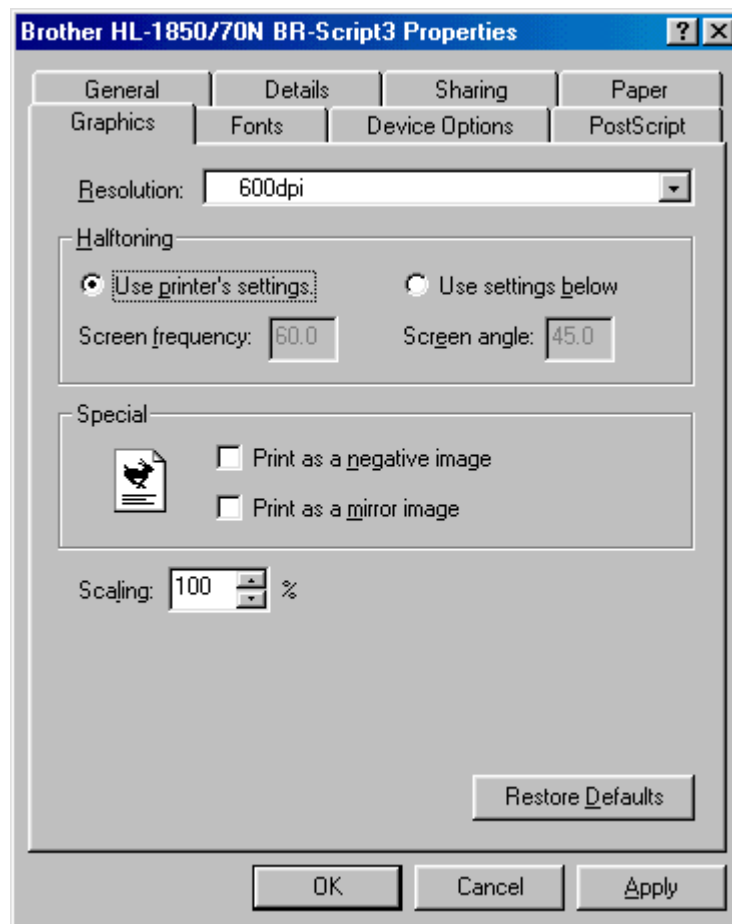

❖ Device Options

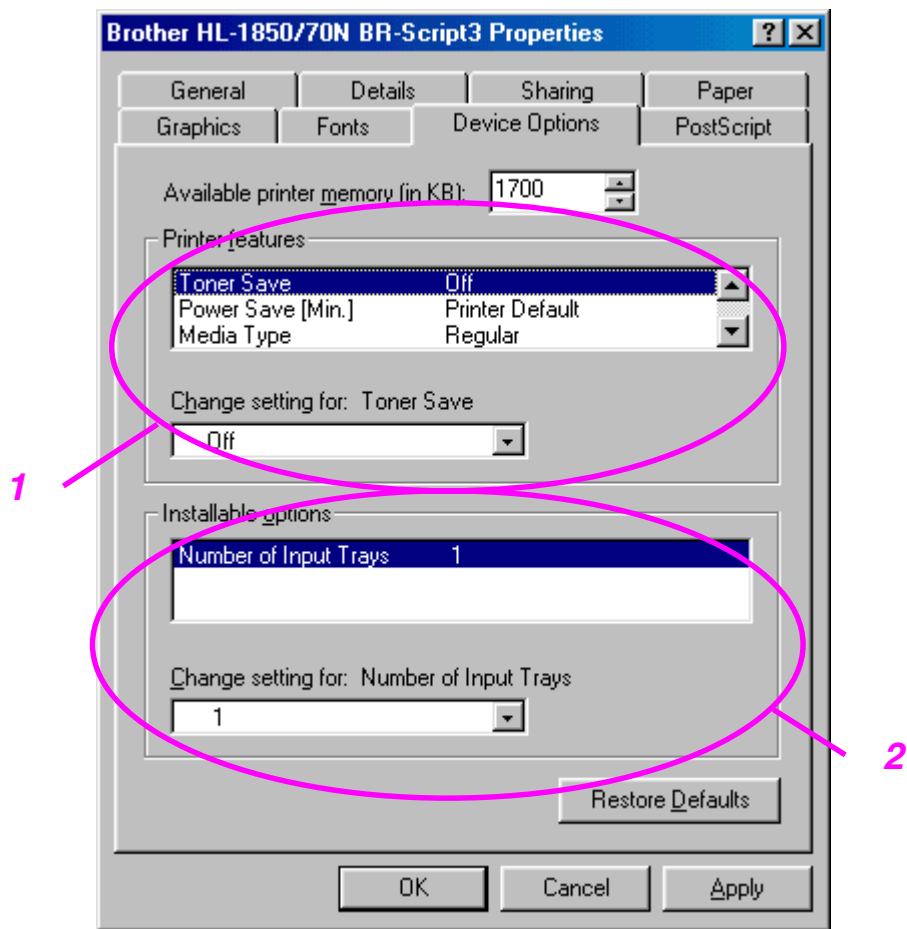

- 1 You can change settings by clicking on the setting and then choosing a new value in the Change setting for box.

Toner Save Mode

Sleep Mode

Media Type

HRC setting

Job spooling (You need to set the RAM Disk size first. [For more information, see Chapter 3.](#))

- 2 Select the installed options from the list.

Features in the PS Printer Driver (Mac OS® 8.6 to 9.2/Mac OS® X 10.1 only)

You can download the latest driver or get other product information by accessing the Brother Solutions Center at <http://solutions.brother.com>

❖ Page Setup

You can set the Paper size, Orientation and Scale.

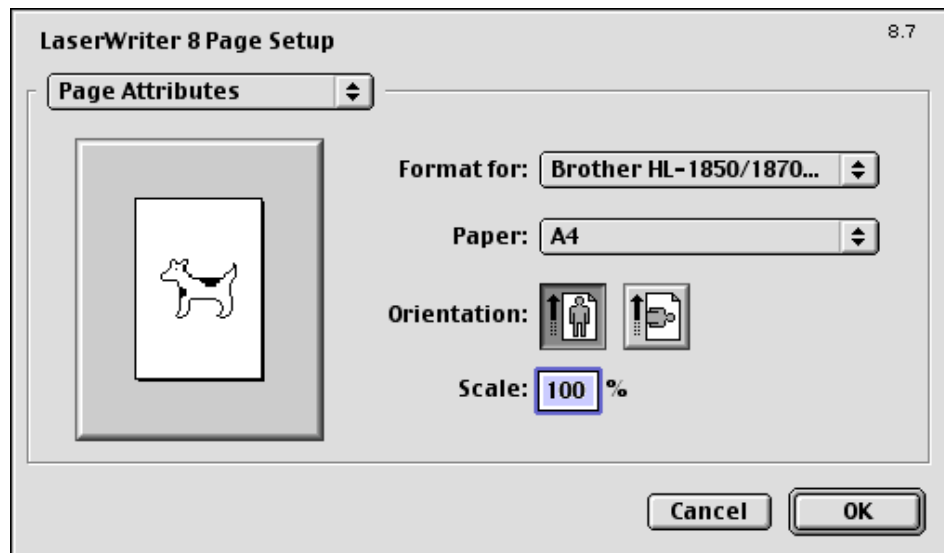

❖ Layout

Set the layout, and so on.

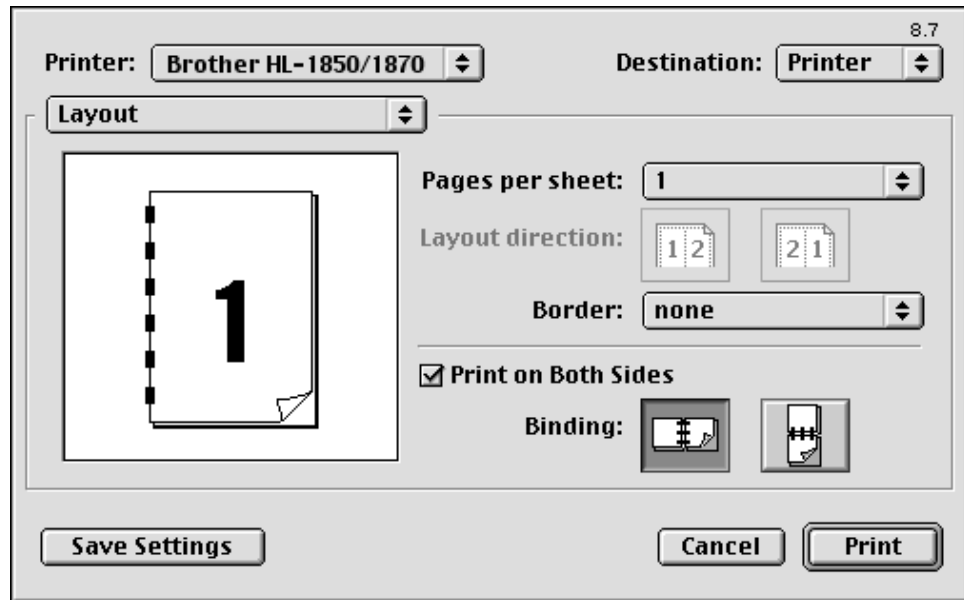

❖ *Specific Options*

Set the Media Type, Resolution, secure printing, and so on.

The image shows a printer settings dialog box with the following fields and options:

- Printer:** Brother HL-1850/1870N se... (dropdown)
- Destination:** Printer (dropdown)
- Printer Specific Options:** (dropdown menu)
- Media Type:** Regular (dropdown)
- Resolution:** 600dpi (dropdown)
- HRC:** Printer Default (dropdown)
- Job Spooling:** Off (dropdown)
- Password:** None (dropdown)
- User Name:** System Name (dropdown)
- Job Name:** System Name (dropdown)

Buttons at the bottom: Save Settings, Cancel, Print.

Version number: 8.7

Software for Networks

◆ **Web Browser Management**

Many Brother printers support Embedded Web Server (EWS) technology. This means that you can use a standard web browser to manage many aspects of the printer; for example, you can view consumable life, configure network parameters, view serial number information, printer usage, and so on. Start your web browser and enter the NetBIOS name, DNS name or IP address of the printer.

(Windows® Users Only)

◆ **BRAdmin professional**

The BRAdmin Professional software is designed to manage your Brother network connected devices. For example, Brother network ready printers and Brother network ready Multifunction devices can be managed using the BRAdmin Professional software. The BRAdmin Professional software can also be used to manage devices from other manufacturers whose products support the SNMP (Simple Network Management Protocol).

◆ **Storage Manager**

Brother Storage Manager software can manipulate the printer forms that you may have stored in the internal flash memory.

You can print the fixed form document at any time from the control panel.

To make the fixed documents print, you must first write Fonts, Macros or fixed forms to the memory of your printer.

◆ **Driver Deployment Wizard**

This installer includes the Windows PCL driver and Brother network port driver (LPR and NetBIOS). The administrator should set up the IP address, Gateway and Subnet with BRAdmin Professional before using this software. If the administrator then installs the printer driver and port driver using this software, he can save the file to the File server or send the file in E-mail to users. Then, each user just clicks that file to have the printer driver, port driver, IP address, and so on, automatically copied to their PC.

Software installation for Windows Computers

You can install the Software from the CD-ROM that we have supplied as follows:

- 1.** Insert the CD-ROM into the CD-ROM drive. The opening screen appears automatically.

If the screen does not appear, click Start and choose Run, enter the CD - drive letter and type \START.EXE (for example: D:\START.EXE).

- 2.** Select the LANGUAGE, and then follow the on-screen instructions. The printer driver will complete the installation.

Software Installation for Macintosh Computers

This printer supports Mac OS 8.6 to 9.2 and Mac OS X 10.1

❖ Apple LaserWriter 8 Driver

The Apple LaserWriter Driver may have been installed with your system. It is also available at <http://www.apple.com>
LaserWriter 8 versions 8.6 and 8.7 have been tested for use with this printer.

❖ PostScript Printer Description Files (PPDs)

PPDs, in combination with the Apple LaserWriter 8 Driver, access the printer features and allow the computer to communicate with the printer. An installation program for the PPDs (“BR-Script PPD Installer”) is provided on the CD-ROM.

Automatic Emulation Selection

This printer has an Automatic Emulation Selection function. When the printer receives information from the computer, it automatically chooses the emulation mode. This function has been set at the factory to ON.

The printer can select among the following emulation combinations:

| EPSON (default) | IBM |
|------------------------|-------------------|
| HP LaserJet | HP LaserJet |
| BR-Script 3 | BR-Script 3 |
| EPSON FX-850 | IBM Proprinter XL |

You can choose the emulation mode manually by using the EMULATION menu in the SETUP mode on the printer control panel. [For more information, see Chapter 3.](#)

•• Note

When you use the Automatic Emulation Selection, note the following:

- The EPSON or IBM emulation mode priority must be selected because the printer cannot distinguish between them. Since the factory setting is EPSON emulation mode, so to use the IBM emulation mode you will need to select it by using the EMULATION menu in the SETUP mode on the printer control panel.
 - Try this function with your application software or network server. If the function does not work properly, either select the required emulation mode manually using the printer panel buttons or use the emulation selection commands in your software.
-

Automatic Interface Selection

This printer has an Automatic Interface Selection function. When the printer receives data from the computer, it automatically selects the interface that is appropriate.

When you use the parallel interface, you can turn the high-speed and bi-directional parallel communications on or off by using the Parallel menu in the INTERFACE mode on the printer control panel. **For more information, see Chapter 3.** Since the Automatic Interface Selection mode has been set at the factory to ON, simply connect the interface cable to the printer.

If a Network board (Brother NC-4100h) has been installed, select NETWORK mode on the printer control panel.

If you constantly use only one interface, we recommend that you select that interface in the Interface mode. The printer allocates all of the input buffer to that interface if only one interface is selected.

Printer Settings

Factory Settings

The printer settings have been set at the factory before shipment. They are called “Factory Settings.” Although you can operate the printer with these factory settings unchanged, you can tailor the printer with user settings.

Please see “List of Factory Settings” in Chapter 3.

⇒ Note

Changing the user settings does not affect factory settings. You cannot modify the preset factory settings.

The changed user settings can be restored to the factory default settings with the RESET MENU mode. For more information, see Chapter 3.

CHAPTER 3

CONTROL PANEL

Control Panel

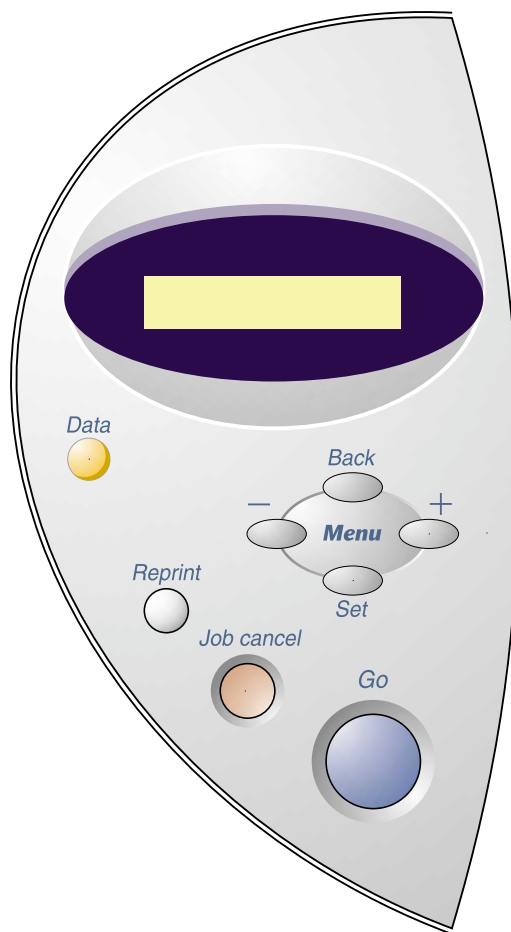

Fig. 3-1

Buttons

You can control the basic print operations and change the printer settings with the seven buttons on the control panel (**Go**, **Job Cancel**, **Reprint**, **+**, **-**, **Set**, **Back**).

| | Button | Function |
|---|-------------------|--|
| 1 | Go | Exit from the Control panel menu, Reprint settings and Error messages. Pause / Continue printing. |
| 2 | Job Cancel | Stop and cancel the printer operation in progress. |
| 3 | Reprint | Set the Reprint menu. |
| 4 | + | Move forward and backward through menus. |
| | - | Move forward and backward through selectable options. |
| 5 | Set | Select the displayed menu. Set the selected menus and settings. |
| 6 | Back | Go back one level in the menu structure. |

Go Button

Press the **Go** button once to return the printer status to “READY” from the current settings (MENU, ERROR and REPRINT). For ERROR indications, the control panel changes only when the error is cleared.

You can “PAUSE” printing with the **Go** button. If you press the **Go** button again you restart the print job and clear the PAUSE. During PAUSE, the printer is in the off-line state.

↔ Note

If you do not wish to print the remaining data when the printer is in PAUSE, you can cancel the job by pressing the **Job Cancel** button. Then, press the **Go** button to clear the PAUSE and return the printer to the “READY” state.

Job Cancel Button

You can cancel the processing or printing of data with the **Job Cancel** button. The display shows “JOB CANCELLING” until cancelling is completed. After cancelling the job, the printer returns to the “READY” state.

When the printer is in any state except receiving data or printing, the display shows “NO DATA!!!” and you cannot cancel the job.

Reprint Button

If you want to reprint a document that has just been printed, you can reprint it by pressing the **Reprint** button.

When you want to print SECURE data, we recommend that you use RAM enhancement to enable you to reprint using the RAM function.

When you use RAM to reprint;

1. Press the **Set** button on the Control panel to exit from the READY status and select RAMDISK SIZE in the SETUP mode.
2. The default RAM size is 0MB. Press the + button to increase the reprint RAM size in 1MB steps.

↔ Note

When you increase the RAM size for secure printing, the work area of the printer is decreased and printer performance will be reduced. When you store data in RAM, the data will be deleted when the printer power is turned off.

We also recommend adding additional RAM if you want to be able to print a large amount of secured data. (See [RAM Expansion in Chapter 4.](#))

❖ **Reprinting the Last JOB**

You can reprint the last print job without sending it from the computer again.

•• **Note**

-
- When REPRINT is set to OFF using the control panel and you press the **Reprint** button, the LCD briefly shows “NO DATA STORED.”
 - If you want to cancel reprinting, press the **Job Cancel** button.
 - If the printer does not have enough memory to spool the print job, it will print only the last page.
 - Pressing the – or + button increases or decreases the number of copies to be reprinted. You can select between COPIES= 1 and COPIES=999.
 - For more information about the settings in the printer driver, see “[Job Spooling](#)” in [Chapter 2](#).
-

◆ Reprint the Last JOB 3 Times

↔ Note

If you print using the printer's own driver, the settings for Job Spooling in the printer driver will take priority over the settings made on the printer control panel. For more information, see "Job Spooling" in Chapter 2.

- ☛ 1. Press the **Reprint** button.

COPIES= 1



Press + until the number of copies is displayed.

COPIES= 3



Press the **Set** or **Reprint** button.

PRINTING

↔ Note

-
- If you wait too long to continue pressing the buttons on the control panel, the display exits the REPRINT menu.
 - If you want to reprint the data and have pressed the **Go** button, the display shows "PRESS SET TO PRINT." Press **Set** to start the reprint job or press the **Go** button to cancel the reprint job.
-

❖ **Printing *SECURE* Data**

Secure documents are password protected. Only those people that know the password will be able to print the document. The printer will not print the document when you send it for printing; to print the document you must use the control panel of the printer.

When you want to delete the spooled data, you can carry out this operation on the control panel.

•• **Note**

-
- If there is data in the job information that cannot be displayed on the LCD, the display shows “?”.
 - You can reprint the job using the supplied printer driver. **For more information about the settings in the printer driver, see “Job Spooling” in Chapter 2.**
-

◆ Operations for Printing Secure Data

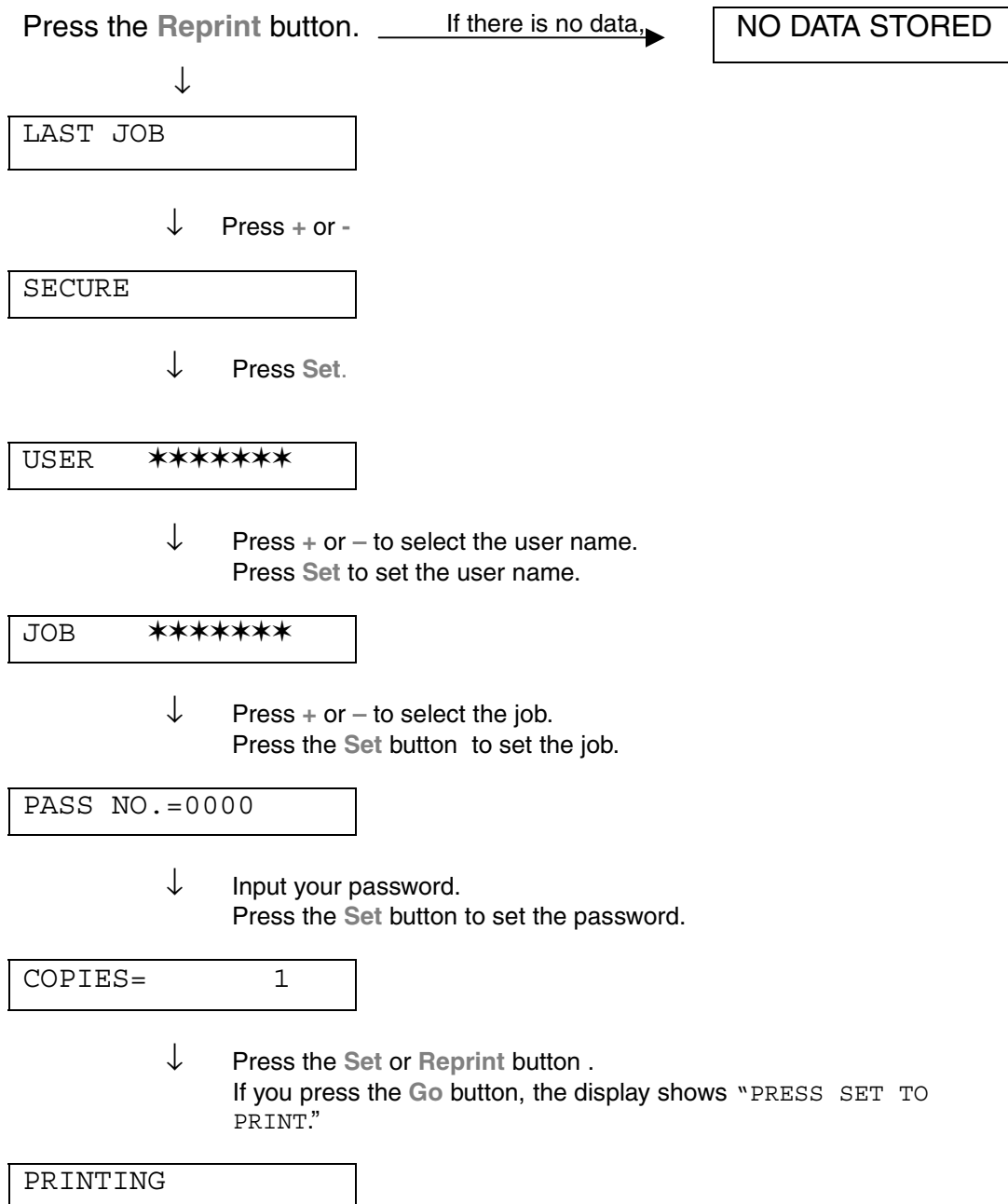

◆ ***When There Is No Reprint Data in Memory***

If the printer does not have any data in buffer memory and you press the **Reprint** button, the LCD briefly shows “NO DATA STORED.”

◆ ***When You Cancel the Reprint Job***

Pressing the **Job Cancel** button allows you to cancel the reprint job. The **Job Cancel** button also allows you to cancel a paused reprint job.

Menu (+ / – / Set / Back) Button

If you press the + or – button when the printer is in the on-line state (READY), it goes off-line and the LCD displays the current mode.

❖ + / – Button

Pressing the + or – button allows you to scroll forward or backward through the menus and settings on the display. Press or hold the button until the display shows the item you want.

There are two ways to input numbers.

You can press the + or – button to scroll up or down to set one number at a time, or you can hold down the + or – button to scroll faster. When you see the number you want, press the **Set** button.

❖ **Set Button**

Pressing the **Set** button allows you to set the selected menu or the default number. After you change the menu or number, an asterisk will appear briefly on the right side of the message and the mode will return to the previous menu.

❖ **Back Button**

Press the **Back** button to return to the previous level from the current menu level. The **Back** button allows you to select the previous digit while inputting numbers. When the leftmost digit is selected, the **Back** button allows you to go up one level in the menu. When a menu or number without an asterisk (**Set** button not pressed) is selected, the **Back** button allows you to return to the previous menu level with the original setting unchanged.

❖ **Note**

When you press the **Set** button to select a setting, * (an asterisk) appears briefly at the end of the display. Since the asterisk indicates the selection, you can easily find the current settings as you scroll through the display.

LED

The lamps light or blink to indicate the current printer status.

❖ **DATA - Orange LED**

| LED indication | Meaning |
|----------------|-------------------------------------|
| On | Data remains in the printer buffer. |
| Blinking | Receiving or processing data |
| Off | No remaining data |

LCD Display

The display shows the printer status. When you use the control panel buttons, the display will change.

If any problems occur, the display shows the error message to prompt you to take action. [For more information about these messages, see “TROUBLESHOOTING” in Chapter 6.](#)

BACK LIGHTS

| | |
|------------------|--|
| Off | The printer is in Sleep status. |
| Green (General) | Warming up |
| | Ready to print |
| | Printing |
| Red (Error) | A problem has occurred with the printer. |
| Orange (Setting) | Setting Menu |
| | Setting reprint times |
| | Pause |

❖ **Printer Status Messages**

The following table shows the printer status messages that are displayed during normal operation:

| Printer Status Message | Meaning |
|-------------------------------|---|
| READY | Ready to print. |
| PROCESSING | Busy processing data. |
| SLEEP | In Sleep status (power save mode). |
| PRINTING | Printing. |
| SELF TEST | Performing self-diagnostics. |
| PAUSE | The printer has suspended feeding forms. Pressing the Go button resumes form feed. |
| NOW INITIALIZING | The printer is setting up. |
| WARMING UP | The printer is warming up. |
| MEMORY SIZE=XX MB | This printer has XX MB memory. |
| JOB CANCELLING | Cancelling the job. |
| RESOLUTION ADAPT | Printing with reduced resolution. |
| PRESS SET TO PRINT | Press the Set button to start printing. |
| RESET TO FACTORY SETTING | The printer settings return to the factory settings. |

How to Use the Control Panel

When you operate the **Menu** buttons (**+**, **-**, **Set**, **Back**), remember the following basic steps:

- If control panel buttons are not pressed for 30 seconds, the LCD returns to READY.
- When you press the **Set** button to select a setting, ***** (an asterisk) briefly appears at the end of display. After that, the display returns to the previous menu level.
- If you make a change and then press the **Back** button before you press the **Set** button, the display will return to the previous menu with the original setting unchanged.
- When you operate the **+**, **-**, **Set**, **Back** buttons, remember the following basic steps.

◆ **For Example: When You Want to Turn the MP FIRST Setting ON**

Choose this setting to feed paper from the Multi-purpose Tray first.

READY



Press the **+** button.
Press the **+** or **-** button to scroll forward or backward through the menu selections.

INFORMATION



Press the **Set** button.
Press the **Set** button to enter the next level of the displayed menu.

PAPER



Press the **Set** button to proceed to the next menu level.

SOURCE



Press the **+** button.

MP FIRST



Press the **Set** button.

=OFF *



Press the **+** button.

=ON



Press the **Set** button.
An asterisk ***** briefly appears at the end of the display.
The default setting is indicated by an *****.

=ON *

Control Panel Menus

We named the Paper tray in this manual and LCD panel as shown below:

| | |
|---------------------|---------|
| Upper Paper Tray | Tray 1 |
| Multi-purpose Tray | MP Tray |
| Optional Lower Tray | Tray 2 |

There are 8 modes. For more information about the selections available for each mode, refer to the pages listed below.

◆ **INFORMATION**

For more information, see page 3-19

◆ **PAPER**

For more information, see page 3-20

◆ **QUALITY**

For more information, see page 3-20

◆ **SETUP**

For more information, see page 3-21

◆ **PRINT MENU**

For more information, see page 3-22

◆ **NETWORK**

For more information, see page 3-26

◆ **INTERFACE**

For more information, see page 3-27

◆ **RESET MENU**

For more information, see page 3-28

❖ INFORMATION

| Setting Menu | Description | |
|-----------------|----------------------------------|---|
| PRINT SETTINGS | Print the Configuration page. | |
| PRINT TEST | Print the Test page. | |
| RRINT DEMO | Print the Demonstration page. | |
| PRINT FILE LIST | Print the File List. | |
| PRINT FONTS | Print the Font List and samples. | |
| | Sub-Setting Menu | Description |
| VERSION | SER.NO=##### | Printer serial number. |
| | ROM VER=#### | ROM firmware version (only Network users) |
| | ROM DATE ##/##/## | ROM date (only Network users) |
| | NET VER=#### | Network firmware version |
| | NET DATE ##/##/## | Network date |
| | RAM SIZE=###MB | The size of memory in this printer. |
| MAINTENANCE | PAGE COUNTER | =##### |
| | REMAIN DRUM | =##### |
| | REMAIN PF KIT1 | =##### |
| | REMAIN PF KIT2 | =##### |
| | REMAIN FUSER | =##### |
| | REMAIN LASER | =##### |

❖ PAPER

| Setting Menu | Description |
|---------------|---|
| SOURCE | =AUTO / MP TRAY / TRAY1 / TRAY2 |
| TRAY PRIORITY | =MP>T1>T2 / T1>T2>MP |
| MP FIRST | =OFF/ON Feed paper from the MP tray first. |
| MP SIZE | =ANY / LETTER / LEGAL / A4 / ... |
| MANUAL FEED | =OFF/ON |
| TRAY1 SIZE | =ANY / LETTER / LEGAL / A4 / ... |
| TRAY2 SIZE | =ANY / LETTER / LEGAL / A4 / ... |
| DUPLEX | =OFF/ON(LONG BIND)/ON(SHORT BIND) |

❖ QUALITY

| Setting Menu | Description |
|--------------|---|
| RESOLUTION | =300/600/HQ1200 You can choose a print resolution of 300, 600 or HQ1200. |
| HRC | =OFF/LIGHT/MEDIUM/DARK HRC: High Resolution Control offers improved print quality of characters and graphics that conventional laser printers cannot attain with a resolution of 300 or 600 dpi. |
| TONER SAVE | =OFF/ON |
| DENSITY | =-6:0:6 Increase or decrease the print density. |

❖ SETUP

| Setting Menu | Description | |
|-----------------|--|--|
| LANUGAGE | = ENGLISH /FRANÇAIS /... | |
| LCD DENSITY | =0/1/2 | |
| POWER SAVE TIME | =1:99MIN. | |
| AUTO CONTINUE | =OFF/ON | |
| LOCK PANEL | =OFF/ON Turns the lock panel function on/off. | |
| | PASS NO.=### | |
| RERRINT | =ON/OFF | |
| PAGE PROTECTION | PROTECT = AUTO | AUTO, OFF, LETTER, A4 OR LEGAL |
| EMULATION | =AUTO (EPSON)/AUTO(IBM)/ HP LASERJET/.... | |
| KEEP PCL | =OFF/ON | |
| RAMDISK SIZE | =0/1/2...MB | RESTART? |
| DELETE STORAGE | Delete the internal flash memory print data. | |
| | Sub-Setting Menu | Description |
| | SECURE FILE | Select the User Name, Job Name and Password. |
| | DATA ID | =#### |
| | MACRO ID | =#### |
| | FONT ID | =#### |
| | FORMAT | OK? |

❖ PRINT MENU

| Setting Menu | Description | |
|-----------------------|--|---|
| MEDIA TYPE | =PLAIN PAPER / TRANSPARENCIES / THIN PAPER / ... | |
| PAPER | Set cut sheet paper size to LETTER, LEGAL, A4, ... | |
| COPIES | =1:999 Shows the number of printed pages. | |
| ORIENTATION | =PORTRAIT/LANDSCAPE This printer can print pages in portrait or landscape orientation. | |
| PRINT POSITION | This printer can be adjusted to correct the page format. | |
| | Sub-Setting Menu | Description |
| | X OFFSET=0 | Move the print start position (at the upper left corner of pages) horizontally up to -500 (left) to +500 (right) dots in 300 dpi units. |
| Y OFFSET=0 | Move the print start position (at the upper left corner of pages) vertically up to -500 (up) to +500 (down) dots in 300 dpi units. | |
| AUTO FF=OFF | =OFF/1:5:99 (sec) Allows you to print the remaining data without pressing the Go button. | |
| FF SUPPRESS | =OFF/ON Turn the form feed suppress function on/off. | |

❖ **PRINT MENU (continued)**

| Setting Menu | Description | |
|--------------------|---|--|
| HP LASERJET | Sub-Setting Menu | Description |
| | FONT NO. | =l0000:????? |
| | FONT PITCH/POINT | =????.?? |
| | SYMBOL/CHARACTER SET | PC-8/... Set the symbol set or the character set. |
| | TABLE PRINT | Print code table. |
| | AUTO LF=OFF | =OFF/ON ON: CR→CR+LF, OFF: CR→CR |
| | AUTO CR=OFF | =OFF/ON ON: LF→LF+CR, FF+CR, or VT→VT+CR OFF: LF→LF, FF→FF, or VT→VT |
| | AUTO WRAP=OFF | =OFF/ON Line feed and carriage return occurs when the printer reaches the right margin. |
| | AUTO SKIP=ON | =ON/OFF Line feed and carriage return occurs when the printer position reaches the bottom margin. |
| | LEFT MARGIN | =#### Set the left margin at column 0 to 126 columns at 10 cpi. |
| | RIGHT MARGIN | =#### Set the right margin at column 10 to 136 columns at 10 cpi. |
| TOP MARGIN | =#### Set the top margin at a distance from the top edge of the paper: 0, 0.33, 0.5, 1.0, 1.5 or 2.0" Factory setting=0.5 | |

❖ **PRINT MENU (continued)**

| Setting Menu | Description | |
|------------------------------------|--|---|
| HP LASERJET (continued) | BOTTOM MARGIN | =#### Set the bottom margin at a distance from the bottom edge of the paper: 0, 0.33, 0.5, 1.0, 1.5 or 2.0” Factory setting: 0.33(None-HP), 0.5(HP) |
| | LINES | =#### Set the number of lines per page from 5 to 128 lines. |
| EPSON FX-850 | FONT NO. | =l0000:????? |
| | FONT PITCH/POINT | =????.?? |
| | SYMBOL/CHARACTER SET | PC-8/... Set the symbol set or the character set. |
| | TABLE PRINT | Print code table. |
| | AUTO LF=OFF | =OFF/ON ON: CR→CR+LF OFF: CR→CR |
| | AUTO MASK | =OFF/ON |
| | LEFT MARGIN | =#### Set the left margin at column 0 to 126 columns at 10 cpi. |
| | RIGHT MARGIN | =#### Set the right margin at column 10 to 136 columns at 10 cpi. |
| | TOP MARGIN | =#### Set the top margin a distance from the top edge of the paper: 0, 0.33, 0.5, 1.0, 1.5 or 2.0” Factory setting=0.33 |
| | BOTTOM MARGIN | =#### Set the bottom margin a distance from the top edge of the paper: 0, 0.33, 0.5, 1.0, 1.5 or 2.0” Factory setting=0.33 |
| LINES | =#### Set the number of lines per page from 5 to 128 lines. | |

❖ **PRINT MENU (continued)**

| Setting Menu | Description | |
|----------------|----------------------|--|
| IBM PROPRINTER | FONT NO. | =I0000:????? |
| | FONT PITCH/POINT | =????.?? |
| | SYMBOL/CHARACTER SET | PC-8/... Set the symbol set and the character set. |
| | TABLE PRINT | Print code table. |
| | AUTO LF=OFF | =OFF/ON ON: CR→CR+LF, OFF: CR→CR |
| | AUTO CR=OFF | =OFF/ON |
| | LEFT MARGIN | =#### Set the left margin at column 0 to 126 columns at 10 cpi. |
| | RIGHT MARGIN | =#### Set the right margin at column 10 to 136 columns at 10 cpi. |
| | TOP MARGIN | =#### Set the top margin a distance from the top edge of the paper: 0, 0.33, 0.5, 1.0, 1.5 or 2.0" Factory setting=0.33 |
| | BOTTOM MARGIN | =#### Set the bottom margin a distance from the top edge of the paper: 0, 0.33, 0.5, 1.0, 1.5 or 2.0" Factory setting=0.33 |
| BR-SCRIPT | LINES | =#### Set the number of lines per page from 5 to 128 lines. |
| | ERROR PRINT | =OFF/ON |
| | APT | =OFF/ON APT: Advanced Photoscale Technology offers photographic fine grayscale on graphics. APT setting is available only at 600 dpi. |

❖ NETWORK

| Setting Menu | Description | |
|--------------|-------------------------------------|------------------------------|
| TCP/IP | Sub-Setting Menu | Description |
| | TCP/IP ENABLE | =ON/OFF |
| | IP ADDRESS= | ###.###.###.### |
| | SUBNET MASK= | ###.###.###.### |
| | GATEWAY= | ###.###.###.### |
| | IP BOOT TRIES | =# |
| | IP METHOD | =AUTO/STATIC/RARP/BOOTP/DHCP |
| NETWARE | NETWARE ENABLE | =ON/OFF |
| | NET FRAME | =AUTO/8023/ENET/8022/SNAP |
| APPLETALK | =ON/OFF | |
| NETBEUI | =ON/OFF | |
| DLC/LLC | =ON/OFF | |
| BANYAN | =ON/OFF | |
| LAT | =ON/OFF | |
| NETBIOS/IP | =ON/OFF | |
| ENET | =AUTO/100B-FD/100B-HD/10B-FD/10B-HD | |

❖ INTERFACE

| Setting Menu | Description | |
|----------------------|---|---|
| AUTO IF TIME | = 1:5:99 (sec) You must set the timeout period for the auto interface selection. | |
| INPUT BUFFER | = Level1:5:15 Increase or decrease the input buffer capacity. | RESTART PRINTER? |
| PARALLEL | When using the parallel interface | |
| | Sub-setting Menu | Description |
| | HIGH SPEED | =ON/OFF Turns the high-speed parallel communications ON/OFF. |
| BI-DIR=ON/OFF | =ON/OFF Turns the bi-directional parallel communications ON/OFF. | |

❖ **RESET MENU**

| Setting Menu | Description |
|----------------------|--|
| RESET PRINTER | Resets the printer and restores all printer settings – including command settings – to settings you have previously made with the control panel buttons. |
| FACTORY RESET | Resets the printer and restores all printer settings – including command settings – to the factory settings. See “List of Factory Settings.” |

❖ Set IP Address

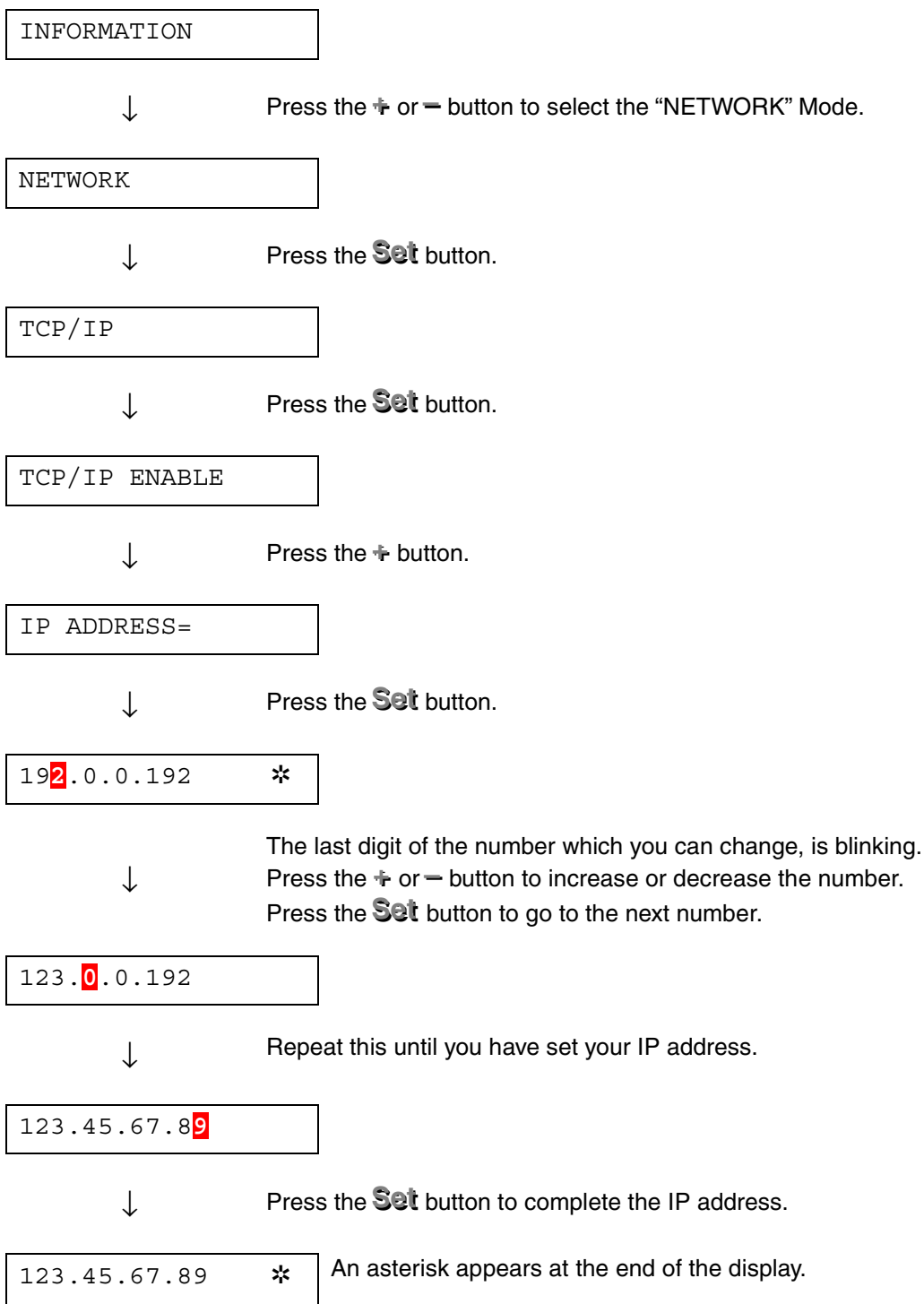

❖ **About Emulation Modes**

This printer has the following emulation modes.

◆ **HP LaserJet Mode**

The HP LaserJet mode (or HP mode) is the emulation mode in which this printer emulates the Hewlett-Packard LaserJet laser printer. Many software applications support this type of laser printer. Using this mode will allow your printer to operate at its optimum performance with those applications.

◆ **BR-Script 3 Mode**

BR-Script is an original page description language and a PostScript language emulation interpreter. This printer supports level 3. The BR-Script interpreter of this printer enables full and satisfactory control of text and graphics on pages.

Average users will not need extensive knowledge of the PostScript language. However, if you want to obtain technical information about PostScript commands, see the following commercial manuals:

- Adobe Systems Incorporated. PostScript Language Reference Manual, 2nd Edition. Menlo Park: Addison-Wesley Publishing Company, Inc., 1990.
- Adobe Systems Incorporated. PostScript Language Program Design. Menlo Park: Addison-Wesley Publishing Company, Inc., 1988.
- Adobe Systems Incorporated. PostScript Language Reference Manual. Menlo Park: Addison-Wesley Publishing Company, Inc., 1985.
- Adobe Systems Incorporated. PostScript Language Tutorial and Cookbook. Menlo Park: Addison-Wesley Publishing Company, Inc., 1985.
- Adobe Systems Incorporated. PostScript Language Reference Manual, third Edition. Addison-Wesley Longman, Inc., 1999.

◆ **EPSON FX-850 and IBM Proprinter XL Mode**

The EPSON FX-850 and IBM Proprinter XL modes are the emulation modes that this printer emulates to meet the industry-standard for dot matrix printers of their respective manufacturers. Some applications support these dot matrix printer emulations. Use these emulation modes for optimum performance when printing from those types of applications.

❖ List of Factory Settings

The following table shows the initial factory default settings.

❖ Note

-
- The settings are subject to the emulation mode. Effective modes are indicated in parentheses in the following table.
 - The following settings cannot be restored to the factory settings with the RESET menu in the “FACTORY SETTINGS” mode: INTERFACE MODE, HRC SETTING, PAGE PROTECTION, SCALABLE FONT, LOCK PANEL, PAGE COUNTER and local language for display messages.
 - The COPY setting is always restored to the factory setting when the printer is turned off and on again.
 - It is not possible to reset the NETWORK settings from the Control panel. If you wish to reset the print server back to its default factory settings (resetting all information such as the password and IP address information) hold down the Network Test Button of the Network board (NC-4100h) for more than 5 seconds.
-

| MODE | MENU | Factory Setting |
|-------------|-----------------|------------------------|
| | SOURCE | =AUTO |
| | TRAY PRIORITY | =MP>T1>T2 |
| | MP FIRST | =OFF |
| | MP SIZE | =ANY |
| | MANUAL FEED | =OFF |
| | TRAY1 SIZE | =ANY |
| | TRAY2 SIZE | =ANY |
| | DUPLEX | =OFF |
| QUALITY | RESOLUTION | =600 |
| | HRC | =MEDIUM |
| | TONER SAVE | =OFF |
| | DENSITY | =0 |
| SETUP | LANGUAGE | =ENGLISH |
| | LCD DENSITY | =0 |
| | POWER SAVE TIME | =5 MIN. |
| | AUTO CONTINUE | =OFF |
| | LOCK PANEL | =OFF |
| | REPRINT | =ON |
| | EMULATION | =AUTO (EPSON) |
| | KEEP PCL | =OFF |

| MODE | MENU | Factory Setting | |
|--------------------|----------------|------------------------------|--|
| PRINT MENU | MEDIA TYPE | =PLAIN PAPER | |
| | PAPER | =A4/LETTER | |
| | COPIES | =1 | |
| | ORIENTATION | =PORTRAIT | |
| | PRINT POSITION | X OFFSET=0 Y OFFSET=0 | |
| | AUTO FF TIME | =5 | |
| | FF SUPPRESS | =OFF | |
| | HP LASER JET | FONT NO.=IO59 | |
| | | FONT PITCH/POINT=10.00/12.00 | |
| | | SYMBOL/CHARACTER SET=PC8 | |
| | | AUTO LF=OFF | |
| | | AUTO CR=OFF | |
| | | AUTO WRAP=OFF | |
| | | AUTO SKI=ON | |
| | | LEFT MARGIN=#### | |
| | | RIGHT MARGIN=#### | |
| | | TOP MARGIN=#### | |
| BOTTOM MARGIN=#### | | | |
| LINES=#### | | | |

| MODE | MENU | Factory Setting |
|---------------------------|----------------|-------------------------------|
| PRINT MENU (continued) | EPSON FX-850 | FONT NO.= IO 59 |
| | | FONT PITCH/POINT=10.00/12.00 |
| | | SYMBOL/CHARACTER SET=US ASCII |
| | | AUTO LF=OFF |
| | | AUTO MASK=OFF |
| | | LEFT MARGIN=#### |
| | | RIGHT MARGIN=#### |
| | | TOP MARGIN=#### |
| | | BOTTOM MARGIN=#### |
| | | LINES=#### |
| | IBM PROPRINTER | FONT NO.= IO 59 |
| | | FONT PITCH/POINT=10.00/12.00 |
| | | SYMBOL/CHARACTER SET=PC8 |
| | | AUTO LF=OFF |
| | | AUTO CR=OFF |
| | | LEFT MARGIN=#### |
| | | RIGHT MARGIN=#### |
| | | TOP MARGIN=#### |
| | | BOTTOM MARGIN=#### |
| | | LINES=#### |
| | BR-SCRIPT | ERROR PRINT=OFF |
| | | APT=OFF |

| MODE | MENU | Factory Setting |
|---------|------------|------------------------|
| NETWORK | TCP/IP | TCP/IP ENABLE=ON |
| | | IP METHOD=AUTO |
| | | IP ADDRESS=192.0.0.192 |
| | | SUBNET MASK=0.0.0.0 |
| | | GATEWAY=0.0.0.0 |
| | | IP BOOT TRIES=3 |
| | | IP METHOD=AUTO |
| | NETWARE | NETWARE ENABLE=ON |
| | | NET FRAME=AUTO |
| | APPLETALK | =ON |
| | NETBEUI | =ON |
| | DLC/LLC | =ON |
| | BANYAN | =ON |
| | LAT | =ON |
| | NETBIOS/IP | =ON |
| ENET | =AUTO | |

CHAPTER 4

OPTIONS

Optional Accessories

This printer has the following optional accessories. You can increase the capabilities of the printer with these items.

◆ Options

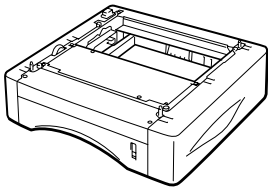
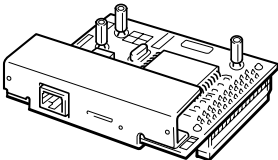
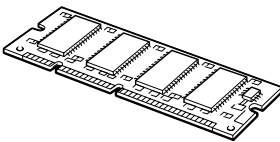
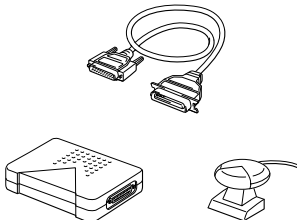
| Lower Tray Unit | Network Board | Additional Memory | IrDA Interface |
|--|--|--|--|
| LT-500 | NC-4100h | 100pin DIMM | IR-1000 |
|  |  |  |  |
| See Lower tray unit in this chapter | See Network option in this chapter | See RAM expansion in this chapter | See IrDA interface in this chapter |

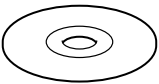
| Optional Font Package |
|---|
| BS-3000 |
|  |
| See Optional font package in this chapter |

Lower Tray Unit (LT-500)

The Lower Tray Unit (tray 2) is a device that functions as an additional paper source. It can hold a maximum of 250 sheets of paper (80 g/m² or 21 lb.).

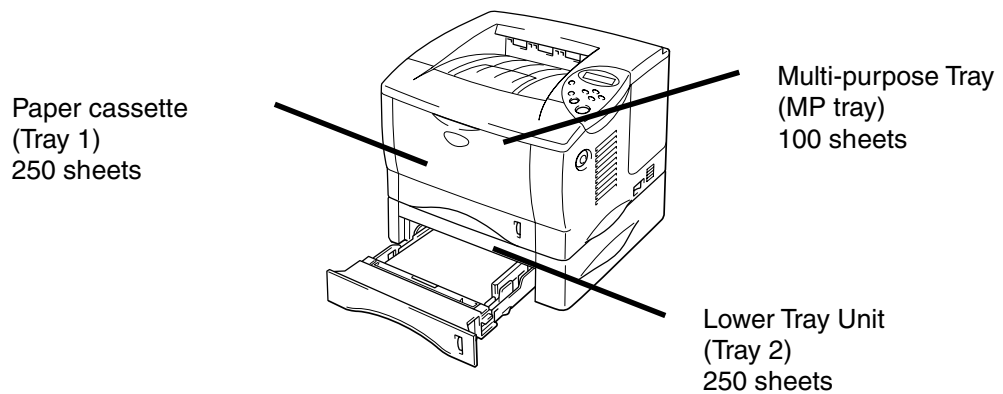

Expands up to a total of 600 sheets

Fig. 4-1

To purchase the optional Lower Tray Unit (Tray 2), consult the dealer where you purchased the printer.

Installing the Lower Tray Unit

Install the optional Lower Tray Unit under the printer as follows:

- ☛ **1.** Turn off the power switch, and then unplug the power cord.
- ☛ **2.** Close the Front Cover, Multi-purpose Tray, Face Up Output Tray and Extension Flap.
- ☛ **3.** Lift the printer carefully with both hands and put it on top of the Lower Tray Unit. Make sure that the alignment pins of the Lower Tray Unit are positioned into the guide holes of the underside of the printer.

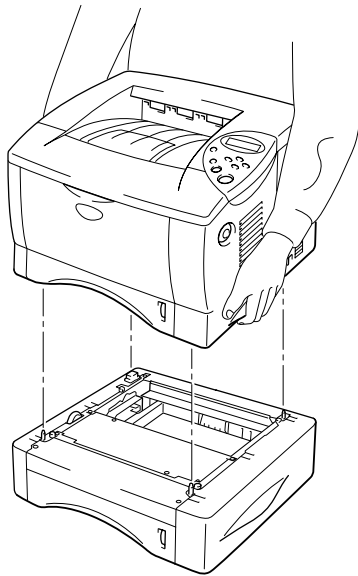
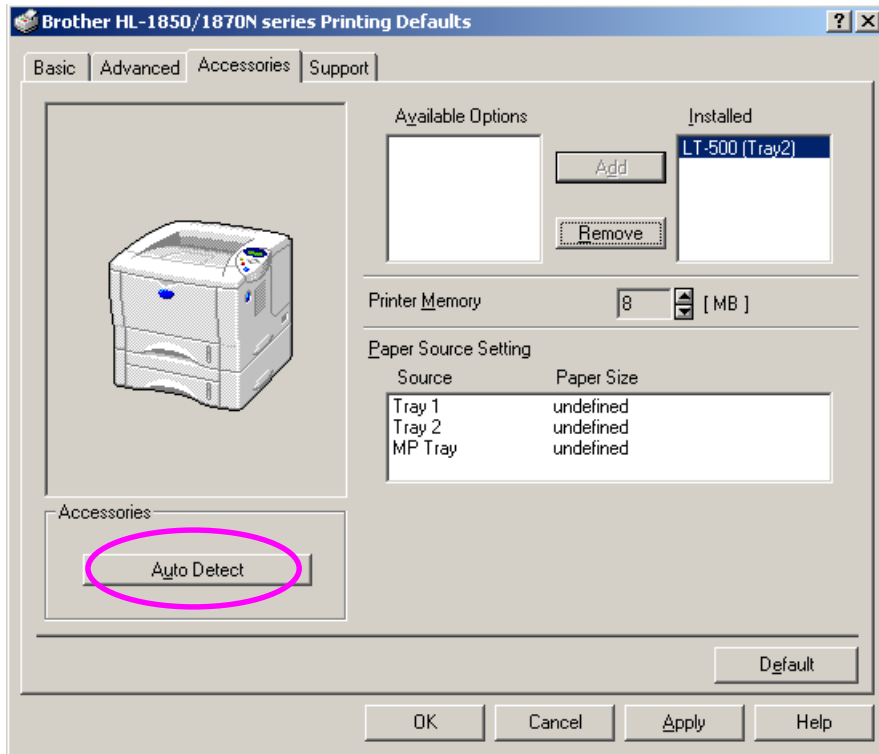

Fig. 4-2

- ☛ **4.** To install the Lower Tray Unit, refer to the instructions supplied with the Lower Tray Unit.

5. After installing the Lower Tray Unit, press Auto Detect in the Accessories tab of the printer driver.



6. Change the Paper size, Media Type and Paper resource setting in the printer driver Properties tab.

Network Option NC-4100h (For HL-1850 User Only)

Installing the Network board enables you to use the printer in the TCP/IP, IPX/SPX, AppleTalk, DLC/LLC, Banyan VINES, DEC LAT and NetBEUI environments. Useful utilities such as BRAdmin Professional and Network Printing software for the administrator are included. For more information about Set Up, see the Network User's Guide.

Installing the Network Board

1. Turn off the printer, and then unplug the power cord. Disconnect the interface cable (printer cable) from the printer.
2. Remove the Interface Cover by sliding it.

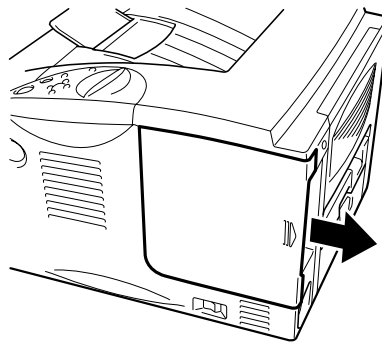

Fig. 4-3

3. Unscrew the two screws that secure the PCB Access Plate. Remove the plate.

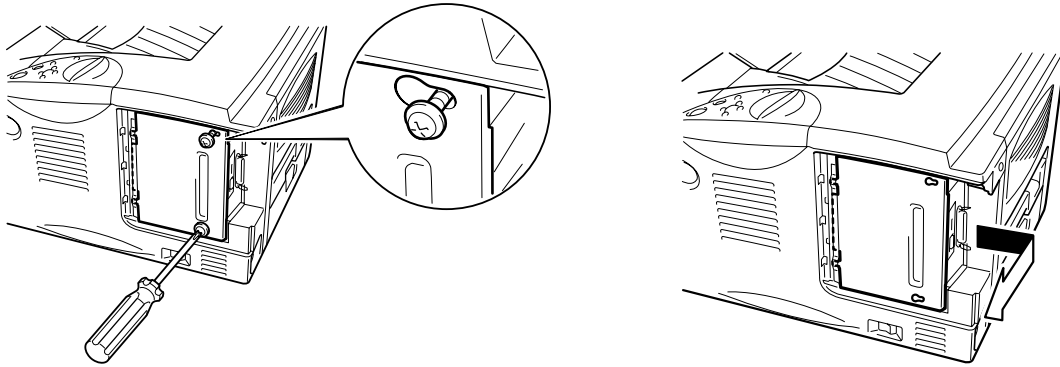

Fig. 4-4

4. Remove the two screws securing the Network Board Cover Plate and remove the plate.

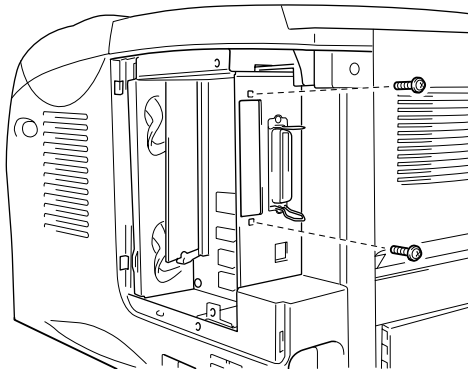

Fig. 4-5

5. Unpack the Network Board.

6. Insert the Network Board connector into the PCB connector, and then secure it with the two screws removed in Step 4.

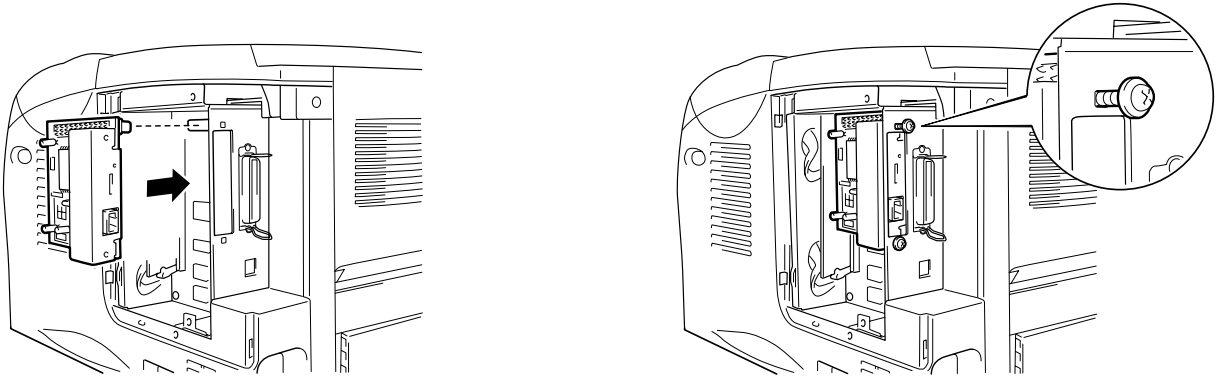

Fig. 4-6

7. Re-install the PCB Access Plate, and then secure it with the two screws you removed in Step 3.

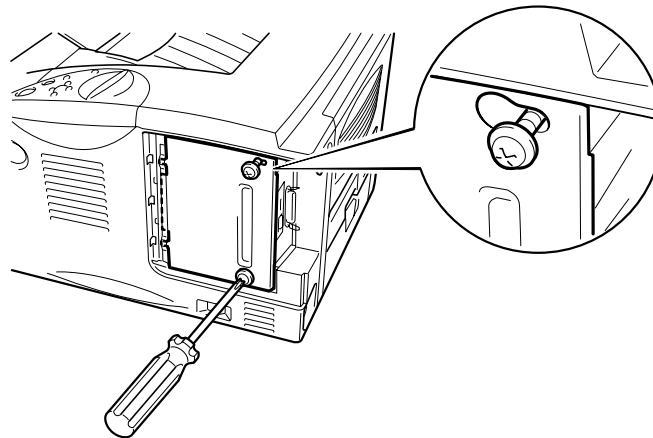

Fig. 4-7

8. Re-install the Interface Cover.

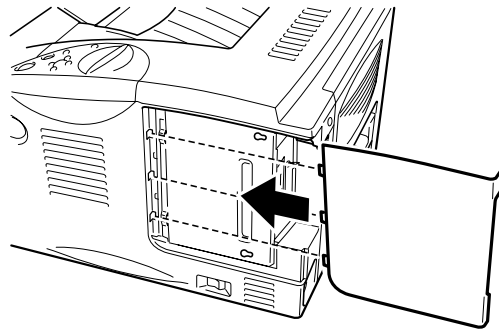

Fig. 4-8

9. Plug the power cord into the AC outlet, and then turn on the power switch.

RAM Expansion

HL-1850:

This printer has 16 Mbytes of standard memory and one slot for optional expansion memory. The memory can be expanded up to 144 Mbytes by installing a commercially available dual in-line memory modules (DIMMs). (The standard memory installed varies depending on the country where the printer is purchased.)

HL-1870N:

This printer has 32 Mbytes of standard memory and one slot for optional expansion memory. The memory can be expanded up to 144 Mbytes by installing a commercially available dual in-line memory modules (DIMMs). (The standard memory installed varies depending on the country where the printer is purchased.)

This printer uses memory modules that are: 100 pins, no-parity, SDRAM with 8 Mbytes or more. This printer is not compatible with Extended Data Output (EDO) DIMM, or DIMM that uses 2 Mbytes SDRAM.

◆ **Minimum Memory Recommendation**

HL-1850 (Including 16 Mbytes of Internal Memory)

HP LaserJet, EPSON FX-850, and IBM Proprinter XL emulation modes

| | 300 dpi | 600 dpi | HQ1200 |
|-----------|----------|----------|----------|
| Letter/A4 | Standard | Standard | Standard |
| Legal | Standard | Standard | Standard |

BR-Script 3 mode

| | 300 dpi | 600 dpi | HQ1200 |
|-----------|----------|----------|----------|
| Letter/A4 | Standard | Standard | Standard |
| Legal | Standard | Standard | Standard |

Duplex printing

| | 300 dpi | 600 dpi | HQ1200 |
|-------------|----------|----------|-----------|
| HP LaserJet | Standard | Standard | 32 Mbytes |
| BR-Script 3 | Standard | Standard | 32 Mbytes |

HL-1870N (Including 32 Mbytes of Internal Memory)

HP LaserJet, EPSON FX-850, and IBM Proprinter XL emulation modes

| | 300 dpi | 600 dpi | HQ1200 |
|-----------|----------|----------|----------|
| Letter/A4 | Standard | Standard | Standard |
| Legal | Standard | Standard | Standard |

BR-Script 3 mode

| | 300 dpi | 600 dpi | HQ1200 |
|-----------|----------|----------|----------|
| Letter/A4 | Standard | Standard | Standard |
| Legal | Standard | Standard | Standard |

Duplex printing

| | 300 dpi | 600 dpi | HQ1200 |
|-------------|----------|----------|----------|
| HP LaserJet | Standard | Standard | Standard |
| BR-Script 3 | Standard | Standard | Standard |

The following DIMM size can be installed:

- 16 Mbyte TECHWORKS PM-HP 16M-BR
- 32 Mbyte TECHWORKS PM-HP 32M-BR
- 64 Mbyte TECHWORKS PM-HP 64M-BR
- 128 Mbyte TECHWORKS PM-HP 128M-BR

In general, DIMM must have the following specifications:

Type: 100 pin and 32 bit output
CAS Lantency 2 or 3
Clock Frequency 66MHz or more
Capacity: 16, 32, 64 Mbyte or 128 Mbyte
Height: 46mm (1.8 inches) or less
Parity NONE
Dram Type: SDRAM 4 Bank
SDRAM can be used.

•• **Note**

For more information, consult the dealer where you purchased the printer.

Installing Additional Memory

Install additional memory (DIMM) as follows:

1. Turn off the printer, and then unplug the power cord from the AC outlet. Disconnect the interface cable (printer cable) from the printer.

Note

Be sure to turn off the power to the printer before you install or remove the DIMM.

2. Remove the Interface cover by sliding it.

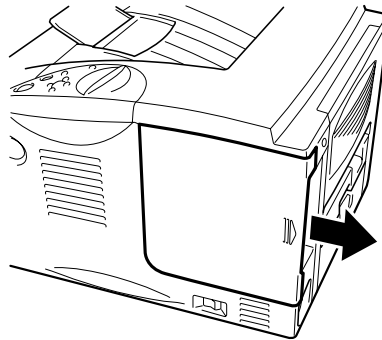

Fig. 4-9

3. Unscrew the two screws that secure the PCB Access Plate. Slide the plate toward you and remove it.

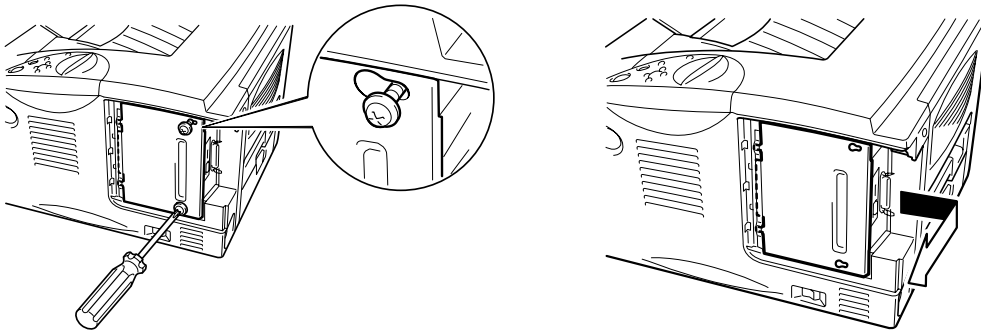

Fig. 4-10

4. Unpack the DIMM and hold it by the edges.

! *Caution*

DIMM boards can be damaged by even a small amount of static electricity. Do not touch the memory chips or the board surface. Wear an antistatic wrist strap when you install or remove the board. If you do not have an antistatic wrist strap, frequently touch the bare metal on the printer.

5. As you hold the DIMM by the edges, align the notches on the DIMM with the DIMM slot.

- 6. Press the DIMM straight into the slot (press firmly). Make sure the locks on each side of the DIMM snap inward into place. (To remove a DIMM, the locks must be released.)

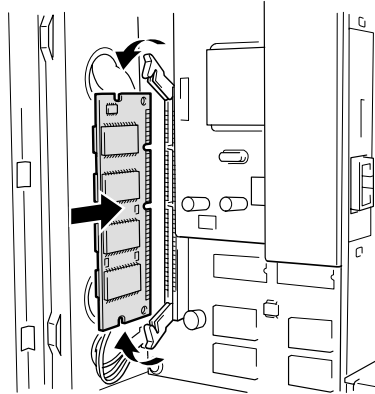

Fig. 4-11

- 7. Install the PCB Access Plate. Secure the PCB Access Plate with the two screws.

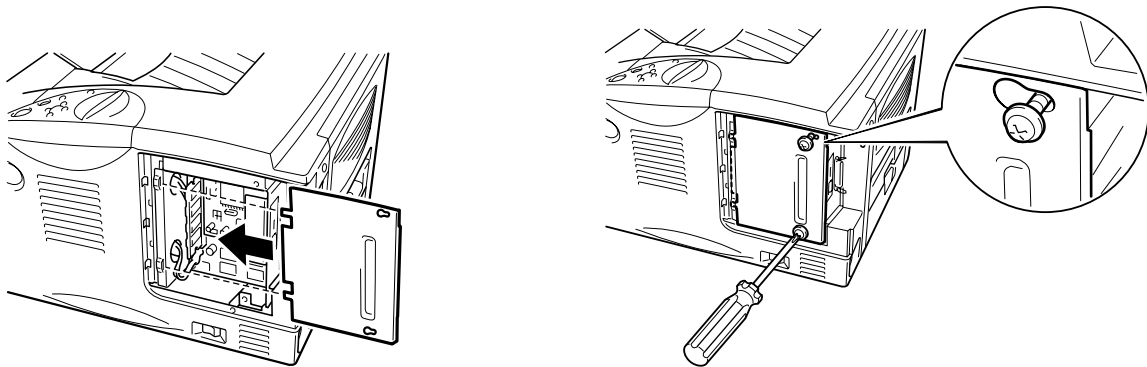

Fig. 4-12

- 8. Re-install the Interface Cover.
- 9. Reconnect the interface cable (printer cable) from your computer. Plug the power cord into the AC outlet, and then turn on the power switch.
- 10. After you turn on the printer, the current RAM disk size will appear on the LCD. Check it to make sure you added the new memory correctly.

IrDA Interface (IR-1000)

IR-1000 connects to any printer and print data without connecting cables.

- Support IrDA1.1 Infrared communication standard.
- Fully compatible with Windows® 95/98/Windows® Me, Windows NT® 4.0, Windows® 2000/XP Infrared printer device.
- Transmits and receives data up to 4 Mbits/s.
- Connects to the PC parallel port and connects to the Centronic (parallel) port on the printer.
- Allows a printer to communicate with an infrared-equipped portable computer.
- Transmission range: 1 cm (0.39 inch) up to 100 cm (39 inch) meet IrDA standard.
- 30 degrees cone angle.
- Selects between infrared or parallel port.

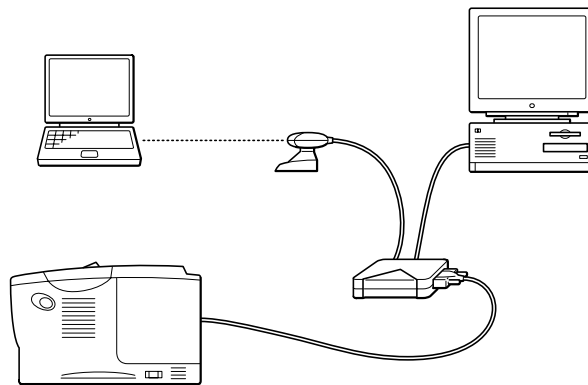

Fig. 4-13

Optional Font Package (BS-3000)

The optional font package (BS-3000) is a CD-ROM from which you can install the 136 PS3 Agfa TrueType Fonts.

CHAPTER 5

ROUTINE MAINTENANCE

Replacing the Consumables

You need to replace the consumables regularly. When the time comes to replace consumables, the following messages will appear on the LCD panel.

(Appears at intervals)

TONER LOW

See the 'TONER LOW' message explanation in this chapter.

TONER EMPTY

See the 'TONER EMPTY' message explanation in this chapter.

CHANGE DRUM SOON

See the 'CHANGE DRUM SOON' message explanation in this chapter.

◆ **Accessories**

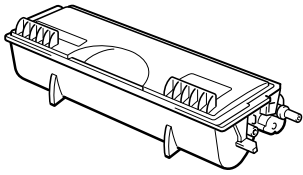
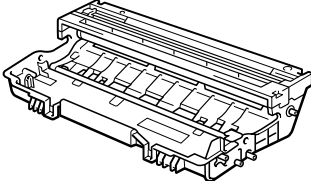
| Toner Cartridge | Drum Unit |
|---|--|
|  |  |
| See 'Replacing the Toner Cartridge' in this chapter | See 'Replacing the Drum Unit' in this chapter |

❖ **Replacing Maintenance Parts**

You need to replace the maintenance parts regularly to maintain print quality. When it is time to replace the parts, the following messages will appear on the LCD.

REPLACE FUSER

See "Maintenance Messages" in this chapter.

REPLACE PF KIT

See "Maintenance Messages" in this chapter.

REPLACE LASER

See "Maintenance Messages" in this chapter.

❖ **Toner Cartridge**

A new toner cartridge contains enough toner to print up to 6,500 A4/Letter-size single-sided pages at 5% coverage (if the print density is set at level 0).

•• **Note**

- The amount of toner used varies according to what is printed on the page and the print density setting.
 - The more that is printed, the more toner will be used.
 - If you change the print density setting for lighter or darker printing, the amount of toner that is used will change (more for darker printing).
 - Do not unpack the toner cartridge until immediately before you are to use it in the printer.
-

❖ **TONER LOW Message**

(appears at intervals)

| |
|-----------|
| TONER LOW |
|-----------|

If the LCD shows this message, the toner cartridge has nearly run out of toner. Purchase a new toner cartridge and have it ready before you get a TONER EMPTY message. To replace the toner cartridge, refer to ["Replacing the Toner Cartridge"](#) in this chapter.

❖ **TONER EMPTY Message**

Check printed pages, page counter, and display messages routinely. If the display shows the following message, the printer has run out of toner or the toner is not evenly distributed inside the cartridge.

TONER EMPTY

❖ **Replacing the Toner Cartridge**

•• **Note**

To make sure you get the best print quality, make sure you use quality toner cartridges. If you want to buy toner cartridges, contact the dealer who you bought the printer from.

- 1 Press the Cover Release Button and then open the Front Cover.

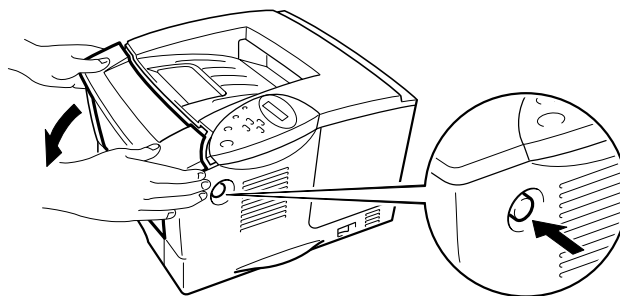

Fig. 5-1

2. Pull out the Drum Unit Assembly.

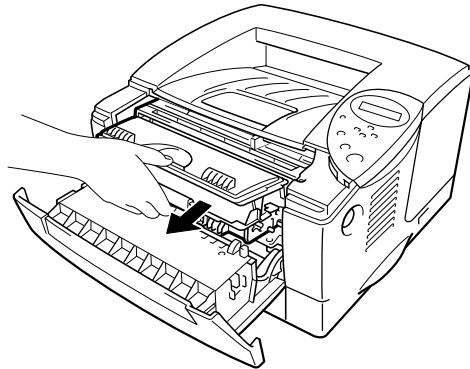
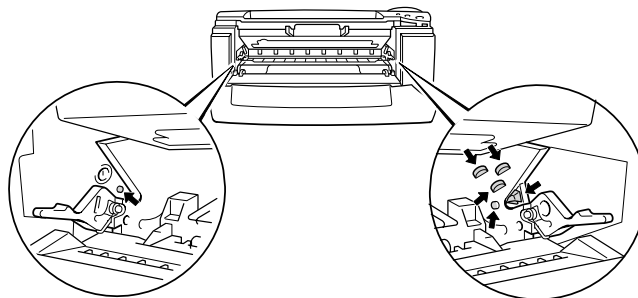

Fig. 5-2

! **Caution**

- We recommend that you put the Drum Unit Assembly on a piece of disposable paper or cloth in case you accidentally spill the toner.
- To prevent damage to the printer from static electricity, do not touch the electrodes shown below.



3. Press the Lock Lever down, and then pull the Toner Cartridge out of the Drum Unit Assembly.

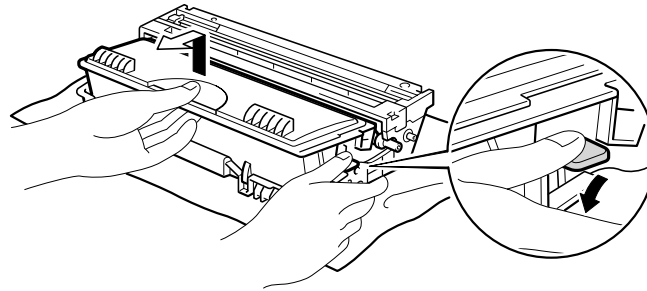

Fig. 5-3

Caution

Handle the toner cartridge carefully. If toner spills on your hands or clothes, wipe or wash it off immediately with water.

Note

-
- Make sure you seal the toner cartridge tightly so that toner powder does not spill out of the cartridge.
 - Dispose of the used toner cartridge in accordance with local plastic waste regulations.
-

4. Unpack the new Toner Cartridge. Keeping the cartridge horizontal, gently rock it from side to side five or six times.

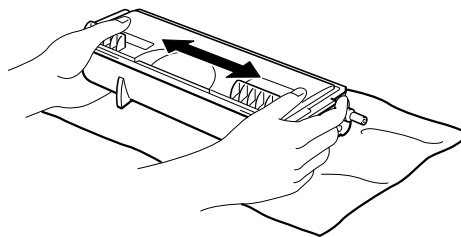

Fig. 5-4

! **Caution**

- Wait to unpack the Toner Cartridge until immediately before you put it in the printer. If Toner Cartridges are left unpacked for a long time, the toner will not last as long as it should.
 - If an unpacked Drum Unit is put in direct sunlight or room light, the unit may be damaged.
 - Use a genuine Brother Toner Cartridge that is specially formulated for high-quality printing.
 - Printing with a toner or a toner cartridge that is not made by Brother may reduce the print quality and the quality and life of the printer itself. It may also cause serious damage to the performance and life of a drum unit. The warranty does not cover problems caused by using other toners, toner cartridges or drum units.
-

- 5** Remove the protective cover.

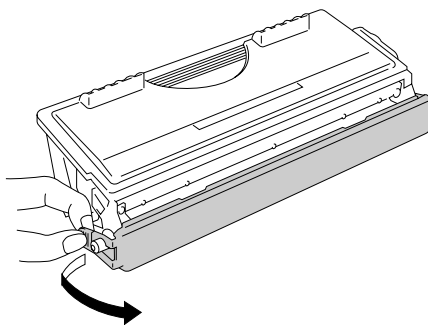

Fig. 5-5

! **Caution**

Put in the Toner Cartridge immediately after you remove the protective cover. Do not touch the shaded parts shown below as this may affect print quality.



6. Put the new Toner Cartridge into the Drum Unit until you hear it lock into place. When the Toner Cartridge is fitted correctly, the lock lever is lifted automatically.

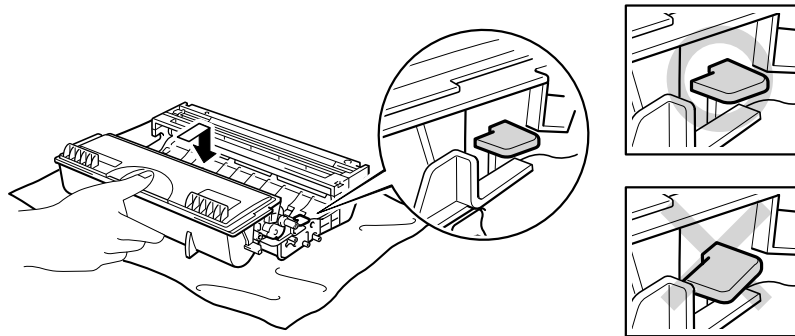

Fig. 5-6

Caution

Make sure you fit the Toner Cartridge correctly or it may separate from the Drum Unit when you pick up the Drum Unit Assembly.

7. Clean the Primary Corona Wire inside the Drum Unit by gently sliding the blue tab from right to left several times. Return the tab to the Home position (▲) before you put the Drum Unit back in the printer.

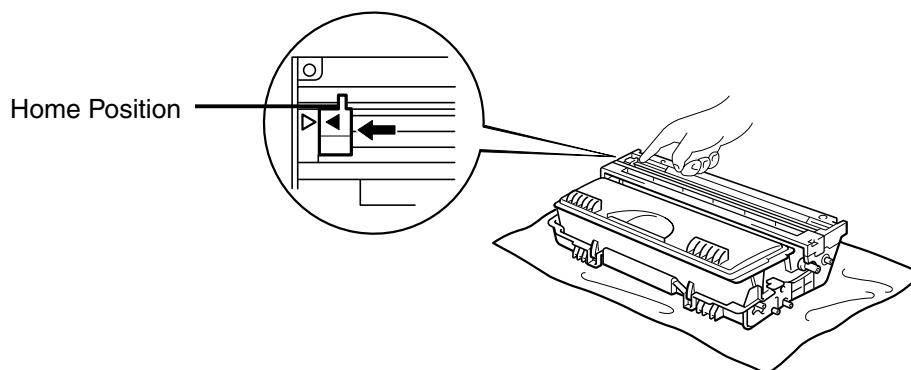

Fig. 5-7

Caution

Make sure that you return the tab to the Home position (▲) before you put the Drum Unit back in the printer. If you do not, printed pages may have vertical stripes.

8. Put the Drum Unit back into the printer. Close the Front Cover.

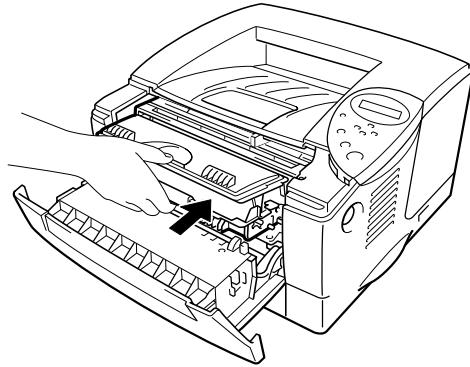

Fig. 5-8

• Note

We recommend that you clean the printer when you replace the Toner Cartridge. See “Cleaning” in this chapter.

❖ **CHANGE DRUM SOON Message**

CHANGE DRUM SOON

The printer uses a Drum Unit to create the print images on paper. If the display shows the above message, it means the Drum Unit is near the end of its life. We recommend that you replace the Drum Unit with a new one before there is a noticeable deterioration in the print quality.

❖ **Replacing the Drum Unit**

This printer can print upto 20,000 pages ^{*1} with one Drum Unit.

^{*1} At 5% coverage print (A4-Letter size). The actual number of printed pages may vary depending on the average type of print job and paper.

•• **Note**

There are many things that affect how long the drum unit lasts for, such as the temperature, humidity, type of paper, type of toner used, the number of pages in each print job and so on. Under ideal conditions, a drum unit will last for upto 20,000 pages. The actual number of pages that your drum will print may be significantly less than this estimate. Because we have no control over the many things that affect the actual drum life, we cannot guarantee a minimum number of pages that your drum will print. For best performance, only use genuine Brother toner. You should only use the printer in a clean, dust-free environment with suitable ventilation.

☞ 1. Press the Cover Release Button, and then open the Front Cover.

☞ 2. Pull out the Drum Unit Assembly.

⚠ **Caution**

- We recommend that you put the drum unit Assembly on a piece of disposable paper or cloth in case you accidentally spill the toner.
- To prevent damage to the printer from static electricity, do not touch the electrodes shown below.

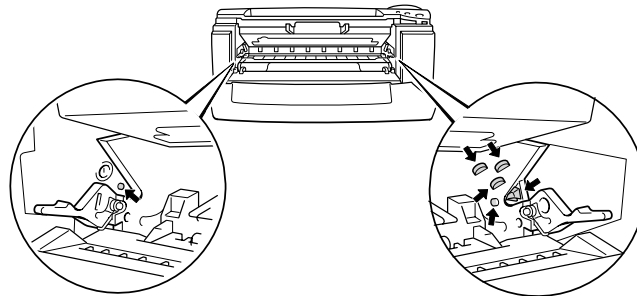

☞ 3. While pressing the Lock Lever, pull the Toner Cartridge out of the Drum Unit Assembly.

⚠ **Caution**

Handle the toner cartridge carefully. If toner spills on your hands or clothes, wipe or wash it off immediately with water.

↔ **Note**

Get rid of the used Drum Unit according to local regulations. Make sure that you seal up the Drum Unit tightly so that toner powder does not spill out of the unit.

Handle the Toner Cartridge carefully. If toner spills on your hands or clothes, wipe or wash it off immediately with water.

- ☞ 4. Unpack the new Drum Unit.

⚠ **Caution**

Wait to unpack a Drum Unit until immediately before you put it in the printer. If an unpacked Drum Unit is put in direct sunlight or room light, the unit may be damaged.

- ☞ 5. Put the Toner Cartridge into the new Drum Unit until you hear it lock into place with a click. When the Toner Cartridge is fitted correctly, the Lock Lever is will automatically lift up.

⚠ **Caution**

Make sure you fit the toner cartridge correctly, or it may separate from the Drum Unit when you pick up the Drum Unit Assembly.

- ☞ 6. Put the drum unit back in the printer.

- ☞ 7. Reset the drum counter (see the instructions supplied with the new drum unit).

⇒ **Note**

Do not reset the drum counter if you are only replacing the toner cartridge.

- ☞ 8. Close the Front Cover.

⇒ **Note**

We recommend that you clean the printer when you replace the Drum Unit. See “How to Clean the Printer” in this chapter.

Cleaning

Clean the printer exterior and interior routinely. If printouts are stained with toner, clean the printer interior and Drum Unit.

❖ **Cleaning the Printer Exterior**

1. Turn off the printer, and then unplug the power cord.



Warning

There are high voltage electrodes inside the printer. Before cleaning the printer, make sure you have turned off the power switch and unplugged the power cord from the power outlet.

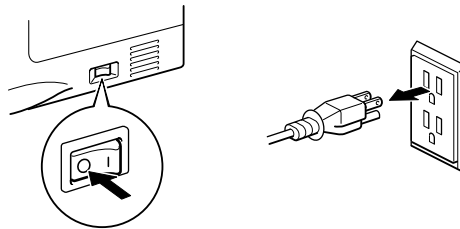

2. Wipe dirt and dust away from the printer exterior with a damp cloth and allow the printer to dry completely before turning the power on again.

Note

Use water or neutral detergents for cleaning. Cleaning with volatile liquids such as thinner or benzene will damage the surface of the printer. Do not use cleaning materials that contain ammonia. They will damage the printer and the Toner Cartridge.

3. Plug in the power cord, and then turn on the power switch.

❖ *Cleaning the Printer Interior*

1. Turn off the power switch, and then unplug the power cord.



Warning

There are high voltage electrodes inside the printer. Before cleaning the printer, make sure you have turned off the power switch and unplugged the power cord from the outlet.

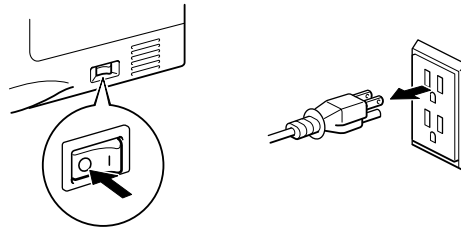

2. Press the Cover Release Button, and then open the Front Cover.

3. Pull the Drum Unit Assembly out of the printer.



Caution

Handle the drum unit carefully since it contains toner. If toner spills on your hands or cloths, wipe or wash it off immediately with water.

Note

We recommend that you put the drum unit on a piece of disposable paper or cloth in case you accidentally spill the toner.

4. Gently wipe the scanner window with a soft dry cloth.

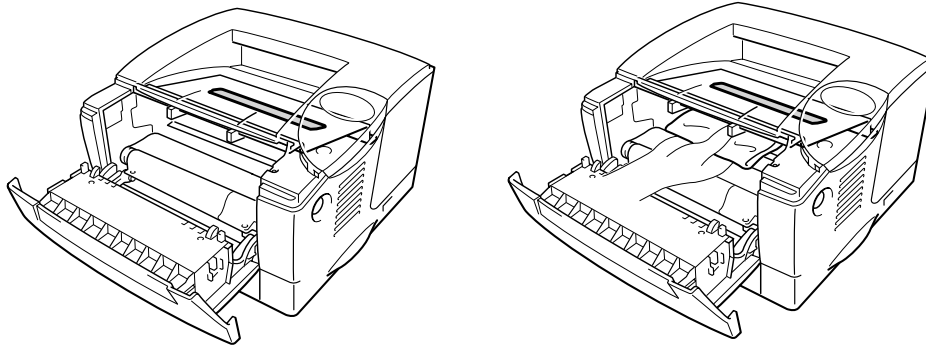
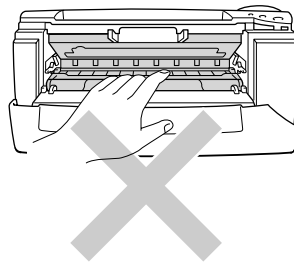

Fig. 5-9



Warning

After you have just used the printer, some internal parts of the printer are extremely **HOT!** When you open the covers of the printer, never touch the shaded parts shown in the following illustrations.



Caution

- Do not touch the scanner window with your fingers.
 - Do not wipe the scanner window with isopropyl alcohol.
-

5. Put the drum unit back into the printer. Close the Front Cover.

6. Plug in the power cord, and then turn on the power switch.

❖ **Cleaning the Corona Wire**

☞ **1** Press the Cover Release Button, and then open the Front Cover.

☞ **2.** Pull out the Drum Unit Assembly.

⚠ **Caution**

- We recommend that you put the drum unit Assembly on a piece of disposable paper or cloth in case you accidentally spill the toner.
- To prevent damage to the printer from static electricity, do not touch the electrodes shown below.

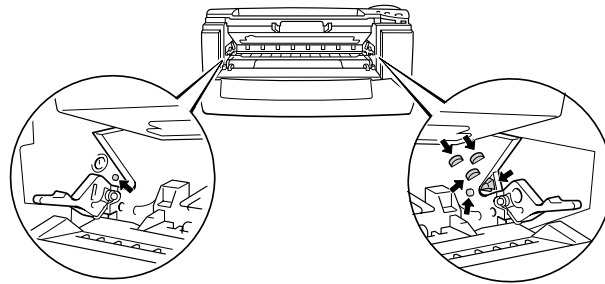

☞ **3.** Clean the Primary Corona Wire inside the drum unit by gently sliding the blue tab from right to left several times. Return the tab to the Home position (▲) before putting the drum unit back into the printer.

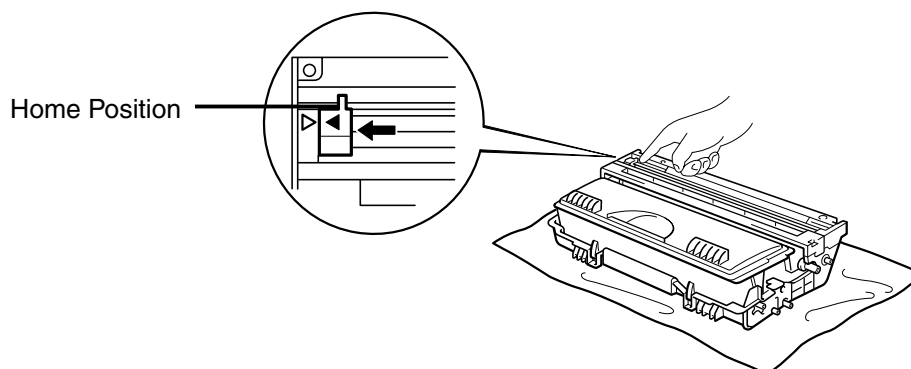



Fig. 5-10

 **Caution**

Be sure to position the tab to the Home position, or printed pages will have a thick vertical stripe.

 **4.** Put the drum unit back into the printer.

 **5.** Close the Front Cover.

Maintenance Messages

This printer will regularly prompt you to replace parts so you can rely upon it to maintain the best print quality.

| LCD Message | Item | Approximate Life | To Purchase Replacement |
|-----------------|-------------------|------------------------------|-------------------------|
| REPLACE FUSER | Fixing unit | 80,000 pages ^{**1} | Call Customer Support |
| REPLACE PF KIT1 | Paper feeding kit | 50,000 pages ^{**1} | Call Customer Support |
| REPLACE PF KIT2 | Paper feeding kit | 50,000 pages ^{**1} | Call Customer Support |
| REPLACE LASER | Scanner unit | 200,000 pages ^{**1} | Call Customer Support |

^{**1} At 5% print coverage (A4-Letter size). The actual number of printed pages may vary depending on the print jobs and paper you use.

CHAPTER 6

TROUBLESHOOTING

LCD Messages

Error Messages

| Operator Call Message | Action |
|-----------------------|--|
| TONER EMPTY | Replace the Toner Cartridge with a new one. See "Replacing the Toner Cartridge" in Chapter 5. |
| NO PAPER XXXX | Load paper into the indicated printer tray. |
| COVER OPEN | Close the Front Cover. |
| FUSER OPEN | Close the Jam Clear Cover. See illustration of the Jam Clear Cover in this chapter. |
| FACE UP OPEN | Close the Face Up Output Tray. |
| JAM XXXXXX | Remove the jammed paper from the indicated area. See "Paper Jams and How to Clear Them". |
| MANUAL FEED | Load the correct size of paper on the Multi-purpose Tray, and then press the GO button. |
| BUFFER ERROR | Check the Interface setting. |
| STORAGE FULL | Delete unnecessary macros or fonts. |
| DOWNLOAD FULL | Add the optional memory. See "Installing Additional Memory" in Chapter 4. |
| FONT FULL | Add the optional memory. See "Installing Additional Memory" in Chapter 4. |
| MEMORY FULL | Add the optional memory. See "Installing Additional Memory" in Chapter 4. |
| PRINT OVERRUN | <ul style="list-style-type: none"> Reduce the resolution, or add the optional memory. See "Installing Additional Memory" in Chapter 4. Set Page Protect to the correct size. |
| IGNORE DATA | Send correct data to the printer. |
| SIZE ERROR T1 | Set the correct paper that you want to use into the Tray1, or load the same size paper that you selected in the current driver setting. "What kind of paper can I use?" in Chapter 1. |

| | |
|------------------------|---|
| SIZE ERROR T2 | Set the correct paper that you want to use into the Tray2, or load the same size paper that you selected in the current driver setting. "What kind of paper can I use?" in Chapter 1. |
| SIZE ERROR DX | Specify the printable paper size. |
| NO DX TRAY | Install the Duplex Tray correctly. |
| DX LEVER ERROR | Set Paper Adjustment Lever for duplex printing. |
| NO TRAY1 | Install the standard paper cassette (Tray 1) into the printer. |
| CLEAN DRUM UNIT | Clean the corona wire. See "Cleaning the Corona Wire" in Chapter 5. |
| SIZE MISMATCH | <ol style="list-style-type: none"> 1. Put in the correct size of paper. 2. Select the correct size of paper on the Control Panel. |

Maintenance Messages

| Warning Message | Action |
|--------------------------|--|
| CHANGE DRUM SOON | The drum unit is almost at the end of its life. Prepare a new drum unit. See "CHANGE DRUM SOON Message" in Chapter 5. |
| TONER LOW | Prepare a new Toner Cartridge. See "TONER LOW Message" in Chapter 5. |
| REPLACE PF KIT1/2 | See "Maintenance Messages" in Chapter 5. |
| REPLACE FUSER KIT | See "Maintenance Messages" in Chapter 5. |
| REPLACE LASER KIT | See "Maintenance Messages" in Chapter 5. |

Service Call Messages

When any of the following messages appear on the LCD, turn the printer Off, wait 5 seconds, and then turn the printer On again. If this does not clear the problem, consult your dealer or an authorised Brother service representative.

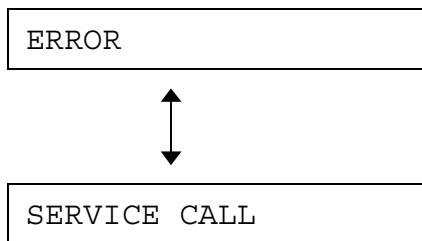

Troubleshooting Paper Handling

First, make sure that you are using paper that meets our recommended paper specifications. See “What Kind of Paper Can I Use?” in Chapter 1.

| Problem | Recommendation |
|--|---|
| The printer does not load paper. | <ul style="list-style-type: none"> • If there is paper in the paper cassette, make sure it is straight. If the paper is curled, you should straighten it before printing. Sometimes it is helpful to remove the paper, turn the stack over and place it back in the paper cassette. • Reduce the amount of paper in the paper cassette, and then try again. • Make sure that the MANUAL FEED = ON (STOP) is not selected on the control panel. |
| The printer does not load paper from the Multi-purpose Tray. | <ul style="list-style-type: none"> • Fan the paper, and then put the paper back in firmly. • Make sure that the MANUAL FEED = ON (STOP) is not selected on the control panel. |
| The printer does not load envelopes. | <ul style="list-style-type: none"> • The printer can load envelopes from the Multi-purpose Tray. Your application software must be set up correctly to print on the envelope size you are using. This is usually done in the page setup or document setup menu of your software. Please see your software application manual. |
| There is a paper jam. | <ul style="list-style-type: none"> • Clear the jammed paper (see “Paper Jams and How to Clear Them” in this chapter). |
| The printer does not print to the Face Down Output Tray. | <ul style="list-style-type: none"> • Close the Face Up Output Tray. |
| The printed pages are curled, so the Face Down Output Tray cannot hold the prescribed number of pages. | <ul style="list-style-type: none"> • Turn the paper in the Paper Cassette over. • Change the printer driver setting in Media Type to Transparencies from the current setting. |
| The printer does not print on the paper you have chosen. | <ul style="list-style-type: none"> • Make sure that the cable is connected to the printer • Make sure that you have chosen the appropriate printer driver. |

Paper Jams and How to Clear Them

When there is a paper jam in the printer, it will stop printing and display the following messages.

The shaded areas in the following illustrations show the locations of the jammed paper.

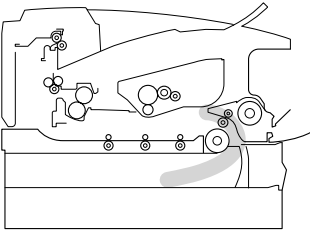
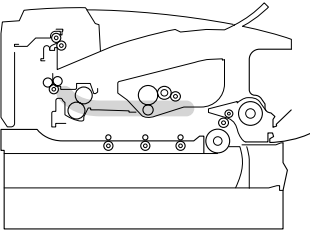
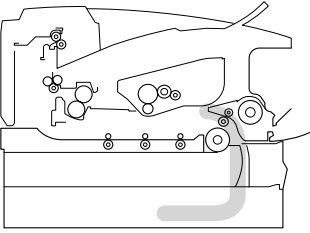
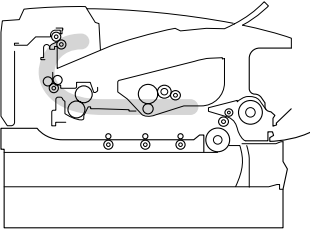
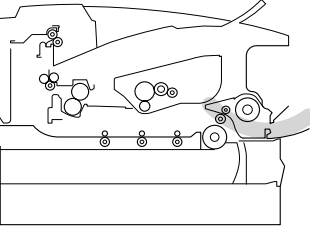
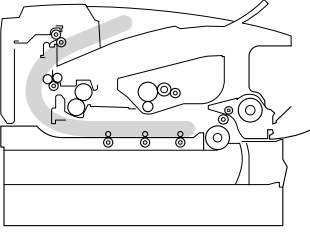
| | |
|---|---|
| JAM TRAY1 | JAM INSIDE |
|  |  |
| JAM TRAY2 | JAM REAR |
|  |  |
| JAM MP TRAY | JAM DUPLEX |
|  |  |
| PAPER JAM | |
| If you see the “PAPER JAM” error message, there are several possible places that the paper could have jammed. See the “PAPER JAM” section in this chapter for more information. | |

Find the location of the jammed paper and follow the instructions to remove it.

After you have followed the instructions, the printer will automatically resume printing.

JAM TRAY1

JAM TRAY1

Follow the instructions below to clear a paper jam:

1. Pull the Paper Cassette completely out of the printer.

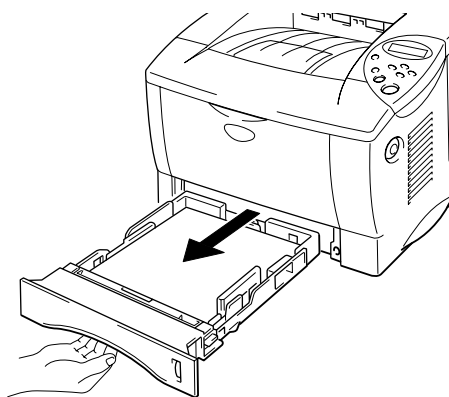

Fig. 6-1

2. Pull the jammed paper out of the printer.

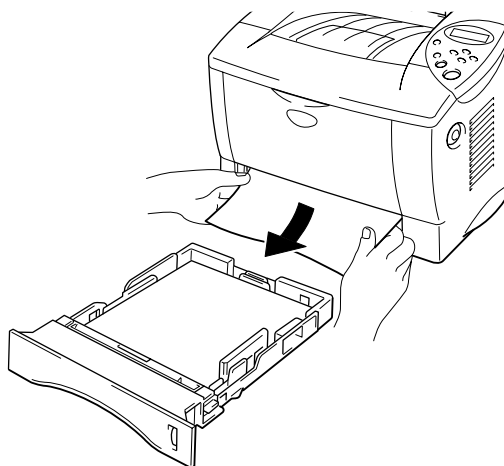

Fig. 6-2

☛ 3. Put the paper cassette back into the printer.

⚠ **Caution**

Do not pull out the standard Paper Cassette (Tray 1) while paper is being fed from the Optional Lower Paper Cassette, as this will cause a paper jam.

JAM TRAY2

JAM TRAY2

Follow the instructions below to clear the paper jam:

1. Pull the lower paper cassette completely out of the printer.

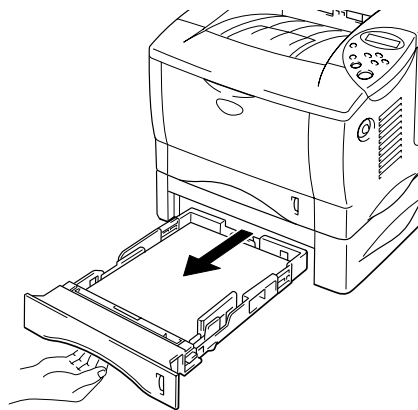

Fig. 6-3

2. Using both hands, pull the jammed paper out of the printer.

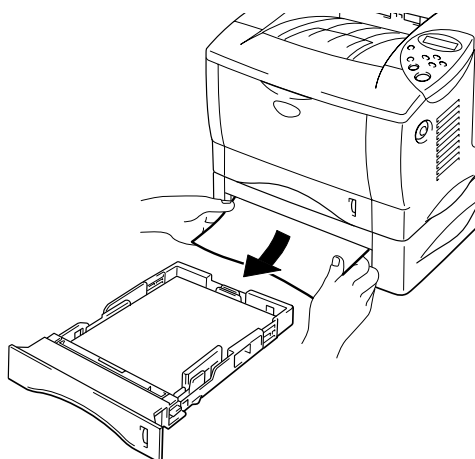

Fig. 6-4

3. Put the lower paper cassette back into the printer.

JAM MP TRAY

JAM MP TRAY

Follow the instructions below to clear a paper jam:

1. Remove the jammed paper from the Multi-purpose Tray.

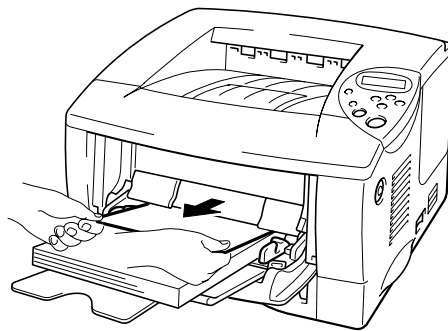

Fig. 6-5

2. Put all the paper back into the Multi-purpose Tray correctly.

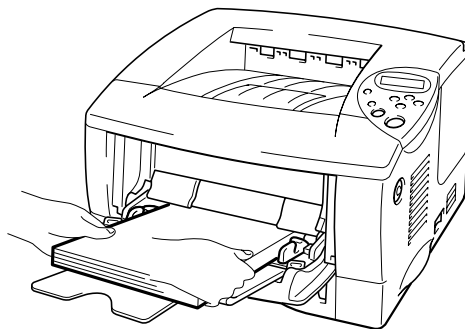

Fig. 6-6

JAM INSIDE

JAM INSIDE

Follow the instructions below to clear the paper jam:

1. Press the Cover Release Button, and then open the Front Cover.

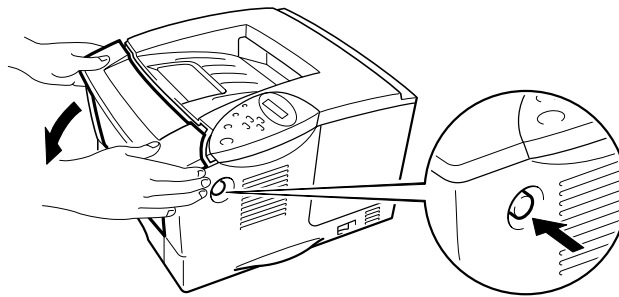

Fig. 6-7

2. Pull the Drum Unit Assembly out of the printer. Pull the Paper Cassette completely out of the printer.
3. Pull the jammed paper up and out of the printer.

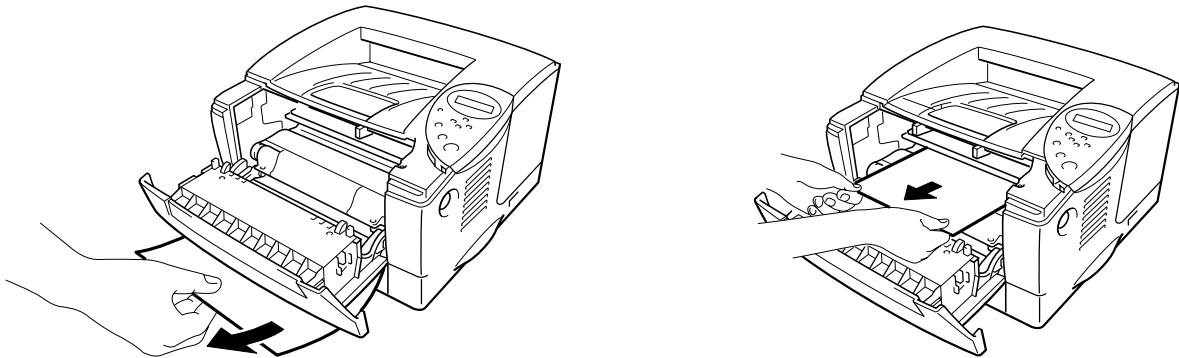

Fig. 6-8



Warning

The fixing roller is extremely **hot** during operation. Remove the paper carefully.



Caution

- After you remove the jammed paper, if the printed page has a stain, print several pages before restarting your print job.
 - Remove the jammed paper carefully so you don't spread toner.
 - Take care not to stain your hands and clothes with toner. Immediately wash toner stains with cold water.
 - Never touch the transfer roller.
-

4. Press the Lock Lever down, and then pull the Toner Cartridge out of the Drum Unit Assembly. Remove any paper that may be jammed inside the Drum unit.

5. Put the Toner Cartridge into the Drum Unit until you hear it lock into place with a click.

6. Put the Drum unit and Paper Cassette back into the printer. Close the Front Cover.

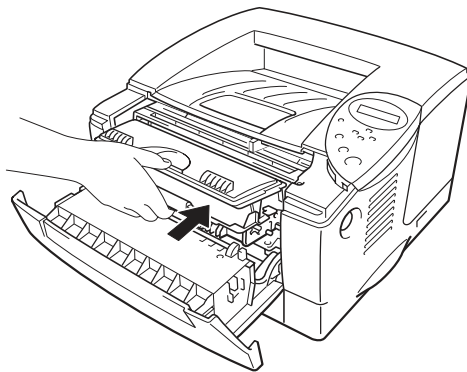

Fig. 6-9

JAM REAR

JAM REAR

Follow the instructions below to clear a paper jam:

1. Press the Cover Release Button, and then open the Front Cover.
2. Pull the Drum Unit Assembly out of the printer.

⚠ **Caution**

- We recommend that you put the Drum Unit Assembly on a piece of disposable paper or cloth so you don't accidentally spill the toner.
- To prevent damage to the printer caused by static electricity, do not touch the electrodes shown below.

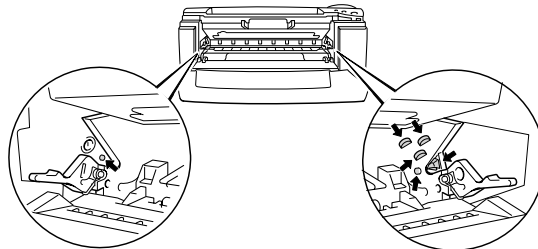

- ☛ 3. Pull the jammed paper out of the printer.

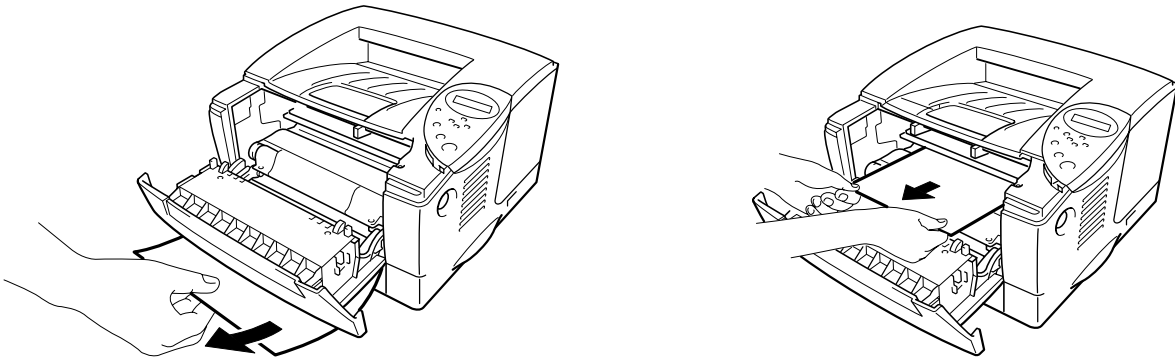

Fig. 6-10

If the paper jam can be cleared, go to Step 7.

- ☛ 4. Open the Face Up Output Tray.

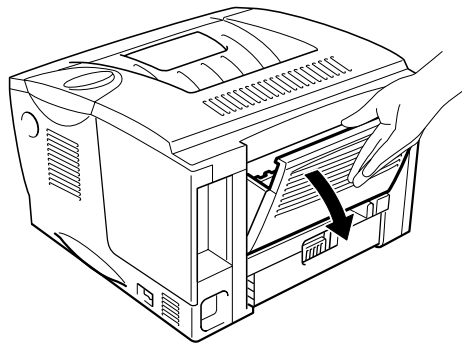
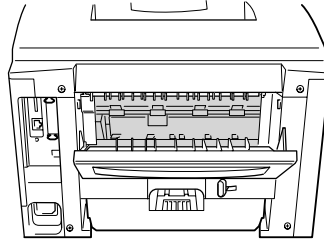

Fig. 6-11

! **Caution**

After you have just used the printer, some internal parts of the printer are extremely **hot!** Wait for the printer to cool down before you touch the internal parts of the printer.



5. Open the Jam Clear Cover. Pull the jammed paper out of the fuser unit.

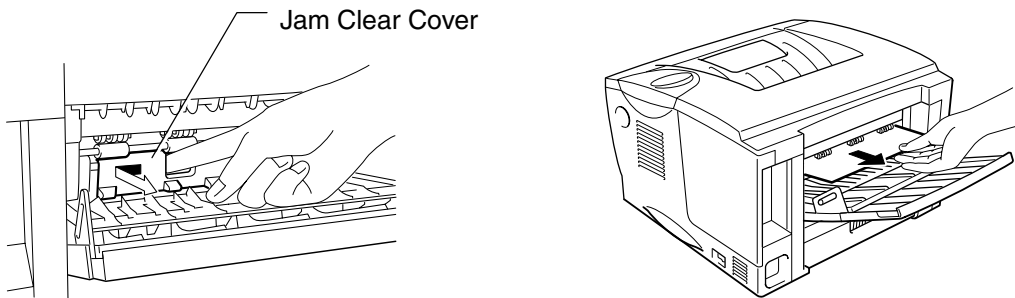

Fig. 6-12

6. Close the Jam Clear Cover. Close the Face Up Output Tray.

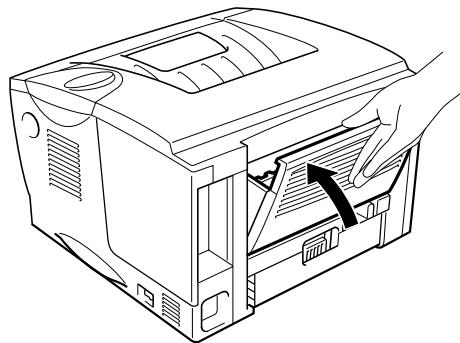



Fig. 6-13

 **7.** Put the drum unit back into the printer.

 **8.** Close the Front Cover.

JAM DUPLEX

JAM DUPLEX

Follow the instructions below to clear a paper jam:

1. Open the Face Up Output Tray.

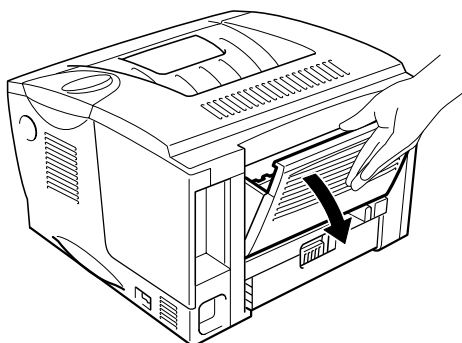

Fig. 6-14

2. Pull the jammed paper out of the fuser unit.

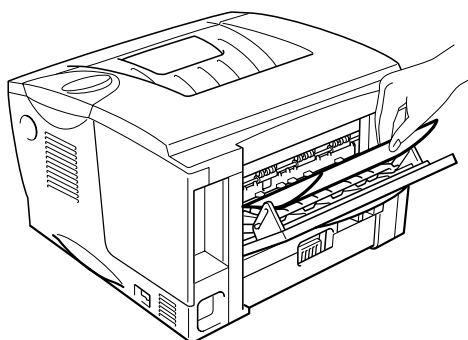

Fig. 6-15

- 3. Close the Face Up Output Tray.

If the paper jam cannot be cleared, go to the next step.

- 4. Pull the Duplex Tray and Paper Cassette out of the printer.

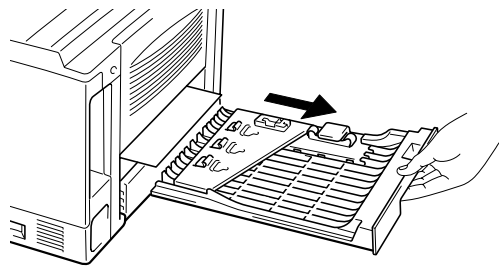

Fig. 6-16

- 5. Pull the jammed paper out of the printer.

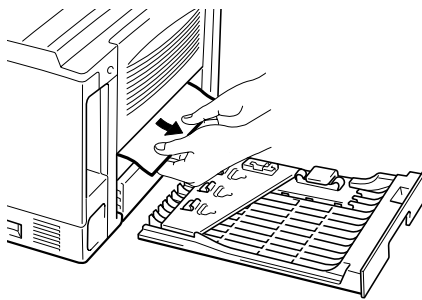

Fig. 6-17

6. Put the Duplex Tray and Paper Cassette back into the printer.

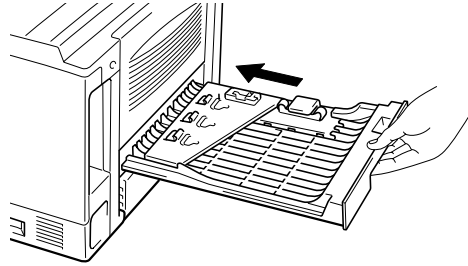

Fig. 6-18

•• **Note**

-
- The JAM DUPLEX message appears if you remove a sheet of paper from the Face Down Output Tray after only one side has printed.
 - The paper sizes you can use for the Duplex Printing function are A4, Letter and Legal.
 - If the Paper Adjustment Lever for Duplex Printing is not set correctly for the paper size, paper jams may occur and the printing will be out of position on the page.
-

PAPER JAM

PAPER JAM

Follow the instructions below to clear a paper jam:

1. Pull the Paper Cassette completely out of the printer.
2. Pull the jammed paper out of the printer.

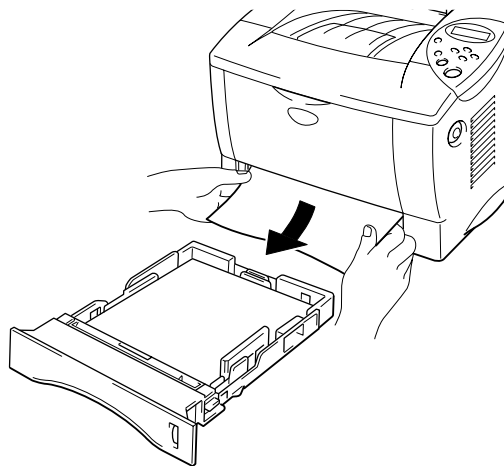

Fig. 6-19

If the paper jam can be cleared, go to Step 10.

3. Press the Cover Release Button, and then open the Front Cover.

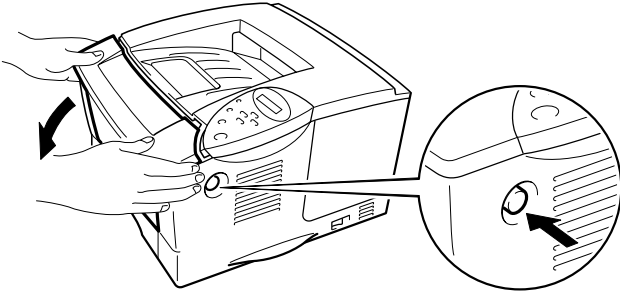

Fig. 6-20

4. Pull the drum unit completely out of the printer. Pull the jammed paper up and out of the printer.

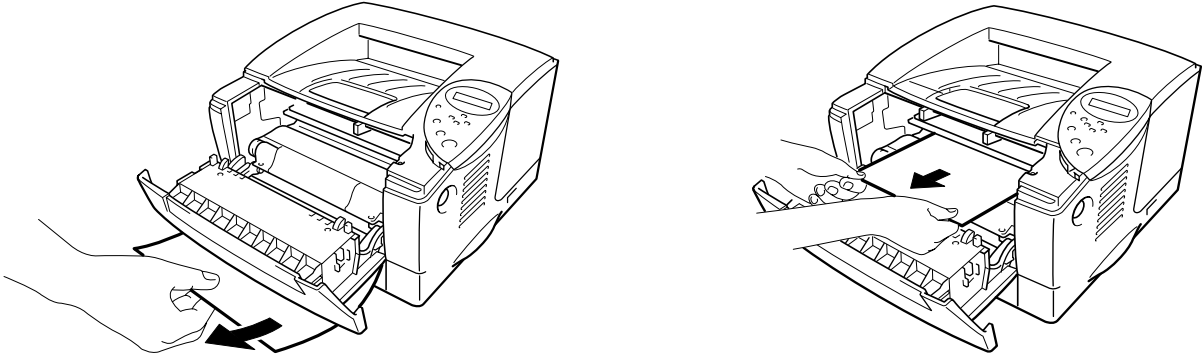

Fig. 6-21

If the paper jam can be cleared, go to Step 8.

5. Open the Face Up Output Tray.

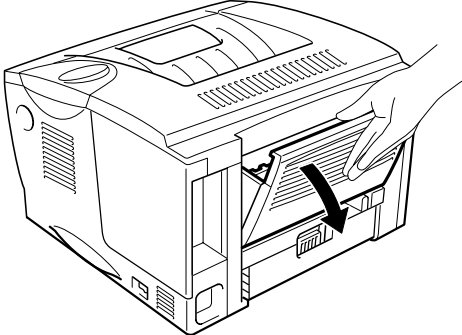

Fig. 6-22

6. Open the Jam Clear Cover. Pull the jammed paper out of the fuser unit.

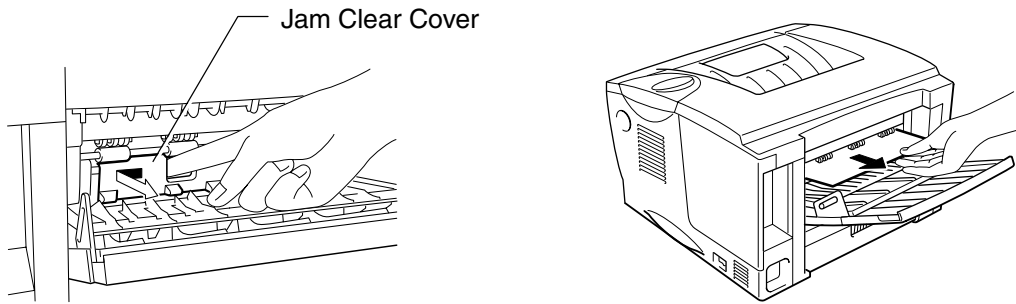

Fig. 6-23

7. Close the Jam Clear Cover. Close the Face Up Output Tray.



8. Put the drum unit back into the printer.

9. Close the Front Cover.

10. Put the Paper Cassette back in the printer.

Improving the Print Quality

This section provides information on the following topics:

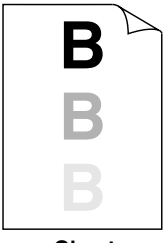
| Image Defect Examples | Recommendation |
|--|--|
|  <p>ABCDEF GH abcde fghijk A B C D a b c d e 0 1 2 3 4</p> <p>Faint</p> | <ul style="list-style-type: none"> • Check the printer's environment. Conditions such as humidity and high temperatures may cause this print defect to occur. See "Place the Printer" in Chapter 1. • If the whole page is too light, toner save mode may be on. Turn the toner save mode off on the Printer Properties tab of the Driver. • Try using a new Toner Cartridge. See "Replacing the Toner Cartridge" in Chapter 5. • Increase the Print Density by using the QUALITY mode on the printer control panel. See "Control Panel Menus" in Chapter 3. |
|  <p>ABCDEF GH abcde fghijk A B C D a b c d e 0 1 2 3 4</p> <p>Gray Background</p> | <ul style="list-style-type: none"> • Make sure you use paper that meets our recommended specifications. See "Recommended Paper" in Chapter 1. • Check the printer's environment; high temperature and high humidity can increase the amount of background shading. See "Positioning the Printer" in Chapter 1. • Use a new Toner Cartridge. See "Replacing the Toner Cartridge" in Chapter 5. |
|  <p>B B B</p> <p>Ghost</p> | <ul style="list-style-type: none"> • Make sure you use paper that meets our specifications. Rough paper, paper that has absorbed moisture, or thick paper can cause the problem. See "What Kind of Paper Can I Use?" in Chapter 1. • Make sure that you chose the appropriate media type in the printer driver. See "What Kind of Paper Can I Use?" in Chapter 1. • The drum unit may be damaged. Install a new drum unit. See "Replacing the drum unit" in Chapter 5. • The toner cartridge may be damaged. Put in a new toner cartridge. See "Replacing the Toner Cartridge" in Chapter 5. • The fixing unit may be smudged. Call Customer Support. |

| Image Defect Examples | Recommendation |
|---|--|
|  <p data-bbox="304 506 448 528">Toner Specks</p> | <ul data-bbox="627 253 1422 577" style="list-style-type: none"> • Make sure you use paper that meets our specifications. Rough paper may cause this problem. See "What Kind of Paper Can I Use?" in Chapter 1. • The drum unit may be damaged. Install a new drum unit. See "Replacing the drum unit" in Chapter 5. • The toner cartridge may be damaged. Put in a new toner cartridge. See "Replacing the Toner Cartridge" in Chapter 5. • The fixing unit may be smudged. Call Customer Support. |
|  <p data-bbox="312 842 438 864">Hollow Print</p> | <ul data-bbox="627 607 1449 875" style="list-style-type: none"> • Make sure you use paper that meets our specifications. See "What Kind of Paper Can I Use" in Chapter 1. • Chose the 'Thick Paper Mode' in the printer driver, or use thinner paper than you are currently using. • Check the printer's environment because conditions such as high humidity may cause this problem. See "Positioning the Printer" in Chapter 1. |
|  <p data-bbox="328 1155 427 1178">All Black</p> | <ul data-bbox="627 902 1401 1115" style="list-style-type: none"> • The drum unit may be damaged. Put in a new drum unit. See "Replacing the drum unit" in Chapter 5. • Clean the Corona Wire. See "Cleaning the Corona Wire" in Chapter 5. • The fixing unit may be smudged. Call Customer Support. |

Image Defect Examples | **Recommendation**



White Spots

Printed pages have white spots in black text and graphics at intervals of 94 mm (3.7 in.).

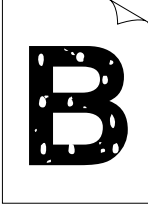
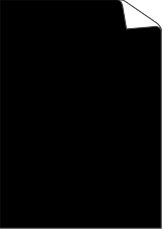
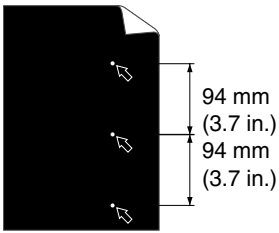
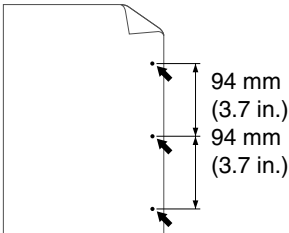

Black Spots

Printed pages have black spots at intervals of 94 mm (3.7 in.).

- If the problem is not sorted out after printing a few pages, there may be glue on the drum surface.
- Clean the drum unit as follows:
 1. Position the print sample in front of the drum unit, and find the exact position of the image fault.

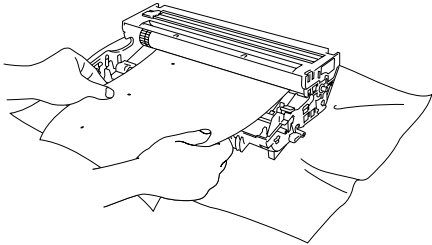

Fig. 6-31

2. Turn the drum unit gear by hand while looking at the surface of the drum.

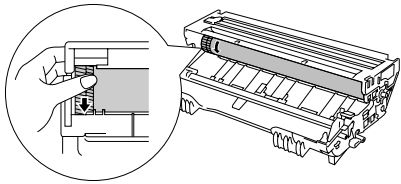

Fig. 6-32

3. When you have found the mark on the drum that matches the print sample, wipe the surface of the drum with a dry cotton swab until the dust or paper powder on the surface comes off.

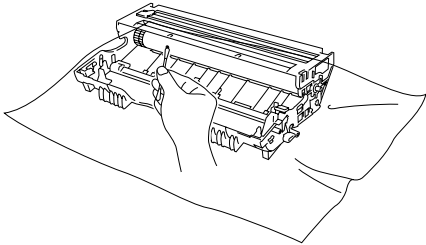
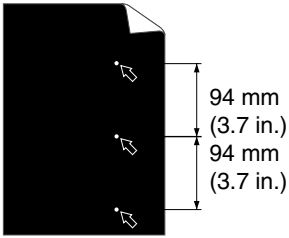

Fig. 6-33

| Image Defect Examples | Recommendation |
|-----------------------|----------------|
|-----------------------|----------------|



White Spots

Printed pages have white spots in black text and graphics at intervals of 94 mm (3.7 in.).

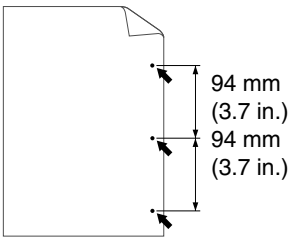





Printed pages have black spots at intervals of 94 mm (3.7 in.).

! Caution

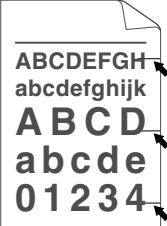
Do not try to clean the surface of the drum with anything sharp, such as a ballpoint pen.

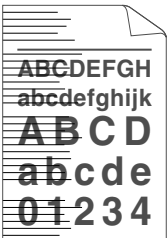
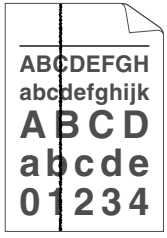
- The drum unit may be damaged. Put in a new drum unit. See [“Replacing the drum unit” in Chapter 5.](#)

| Image Defect Examples | Recommendation |
|---|--|
|  <p>Black Horizontal Repetitive Defects Toner scatters and stains the printed page.</p> | <ul style="list-style-type: none"> The drum unit may be damaged. Put in a new drum unit. See "Replacing the drum unit" in Chapter 5. Make sure you use paper that meets our specifications. See "What Kind of Paper Can I Use?" in Chapter 1. <p>Note</p> <ul style="list-style-type: none"> If you use label sheets for laser printers, the glue from the sheets may sometimes stick to the drum surface. Clean the drum unit. See the previous page. Do not use paper that has clips or staples because they will scratch the surface of the drum. If the unpacked drum unit is in direct sunlight or room light, it may be damaged. |
|  <p>White Horizontal Stripes</p> | <ul style="list-style-type: none"> Make sure you use paper that meets our specifications. Rough or thick paper can cause the problem. See "What Kind of Paper Can I Use?" in Chapter 1. Make sure you chose the appropriate media type in the printer driver. The problem may disappear by itself. Try printing a few pages to clear this problem especially if you have not used the printer for a long time. The drum unit may be damaged. Put in a new drum unit. See "Replacing the drum unit" in Chapter 5. |
|  <p>Horizontal Lines</p> | <ul style="list-style-type: none"> The Drum Unit may be damaged. Put in a new Drum Unit. See "Replacing the drum unit" in Chapter 5. |
|  <p>Black Vertical Lines Printed pages are stained with toner or have vertical stripes.</p> | <ul style="list-style-type: none"> The Toner Cartridge may be damaged. Put in a new Toner Cartridge. See "Replacing the Toner Cartridge" in Chapter 5. The fixing unit may be smudged. Call Customer Support. Clean the Corona Wire. See "Cleaning the Corona Wire" in Chapter 5. Return the tab on the drum unit to the Home position. |

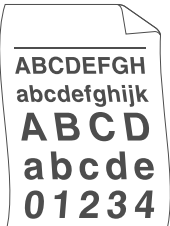
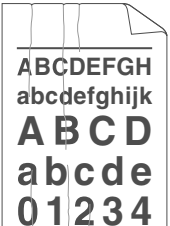
| Image Defect Examples | Recommendation |
|--|---|
|  <p data-bbox="261 562 489 584">White Vertical Streaks</p> | <ul data-bbox="627 309 1430 544" style="list-style-type: none"> • You may clear the problem by wiping the scanner window with a soft cloth. See "How to Clean the Printer" in Chapter 5. • Make sure that there are no piece of paper inside the printer covering the scanner window. • The Toner cartridge may be damaged. Put in a new Toner cartridge. See "Replacing the Toner Cartridge" in Chapter 5. |
|  <p data-bbox="317 887 437 909">Page Skew</p> | <ul data-bbox="627 600 1445 1070" style="list-style-type: none"> • Make sure the paper or other media is loaded into the paper cassette correctly and that the guides are not too tight or too loose against the paper stack. • Set the paper guides correctly. Make sure that the tips of the paper guides fit into the slots correctly. See "Printing from the Paper Cassette" in Chapter 1. • If you are using the Multi-purpose Tray, see "Printing from the Multi-purpose Tray" in Chapter 1. • The Paper Cassette may be too full. See "Printing from the Paper Cassette" in Chapter 1 • Check the paper type and quality. See "What Kind of Paper Can I Use?" in Chapter 1. |
|  <p data-bbox="308 1361 446 1384">Curl or Wave</p> | <ul data-bbox="627 1104 1445 1350" style="list-style-type: none"> • Check the paper type and quality. High temperatures and humidity will cause paper to curl. See "What Kind of Paper Can I Use?" in Chapter 1. • If you don't use the printer very often, the paper may have been in the paper cassette for too long. Turn over the stack of paper in the paper cassette. Also, try rotating the paper 180° in the paper cassette. |
|  <p data-bbox="272 1704 481 1727">Wrinkles or Creases</p> | <ul data-bbox="627 1440 1445 1675" style="list-style-type: none"> • Make sure that paper is loaded properly. See "Printing from the Paper Cassette" in Chapter 1. • Check the paper type and quality. See "What Kind of Paper Can I Use" in Chapter 1. • Turn over the stack of paper in the tray or try rotating the paper 180° in the tray. |

How to Print Correctly

| Problem | Recommendation |
|--|--|
| <p>The printer prints unexpectedly or it prints garbage.</p> | <ul style="list-style-type: none"> • Make sure the printer cable is not too long. We recommend you use a parallel cable that is less than 2 metres (6 1/2 feet) long. • Check if the printer cable is damaged or broken. • If you are using an interface-switching device, remove it, and then connect your computer directly to your printer and try again. • Check that you have chosen the appropriate printer driver as 'Set as Default'. • Check that the printer is not connected to the same port that is also connected to a storage device or scanner. Remove all other devices and connect the port to the printer only. • Turn off the status monitor in the Device / Options page on the Advanced tab in the printer driver. |
| <p>The DL size of envelopes that have been creased after they were printed.</p> | <ul style="list-style-type: none"> • Put in new DL size envelopes sideways, and print again. Refer to 'Printing Envelopes' in Chapter 1. |
| <p>The printer cannot print full pages of a document. An error message "PRINT OVERRUN" occurs.</p> | <ul style="list-style-type: none"> • Press the Go button to print the data that is left in the printer. • If this does not clear the error, reduce the complexity of your document or reduce the print resolution. • Change the following settings in the supplied Windows® driver, and then try again. The best combination of settings below will vary depending on your document. <ul style="list-style-type: none"> • Graphics mode • TrueType mode • Use Printer TrueType Fonts |
| <p>The printer cannot print full pages of a document. A "MEMORY FULL" error message occurs.</p> | <ul style="list-style-type: none"> • Press the Go button to print the data that is left in the printer. • Reduce the print resolution or reduce the complexity of your document. • Expand the printer memory by adding a commercially available DIMM. Refer to 'RAM Expansion' in Chapter 4. |

| Problem | Recommendation |
|--|--|
| MY headers or footers appear when I view my document on the screen but they do not show up on printed pages. | <ul style="list-style-type: none"> • Most laser printers have a restricted area that cannot be printed on. Usually the first two lines and the last two lines of a page cannot have print (leaving 62 printable lines). Adjust the top and bottom margins of your document to allow for this. |

Other Problems

| Problem | Recommendation |
|--|--|
| The printer cannot print. "There was an error writing to LPT1: (or BRUSB) for the printer." error message occurs on your PC. | <ul style="list-style-type: none"> • Check that the printer cable is not damaged or broken. • If you have an interface-switching device, make sure that the correct printer is selected. |

For DOS Users

| Problem | Recommendation |
|--|---|
| Unable to print from application software. | <ul style="list-style-type: none"> • Check that the DOS application software interface settings match that of your printer. For example, if you are using a parallel printer cable, you would most likely set your DOS software printer port to LPT1. • Check if the printer has any printer alarms. • Check that you have chosen the appropriate printer driver in your application software. |

BR-Script 3 Language

| Problem | Recommendation |
|------------------------------------|---|
| The printer cannot print. | If "IGNORE DATA" appears on the LCD message, please do the following: <ol style="list-style-type: none"> 1. Reset the printer. 2. Set "ERRORPRINT" to ON, and print again. 3. If the Error is "LIMITCHECK," add the optional memory. See "Installing Additional Memory" in Chapter 4. |
| The print speed slows down. | Add the optional memory. See "Installing Additional Memory" in Chapter 4. |
| The printer cannot print EPS data. | You need the following settings to print this type of data: <ol style="list-style-type: none"> 1. Select the printer you use in the Printer folder. 2. Press the "Advanced" button on the PostScript tab. 3. Select the "Tagged binary communication protocol" in the Data format section. |

APPENDIX

Printer Specifications

| ENGINE | | |
|-------------------------|--|---|
| Technology | | Electrophotographic |
| Print Speed | Normal | Letter: 19 ppm A4: 18 ppm |
| | Duplex Printing | Up to 8.5 ppm |
| First Print Time | | Less than 12 sec ¹ |
| | Windows® 95 / 98 / Me / Windows NT® 4.0 / Windows® 2000 / Windows® XP | HQ1200 ^{2*3} 600 dpi 300 dpi |
| | DOS | 600 dpi |
| | Mac® OS 8.6 to 9,2/ Mac® OS X 10.1 | HQ1200 ^{2*3} 600 dpi 300 dpi |
| | HRC ⁴ | For 300 / 600 dpi |
| | APT ⁵ | Yes (Windows® only) |

| CONTROLLER | | | |
|-----------------------------|--------------------------|----------|--|
| Processor | | | Fujitsu MB86834 100MHz |
| | | HL-1850 | 16MB |
| | | HL-1870N | 32MB |
| | Option | HL-1850 | 1 DIMM (100pin) slot (16, 32, 64, 128MB); expandable up to 144MB |
| | | HL-1870N | 1 DIMM (100pin) slot (16, 32, 64, 128MB); expandable up to 144MB |
| Interface | Standard | HL-1850 | IEEE 1284 Parallel, USB, |
| | | HL-1870N | IEEE 1284 Parallel, USB, 10/100 Base TX (NC-4100h) |
| | Option | HL-1850 | 10/100 Base TX (NC-4100h), IrDA (IR-1000) |
| | | HL-1870N | IrDA (IR-1000) |
| Network Connectivity | Interface | | 10/100 Base TX (option for HL-1850, standard for HL-1870N) |
| | Protocol | | TCP/IP, EtherTalk, IPX/SPX, DEC LAT, Banyan VINES, NetBEUI, DLC/LLC |
| | Management Tool | | BRAdmin Professional ⁶ Web Based Management ⁷ |
| Emulation | | | PCL6, BR-Script 3 ⁸ , IBM Proprinter XL, Epson FX-850 |
| Resident Fonts | PCL | | 66 scalable fonts, 12 bitmap fonts, 11 bar codes ⁹ |
| | BR-Script 3 ⁸ | | 66 fonts |
| | Option | | 136 Agfa PS3 fonts ¹⁰ |

| SOFTWARE | |
|-------------------------|---|
| Printer Driver | PCL Driver for Windows® 95 / 98 / Me, Windows NT® 4.0, Windows® 2000 and Windows® XP BR-Script 3 ^{*8} (PPD file for Windows® 95 / 98 / Me, Windows NT® 4.0, Windows® 2000, Windows® XP and Macintosh ^{*11}) |
| Utility Software | Internet Print software ^{*12} Storage Manager ^{*13} |

| CONTROL PANEL | | |
|----------------|-----------|--|
| Display | LCD | 1 line, 16 Digits, 3 colors |
| | LED | 1 LED |
| Buttons | 7 Buttons | Go, Job Cancel, Reprint, Set, Back, and 2 scroll buttons |

| PRINTER DRIVER FUNCTIONS | | |
|--------------------------|--------------------|----------------------------------|
| Page Layout | N-up Printing | 2, 4, 9, 16, 25 in 1 page |
| | Poster Printing | 1 in 4, 9, 16, 25 |
| | Watermark Printing | Yes |
| | Booklet Printing | Yes |
| Other | | Quick Print Setup ^{*14} |

| SUPPLIES | |
|--------------|--|
| Toner | Up to 6,500 A4/LTR pages @5% coverage |
| Drum | Up to 20,000 A4/LTR pages (1 page / job) |

| DIMENSIONS / WEIGHTS | | |
|----------------------|----------|---|
| Dimensions | | 425 (W) x 424(D) x 275 (H) mm (16.7" x 16.7" x 10.8") |
| Weights | HL-1850 | Approx. 14.5 kg (32.0 lbs.) including the drum unit and toner cartridge |
| | HL-1870N | Approx. 14.7 kg (32.4 lbs.) including the drum unit and toner cartridge |

| OTHERS | | |
|---------------------------|------------|---|
| Power Consumption | Printing | Less than 410 W |
| | Standby | Less than 70 W |
| | Sleep | HL-1850 : Less than 9 W HL-1870N : Less than 10 W (Default activation time : 5 mintues) |
| | Off | Less than 0.25 W (The only way to achieve 0 W power consumption is to unplug the power cord from the AC outlet.) |
| Noise Level | Printing | Less than 50 dB |
| | Standby | Less than 30 dB |
| Noise per ISO 9296 | Printing | Lwad = 67dB (A) You might want to install printers with a sound power level of Lwad 63 dB (A) or more in a separate room or cubicle. |
| | Standby | Lwad = 43dB (A) |
| Ecology | Power Save | Yes |
| | Toner Save | Yes |

- *1 From standard Paper Cassette
- *2 Brother HQ1200 technology provides the best print quality while printing at full engine speed.
- *3 On BR-Script driver (PPD file) with Mac OS 8 or later
- *4 High Resolution Control
- *5 Advanced Photoscale Technology
- *6 Original Windows® utility for print server management
- *7 Printer and print server management through Web Browser
- *8 PostScript 3 language emulation
- *9 Code39, Interleaved 2 of 5, EAN-8, EAN-13, UPC-A, UPC-E, EAN-128, Codabar, FIM(US-PostNet), ISBN, Code128
- *10 Total number of PS3 fonts is 165 (136 Agfa fonts + 29 original fonts)
- *11 EtherTalk only
- *12 Utility software to print at this printer from a remote computer via the Internet.
(For Windows® 95 / 98 / Me, NT® 4.0 / 2000 / XP)
- *13 Utility software to manage fonts and macros (electronic forms) stored in the printer memory.
(For Windows® 95 / 98 / Me, NT® 4.0 / 2000 / XP)
- *14 A printer driver function that enables you to change the driver settings without opening the Property dialog.

Print Media and Size

The paper trays and LCD panel descriptions in this manual are named as shown below.

| | |
|---------------------|---------|
| Upper Paper Tray | Tray 1 |
| Multi-purpose Tray | MP Tray |
| Optional Lower Tray | Tray 2 |

The printer loads paper from the installed Multi-purpose Tray, Upper Paper Tray or the Optional Lower Paper Tray.

| Media Type | Tray 1 | MP Tray | Tray 2 | Duplex Printing | Select the Media Type in the Printer Driver |
|-----------------------|---------------|----------------|---------------|------------------------|--|
| Plain Paper | ✓ | ✓ | ✓ | ✓ | Plain paper |
| Recycled Paper | ✓ | ✓ | ✓ | ✓ | Plain paper |
| Bond Paper | ✓ | ✓ | ✓ | | Bond paper |
| Thick Paper | | ✓ | | | Thick paper or Thicker paper |
| Transparencies | | ✓ | | | Transparencies |
| Label | | ✓ | | | Plain paper |
| Envelopes | | ✓ | | | Envelopes Envelopes – Thin Envelopes – Thick |
| Card Stock | ✓ | ✓ | | | Thick paper or Thicker paper |

| | Upper Paper Tray (Tray 1) | Multi-purpose Tray (MP Tray) | Optional Lower Tray Unit (Tray 2) | Duplex Printing |
|-------------------|--|--|--|------------------------|
| Paper Size | A4, Letter, Legal, 8.5 x 13 in., B5 (JIS), B5 (ISO), Executive, A5, A6, B6 | Width: 70 to 216 mm (2.75 to 8.5 in.) Length: 116 to 356 mm (4.57 to 14.0 in.) | A4, Letter, Legal, B5 (JIS), B5 (ISO), Executive, A5 | A4, Letter, Legal |
| Capacity | 250 sheets (80 g/m ² or 21 lbs.) | 100 sheets (80 g/m ² or 21 lbs.) Legal: 30 8.5 x 13 in.: 30 labels: 10 | 250 sheets (80 g/m ² or 21 lbs.) | |

We recommend the following print methods (output tray) for each paper media type:

| Media Type | Paper Output | | Notes |
|-----------------------|---------------------|----------------|---|
| | Face Down | Face up | |
| Plain Paper | ✓ | ✓ | 60 g/m ² to 105 g/m ² (16 to 28 lbs.) |
| Thick Paper | | ✓ | 105 g/m ² to 161 g/m ² (28 to 43 lbs.) |
| Recycled Paper | ✓ | ✓ | |
| Transparencies | ✓ | | OHP films |
| Label | | ✓ | |
| Envelopes | | ✓ | |
| Card Stock | | ✓ | |

You can select the priority of the paper source by using the Paper menu on the printer control panel.

For more information about the paper settings, see Chapter 3.

What Is Important When You Choose Paper to Use with This Printer

◆ *Before You Purchase a Large Quantity of Paper*

Make sure that the paper is suitable for the printer.

◆ *Paper for Plain Paper Copies*

Paper is divided by usage, such as paper for printing and paper for copying. The usage is usually shown on the paper's package. Check the package to see whether it is suitable for laser printers. You must use paper that is suitable for laser printers.

◆ *Basis Weight*

The basis weight of the paper for general use varies in different countries. We recommend that you use paper that weighs 75 g/m² to 90 g/m² (20 to 24 lb.), although this printer is able to cope with thinner or thicker paper than these weights.

| Unit | Europe | USA |
|------------------|----------|----------|
| g/m ² | 80 to 90 | 75 to 90 |
| lb | | 20 to 24 |

◆ *Long Grain and Short Grain*

Though most plain paper for copying is long grain, some is short grain. We recommend that you use long grain paper for this printer. Short grain paper is too weak to be carried through the printer.

◆ ***Acid Paper and Neutralized Paper***

Paper can be classified as either acid paper or neutralized paper. Modern methods for making paper started with acid paper, but neutralized paper is taking the place of acid paper because of environmental or preservation issues.

However, many forms of acid paper can be found in recycled paper. We recommend that you use neutralized paper for this printer.

You can use an acid paper check pen to distinguish acid paper from neutral paper.

◆ ***Print Surface***

The characteristics may differ a little between the face side and reverse side of a sheet of paper.

Usually, the opening side of the ream of paper package is the print side.

Follow any indication of the print side on the paper package. Typically, the paper side is indicated with an arrow.

◆ ***Moisture Content***

Moisture content is the amount of water left in the paper after it has been made. It is one of the important characteristics of the paper. This can change greatly depending on where the paper is stored, although usually paper is 5% water by weight. Because paper often absorbs water, the amount of water can sometimes be about 10% in a high humidity environment. When the amount of water increases, the characteristic of the paper changes greatly. The fixing of the toner may become worse. For storing of the paper and during use, we recommend that the humidity of the surrounding environment is between 50% and 60%.

Rough estimate of basis weight

| g/m ² | Lbs | |
|------------------|------|-------|
| | Bond | Index |
| 60 | 16 | |
| 64 | 17 | |
| 75 | 20 | |
| 90 | 24 | |
| 105 | 28 | |
| 120 | 32 | |
| 135 | 36 | |
| 161 | 43 | 90 |
| 200 | 53 | 110 |

Paper size

| | | |
|------------------|--------------|------------------|
| Letter | | 8.5 x 11 in. |
| Folio | | 8.5 x 13 in. |
| Legal | | 8.5 x 14 in. |
| Executive | | 7.25 x 10.5 in. |
| A4 | 210 x 297 mm | |
| A5 | 148 x 210 mm | |
| A6 | 105 x 148 mm | |
| B5 (JIS) | 182 x 257 mm | |
| B6 (ISO) | 125 x 176 mm | |
| B5 (ISO) | 176 x 250 mm | |
| Envelope Monarch | | 3.875 x 7.5 in. |
| Envelope #9 | | 3.875 x 8.9 in. |
| Envelope #10 | | 4.12 x 9.5 in. |
| Envelope #11 | | 4.5 x 10.375 in. |
| Envelope DL | 110 x 220 mm | |
| Envelope C5 | 162 x 229 mm | |
| Envelope C6 | 114 x 162 mm | |
| Envelope B5 | 176 x 250 mm | |
| Envelope B6 | 176 x 125 mm | |

Emulation Modes

This printer has the following emulation modes:

❖ **HP LaserJet Mode**

This printer uses the HP LaserJet mode (or HP mode) that emulates the Hewlett-Packard LaserJet laser printer. Since many application software packages support the HP LaserJet printer, your printer will operate at its optimum performance in this mode.

❖ **BR-Script 3 Mode**

BR-Script is an original page description language and is a PostScript language emulation interpreter. This printer supports level 3. This BR-Script interpreter enables full and satisfactory control of text and graphics on the pages.

Average users will not need extensive knowledge of the PostScript language. However, if you want to obtain technical information about PostScript commands, see the following commercial manuals:

- Adobe Systems Incorporated. PostScript Language Reference Manual, 2nd Edition. Menlo Park: Addison-Wesley Publishing Company, Inc., 1990.
- Adobe Systems Incorporated. PostScript Language Program Design. Menlo Park: Addison-Wesley Publishing Company, Inc., 1988.
- Adobe Systems Incorporated. PostScript Language Reference Manual. Menlo Park: Addison-Wesley Publishing Company, Inc., 1985.
- Adobe Systems Incorporated. PostScript Language Tutorial and Cookbook. Menlo Park: Addison-Wesley Publishing Company, Inc., 1985.
- Adobe Systems Incorporated. PostScript Language Reference Manual, third Edition. Addison-Wesley Longman, Inc., 1999.

❖ ***EPSON FX-850 and IBM Proprinter XL Modes***

The EPSON FX-850 and IBM Proprinter XL modes are the emulation modes this printer uses to emulate the industry-standard dot matrix printers of their respective manufacturer. Since most applications support these printers, you do not have to be concerned about compatibility.

Resident Fonts

66 Scalable and 12 Bitmapped Fonts

This printer has the following scalable fonts and bitmapped fonts. The fonts that can be used will vary according to the current emulation mode.

❖ HP LaserJet, EPSON FX-850 and IBM Proprinter XL Modes

◆ Scalable Fonts:

Intellifont compatible fonts:

- Alaska, Extrabold
- Antique Oakland, Oblique, Bold
- Brougham, Oblique, Bold, BoldOblique
- Cleveland Condensed
- Connecticut
- Guatemala Antique, Italic, Bold, BoldItalic
- Letter Gothic, Oblique, Bold
- Maryland
- Oklahoma, Oblique, Bold, BoldOblique
- PC Brussels Light, LightItalic, Demi, Demitalic
- PC Tennessee Roman, Italic, Bold, BoldItalic
- Utah, Oblique, Bold, BoldOblique
- Utah Condensed, Oblique, Bold, BoldOblique

◆ Microsoft Windows 95 TrueType™

Compatible fonts:

- BR Symbol
- Helsinki, Oblique, Bold, BoldOblique
- Tennessee Roman, Italic, Bold, BoldItalic
- W Dingbats

- ◆ ***Type 1 Font Compatible Fonts:***
 - Atlanta Book, BookOblique, Demi, DemiOblique
 - Calgary MediumItalic
 - Copenhagen Roman, Italic, Bold, BoldItalic
 - Portugal Roman, Italic, Bold, BoldItalic

- ◆ ***Original Fonts:***
 - Bermuda Script
 - Germany
 - San Diego
 - US Roman

- ◆ ***Bitmapped Fonts (Portrait and Landscape):***
 - LetterGothic16.66 Medium, Italic, Bold, BoldItalic
 - OCR-A
 - OCR-B

❖ BR-Script 3 Mode

Scalable Fonts:

- Atlanta Book, BookOblique, Demi, DemiOblique
- Alaska, Extrabold
- Antique Oakland, Oblique, Bold
- Bermuda Script
- BR Dingbats
- BR Symbol
- Brougham, Oblique, Bold, BoldOblique
- Brussels Light, LightItalic, Demi, Demitalic
- Calgary MediumItalic
- Cleveland Condensed
- Connecticut
- Copenhagen Roman, Italic, Bold, BoldItalic
- Germany
- Guatemala Antique, Italic, Bold, BoldItalic
- Helsinki, Oblique, Bold, BoldOblique
- Helsinki Narrow, Oblique, Bold, BoldOblique
- Letter Gothic, Oblique, Bold
- Maryland
- Oklahoma, Oblique, Bold, Bold Oblique
- Portugal Roman, Italic, Bold, BoldItalic
- San Diego
- Tennessee Roman, Italic, Bold, BoldItalic
- US Roman
- Utah, Oblique, Bold, BoldOblique
- Utah Condensed, Oblique, Bold, BoldOblique

Symbol Sets / Character Sets

OCR Symbol Sets

When the OCR-A or OCR-B font is selected, its corresponding symbol set is always used.

- OCR-A
- OCR-B

HP LaserJet Mode

• Note

Not all fonts support all symbol sets.

| | |
|-----------------------|------------------------------------|
| Roman 8 (8U) | ISO60 Norwegian1 (OD) |
| ISO Latin1 (0N) | ISO61 Norwegian2 (1D) |
| ISO Latin2 (2N) | ISO69 French (1F) |
| ISO Latin5 (5N) | ISO84 Portuguese (5S) |
| ISO Latin6 (6N) | ISO85 Spanish (6S) |
| PC-8 (10U) | HP German (OG) |
| PC-8 D/N (11U) | HP Spanish (1S) |
| PC-850 (12U) | ABICOMP Brazil / Portugal (13P) |
| PC-852 (17U) | ABICOMP International (14P) |
| PC-775 (26U) | PC-853 Latin3 (Turkish) (18U) |
| PC-1004 (9J) | PC-857 Latin5 (Turkish) (16U) |
| PC-8 Turkish (9T) | PC-858 Multilingual Euro (13U) |
| Windows Latin1 (19U) | PC-860 Portugal (20U) |
| Windows Latin2 (9E) | PC-861 Iceland (21U) |
| Windows Latin5 (5T) | PC-863 Canadian French (23U) |
| Windows Baltic (19L) | PC-865 Nordic (25U) |
| Legal (1U) | ISO8859 / 15 Latin 9 (9N) |
| Ventura Math (6M) | PC8 PC Nova (27Q) |
| Ventura Intl (13J) | Turkish8 (8T) |
| Ventura US (14J) | Roman9 (4U) |
| PS Math (5M) | Roman Extension (0E) |
| PS Text (10J) | ISO8859 / 7 Latin / Greek (12N) |
| Math-8 (8M) | Greek8 (8G) |
| Pi Font (15U) | Windows Greek (9G) |
| MS Publishing (6J) | PC-851 Greece (10G) |
| Windows 3.0 (9U) | PC8 Latin / Greek (12G) |
| Desktop (7J) | PC-869 Greece (11G) |
| MC Text (12J) | PC8 Greek Alternate (437G) (14G) |
| Symbol (19M) | Russian-GOST (12R) |
| Wingdings (579L) | Ukrainian (14R) |
| ISO2 IRV (2U) | ISO8859 / 5 Latin / Cyrillic (10N) |
| ISO4 UK (1E) | PC-855 Cyrillic (10R) |
| ISO6 ASCII (OU) | PC-866 Cyrillic (3R) |
| ISO10 Swedish (3S) | PC8 Bulgarian (13R) |
| ISO11 Swedish (OS) | Windows Cyrillic (9R) |
| ISO14 JIS ASCII (OK) | |
| ISO15 Italian (OI) | |
| ISO16 Portuguese (4S) | |
| ISO17 Spanish (2S) | |
| ISO21 German (1G) | |
| ISO25 French (OF) | |
| ISO57 Chinese (2K) | |

EPSON Mode

| | |
|--------------|---------------|
| US ASCII | Danish I |
| PC-8 | Italy |
| PC-8 D/N | Spanish |
| PC-850 | Swedish |
| PC-852 | Japanese |
| PC-860 | Norwegian |
| PC-863 | Danish II |
| PC-865 | UK ASCII II |
| PC-8 Turkish | French II |
| German | Dutch |
| UK ASCII I | South African |
| French I | |

IBM Mode

| | |
|----------|--------------|
| PC-8 | PC-860 |
| PC-8 D/N | PC-863 |
| PC-850 | PC-865 |
| PC-852 | PC-8 Turkish |

↔ Note

If you want to know the characters that are available in each symbol/character set, you can see them in the TABLE PRINT menu in PRINT MENU mode for each emulation. [For more information, see Chapter 3.](#)

◆ HP LaserJet 6P

Roman 8 (8U)

| | 0 | 1 | 2 | 3 | 4 | 5 | 6 | 7 | 8 | 9 | A | B | C | D | E | F |
|---|----|---|---|---|---|---|---|---|---|---|---|---|---|---|---|---|
| 0 | | | 0 | @ | P | ' | p | | | | À | Á | Â | Ã | Ä | Å |
| 1 | ! | 1 | A | Q | a | q | | | | | Ä | Å | Ë | Ì | Í | Î |
| 2 | " | 2 | B | R | b | r | | | | | Ë | Ì | Ó | Ô | Õ | Ö |
| 3 | # | 3 | C | S | c | s | | | | | Ë | Ì | Ô | Å | Ä | Å |
| 4 | \$ | 4 | D | T | d | t | | | | | Ë | Ì | Å | Ö | Ä | Å |
| 5 | % | 5 | E | U | e | u | | | | | Ë | Ì | Å | Ö | Ä | Å |
| 6 | & | 6 | F | V | f | v | | | | | Ë | Ì | Å | Ö | Ä | Å |
| 7 | ' | 7 | G | W | g | w | | | | | Ë | Ì | Å | Ö | Ä | Å |
| 8 | (| 8 | H | X | h | x | | | | | Ë | Ì | Å | Ö | Ä | Å |
| 9 |) | 9 | I | Y | i | y | | | | | Ë | Ì | Å | Ö | Ä | Å |
| A | * | : | J | Z | j | z | | | | | Ë | Ì | Å | Ö | Ä | Å |
| B | + | ; | K | [| k | { | | | | | Ë | Ì | Å | Ö | Ä | Å |
| C | , | < | L | \ | l | | | | | | Ë | Ì | Å | Ö | Ä | Å |
| D | - | = | M |] | m | } | | | | | Ë | Ì | Å | Ö | Ä | Å |
| E | . | > | N | ^ | n | ~ | | | | | Ë | Ì | Å | Ö | Ä | Å |
| F | / | ? | O | _ | o | ⌘ | | | | | Ë | Ì | Å | Ö | Ä | Å |

ISO Latin1 (0N)

| | 0 | 1 | 2 | 3 | 4 | 5 | 6 | 7 | 8 | 9 | A | B | C | D | E | F |
|---|----|---|---|---|---|---|---|---|---|---|---|---|---|---|---|---|
| 0 | | | 0 | @ | P | ' | p | | | | ° | À | Á | Â | Ã | Ä |
| 1 | ! | 1 | A | Q | a | q | | | | | ± | À | Á | Â | Ã | Ä |
| 2 | " | 2 | B | R | b | r | | | | | ± | À | Á | Â | Ã | Ä |
| 3 | # | 3 | C | S | c | s | | | | | ± | À | Á | Â | Ã | Ä |
| 4 | \$ | 4 | D | T | d | t | | | | | ± | À | Á | Â | Ã | Ä |
| 5 | % | 5 | E | U | e | u | | | | | ± | À | Á | Â | Ã | Ä |
| 6 | & | 6 | F | V | f | v | | | | | ± | À | Á | Â | Ã | Ä |
| 7 | ' | 7 | G | W | g | w | | | | | ± | À | Á | Â | Ã | Ä |
| 8 | (| 8 | H | X | h | x | | | | | ± | À | Á | Â | Ã | Ä |
| 9 |) | 9 | I | Y | i | y | | | | | ± | À | Á | Â | Ã | Ä |
| A | * | : | J | Z | j | z | | | | | ± | À | Á | Â | Ã | Ä |
| B | + | ; | K | [| k | { | | | | | ± | À | Á | Â | Ã | Ä |
| C | , | < | L | \ | l | | | | | | ± | À | Á | Â | Ã | Ä |
| D | - | = | M |] | m | } | | | | | ± | À | Á | Â | Ã | Ä |
| E | . | > | N | ^ | n | ~ | | | | | ± | À | Á | Â | Ã | Ä |
| F | / | ? | O | _ | o | ⌘ | | | | | ± | À | Á | Â | Ã | Ä |

Windows Latin1 (19U)

| | 0 | 1 | 2 | 3 | 4 | 5 | 6 | 7 | 8 | 9 | A | B | C | D | E | F |
|---|----|---|---|---|---|---|---|---|---|---|---|---|---|---|---|---|
| 0 | | | 0 | @ | P | ' | p | € | | | ° | À | Á | Â | Ã | Ä |
| 1 | ! | 1 | A | Q | a | q | | | | | ± | À | Á | Â | Ã | Ä |
| 2 | " | 2 | B | R | b | r | | | | | ± | À | Á | Â | Ã | Ä |
| 3 | # | 3 | C | S | c | s | | | | | ± | À | Á | Â | Ã | Ä |
| 4 | \$ | 4 | D | T | d | t | | | | | ± | À | Á | Â | Ã | Ä |
| 5 | % | 5 | E | U | e | u | | | | | ± | À | Á | Â | Ã | Ä |
| 6 | & | 6 | F | V | f | v | | | | | ± | À | Á | Â | Ã | Ä |
| 7 | ' | 7 | G | W | g | w | | | | | ± | À | Á | Â | Ã | Ä |
| 8 | (| 8 | H | X | h | x | | | | | ± | À | Á | Â | Ã | Ä |
| 9 |) | 9 | I | Y | i | y | | | | | ± | À | Á | Â | Ã | Ä |
| A | * | : | J | Z | j | z | | | | | ± | À | Á | Â | Ã | Ä |
| B | + | ; | K | [| k | { | | | | | ± | À | Á | Â | Ã | Ä |
| C | , | < | L | \ | l | | | | | | ± | À | Á | Â | Ã | Ä |
| D | - | = | M |] | m | } | | | | | ± | À | Á | Â | Ã | Ä |
| E | . | > | N | ^ | n | ~ | | | | | ± | À | Á | Â | Ã | Ä |
| F | / | ? | O | _ | o | ⌘ | | | | | ± | À | Á | Â | Ã | Ä |

Windows Latin2 (9E)

| | 0 | 1 | 2 | 3 | 4 | 5 | 6 | 7 | 8 | 9 | A | B | C | D | E | F |
|---|----|---|---|---|---|---|---|---|---|---|---|---|---|---|---|---|
| 0 | | | 0 | @ | P | ' | p | € | | | ° | À | Á | Â | Ã | Ä |
| 1 | ! | 1 | A | Q | a | q | | | | | ± | À | Á | Â | Ã | Ä |
| 2 | " | 2 | B | R | b | r | | | | | ± | À | Á | Â | Ã | Ä |
| 3 | # | 3 | C | S | c | s | | | | | ± | À | Á | Â | Ã | Ä |
| 4 | \$ | 4 | D | T | d | t | | | | | ± | À | Á | Â | Ã | Ä |
| 5 | % | 5 | E | U | e | u | | | | | ± | À | Á | Â | Ã | Ä |
| 6 | & | 6 | F | V | f | v | | | | | ± | À | Á | Â | Ã | Ä |
| 7 | ' | 7 | G | W | g | w | | | | | ± | À | Á | Â | Ã | Ä |
| 8 | (| 8 | H | X | h | x | | | | | ± | À | Á | Â | Ã | Ä |
| 9 |) | 9 | I | Y | i | y | | | | | ± | À | Á | Â | Ã | Ä |
| A | * | : | J | Z | j | z | | | | | ± | À | Á | Â | Ã | Ä |
| B | + | ; | K | [| k | { | | | | | ± | À | Á | Â | Ã | Ä |
| C | , | < | L | \ | l | | | | | | ± | À | Á | Â | Ã | Ä |
| D | - | = | M |] | m | } | | | | | ± | À | Á | Â | Ã | Ä |
| E | . | > | N | ^ | n | ~ | | | | | ± | À | Á | Â | Ã | Ä |
| F | / | ? | O | _ | o | ⌘ | | | | | ± | À | Á | Â | Ã | Ä |

The following table shows characters available only in the corresponding character set. The numbers at the top of the table are code values with which characters are to be replaced in the Roman 8 character set. For other characters, see the Roman 8 character set.

| SYMBOL SET | | 23 | 24 | 40 | 5B | 5C | 5D | 5E | 60 | 7B | 7C | 7D | 7E |
|------------------|----------|----|----|----|----|----|-----|----|----|----|----|----|----|
| ISO2 IRV | <ESC>(2U | # | ¤ | @ | [| \ |] | ^ | ' | { | | } | _ |
| ISO4 UK | <ESC>(1E | E | \$ | @ | [| \ |]] | ^ | ' | { | | } | _ |
| ISO6 ASCII | <ESC>(0U | # | \$ | @ | [| \ |]] | ^ | ' | { | | } | _ |
| ISO10 Swedish | <ESC>(3S | # | ¤ | @ | [| Ö | Å | Ä | ' | ä | ö | å | ü |
| ISO11 Swedish | <ESC>(0S | # | ¤ | Æ | Ä | Ö | Å | Ü | ' | ä | ö | å | ü |
| ISO14 JIS ASCII | <ESC>(0K | # | \$ | @ | [| ¥ |] | ^ | ' | { | | } | _ |
| ISO15 Italian | <ESC>(0I | E | \$ | Š | ° | Ç | È | ^ | ' | à | ó | è | ì |
| ISO16 Portuguese | <ESC>(4S | # | \$ | Š | À | Ç | Ó | ^ | ' | ã | ç | õ | ó |
| ISO17 Spanish | <ESC>(2S | E | \$ | Š | ¡ | Ñ | Ú | ^ | ' | á | ñ | ú | í |
| ISO21 German | <ESC>(1G | # | \$ | Š | À | Ö | Ü | ^ | ' | ä | ö | ü | ß |
| ISO25 French | <ESC>(0F | E | \$ | š | ° | Ç | Š | ^ | ' | é | ù | é | í |
| ISO57 Chinese | <ESC>(2K | # | ¥ | @ | [| \ |]] | ^ | ' | { | | } | _ |
| ISO60 Norwegian1 | <ESC>(0D | # | \$ | @ | Æ | Ø | Å | ^ | ' | æ | ø | å | — |
| ISO61 Norwegian2 | <ESC>(1D | Š | \$ | @ | Æ | Ø | Å | ^ | ' | æ | ø | å | — |
| ISO69 French | <ESC>(1F | E | \$ | š | ° | Ç | Š | ^ | ' | é | ù | é | í |
| ISO84 Portuguese | <ESC>(5S | # | \$ | ' | À | Ç | Ó | ^ | ' | ã | ç | õ | ó |
| ISO85 Spanish | <ESC>(6S | # | \$ | ' | ¡ | Ñ | Ú | ^ | ' | á | ñ | ú | í |
| HP German | <ESC>(0G | E | \$ | Š | À | Ö | Ü | ^ | ' | ä | ö | ü | ß |
| HP Spanish | <ESC>(1S | # | \$ | @ | ¡ | Ñ | Ú | ^ | ' | { | ñ | } | í |

◆ **HP LaserJet IIP/6P, EPSON FX-850, IBM Proprinter XL**

PC-8

| | 0 | 1 | 2 | 3 | 4 | 5 | 6 | 7 | 8 | 9 | A | B | C | D | E | F |
|---|---|----|----|---|---|---|---|---|---|---|---|---|---|---|---|---|
| 0 | ▶ | 0 | @ | P | ` | p | Ç | É | á | ⌘ | ⌘ | α | ≡ | | | |
| 1 | ⊙ | ◀ | ! | 1 | A | Q | a | q | ü | æ | í | ⌘ | ⌘ | β | ± | |
| 2 | ⊙ | ‡ | " | 2 | B | R | b | r | é | Æ | ó | ⌘ | ⌘ | Γ | ≥ | |
| 3 | ♥ | !! | # | 3 | C | S | s | s | â | ô | ú | ⌘ | ⌘ | π | ≤ | |
| 4 | ♦ | ¶ | \$ | 4 | D | T | d | t | ä | ö | ñ | ⌘ | ⌘ | Σ | ∫ | |
| 5 | ♣ | § | % | 5 | E | U | e | u | â | ò | Ñ | ⌘ | ⌘ | σ | ∫ | |
| 6 | ♠ | - | & | 6 | F | V | f | v | â | û | ë | ⌘ | ⌘ | μ | ÷ | |
| 7 | • | ‡ | ' | 7 | G | W | g | w | ç | ù | ë | ⌘ | ⌘ | τ | ≈ | |
| 8 | ■ | ↑ | (| 8 | H | X | h | x | ê | ÿ | ç | ⌘ | ⌘ | φ | ° | |
| 9 | ○ | ↓ |) | 9 | I | Y | i | y | ë | Ö | ⌘ | ⌘ | ⌘ | ⊙ | · | |
| A | ⊗ | → | * | : | J | Z | j | z | è | Ü | ⌘ | ⌘ | ⌘ | Ω | · | |
| B | ♂ | ← | + | ; | K | [| k | { | ï | ½ | ⌘ | ⌘ | ⌘ | δ | √ | |
| C | ♀ | ⌊ | , | < | L | \ | l | | î | ¼ | ⌘ | ⌘ | ⌘ | ∞ | n | |
| D | ♯ | ↔ | - | = | M |] | m | } | ï | Ø | ⌘ | ⌘ | ⌘ | φ | ² | |
| E | ♯ | ▲ | . | > | N | ^ | n | ~ | Ä | x | ⌘ | ⌘ | ⌘ | e | ■ | |
| F | * | ▼ | / | ? | O | _ | o | ◊ | Å | f | ⌘ | ⌘ | ⌘ | ○ | | |

PC-850

| | 0 | 1 | 2 | 3 | 4 | 5 | 6 | 7 | 8 | 9 | A | B | C | D | E | F |
|---|---|----|----|---|---|---|---|---|---|---|---|---|---|---|---|---|
| 0 | ▶ | 0 | @ | P | ` | p | Ç | É | á | ⌘ | ⌘ | α | ≡ | | | |
| 1 | ⊙ | ◀ | ! | 1 | A | Q | a | q | ü | æ | í | ⌘ | ⌘ | β | ± | |
| 2 | ⊙ | ‡ | " | 2 | B | R | b | r | é | Æ | ó | ⌘ | ⌘ | Γ | ≥ | |
| 3 | ♥ | !! | # | 3 | C | S | s | s | â | ô | ú | ⌘ | ⌘ | π | ≤ | |
| 4 | ♦ | ¶ | \$ | 4 | D | T | d | t | ä | ö | ñ | ⌘ | ⌘ | Σ | ∫ | |
| 5 | ♣ | § | % | 5 | E | U | e | u | â | ò | Ñ | ⌘ | ⌘ | σ | ∫ | |
| 6 | ♠ | - | & | 6 | F | V | f | v | â | û | ë | ⌘ | ⌘ | μ | ÷ | |
| 7 | • | ‡ | ' | 7 | G | W | g | w | ç | ù | ë | ⌘ | ⌘ | τ | ≈ | |
| 8 | ■ | ↑ | (| 8 | H | X | h | x | ê | ÿ | ç | ⌘ | ⌘ | φ | ° | |
| 9 | ○ | ↓ |) | 9 | I | Y | i | y | ë | Ö | ⌘ | ⌘ | ⌘ | ⊙ | · | |
| A | ⊗ | → | * | : | J | Z | j | z | è | Ü | ⌘ | ⌘ | ⌘ | Ω | · | |
| B | ♂ | ← | + | ; | K | [| k | { | ï | ½ | ⌘ | ⌘ | ⌘ | δ | √ | |
| C | ♀ | ⌊ | , | < | L | \ | l | | î | ¼ | ⌘ | ⌘ | ⌘ | ∞ | n | |
| D | ♯ | ↔ | - | = | M |] | m | } | ï | Ø | ⌘ | ⌘ | ⌘ | φ | ² | |
| E | ♯ | ▲ | . | > | N | ^ | n | ~ | Ä | x | ⌘ | ⌘ | ⌘ | e | ■ | |
| F | * | ▼ | / | ? | O | _ | o | ◊ | Å | f | ⌘ | ⌘ | ⌘ | ○ | | |

◆ **EPSON FX-850**

US ASCII

| | 0 | 1 | 2 | 3 | 4 | 5 | 6 | 7 | 8 | 9 | A | B | C | D | E | F |
|---|---|---|----|---|---|---|---|---|---|----|---|---|---|---|---|---|
| 0 | | | | | 0 | @ | P | ` | p | | 0 | @ | P | ` | p | |
| 1 | | | ! | 1 | A | Q | a | q | | ! | 1 | A | Q | a | q | |
| 2 | | | " | 2 | B | R | b | r | | " | 2 | B | R | b | r | |
| 3 | | | # | 3 | C | S | s | s | | # | 3 | C | S | s | s | |
| 4 | | | \$ | 4 | D | T | d | t | | \$ | 4 | D | T | d | t | |
| 5 | | | % | 5 | E | U | e | u | | % | 5 | E | U | e | u | |
| 6 | | | & | 6 | F | V | f | v | | & | 6 | F | V | f | v | |
| 7 | | | ' | 7 | G | W | g | w | | ' | 7 | G | W | g | w | |
| 8 | | | (| 8 | H | X | h | x | | (| 8 | H | X | h | x | |
| 9 | | |) | 9 | I | Y | i | y | |) | 9 | I | Y | i | y | |
| A | | | * | : | J | Z | j | z | | * | : | J | Z | j | z | |
| B | | | + | ; | K | [| k | { | | + | ; | K | [| k | { | |
| C | | | , | < | L | \ | l | | | , | < | L | \ | l | | |
| D | | | - | = | M |] | m | } | | - | = | M |] | m | } | |
| E | | | . | > | N | ^ | n | ~ | | . | > | N | ^ | n | ~ | |
| F | | | / | ? | O | _ | o | | | / | ? | O | _ | o | | |

The following table shows characters available only in the corresponding character set. The numbers at the top of the table are code values with which characters are to be replaced in the US ASCII character set. For other characters, see the US ASCII character set.

| SYMBOL SET | 23 | 24 | 40 | 5B | 5C | 5D | 5E | 60 | 7B | 7C | 7D | 7E |
|---------------|----|----|----|----|----|----|----|----|----|----|----|----|
| German | # | \$ | § | Ä | Ö | Ü | ^ | ˘ | ä | ö | ü | ß |
| UK ASCII I | £ | \$ | @ | | \ | l | ^ | ˘ | { | | } | ˘ |
| French I | # | \$ | @ | ° | ç | ç | ^ | ˘ | { | ù | è | ˘ |
| Danish I | # | \$ | @ | Æ | Ø | Å | ^ | ˘ | { | ø | æ | ˘ |
| Italy | # | \$ | @ | ° | \ | é | ^ | ˘ | à | ò | è | ì |
| Spanish | ¢ | \$ | @ | ¡ | Ñ | ç | ^ | ˘ | ñ | õ | õ | ˘ |
| Swedish | # | ¤ | É | Å | Ö | Ä | ^ | ˘ | ä | ö | å | ü |
| Japanese | # | \$ | @ | [| ¥ |] | ^ | ˘ | { | | } | ˘ |
| Norwegian | # | ¤ | É | Æ | Ø | Å | ^ | ˘ | { | ø | å | ü |
| Danish II | # | \$ | É | Æ | Ø | Å | ^ | ˘ | { | ø | å | ü |
| UK ASCII II | # | £ | @ | [| \ | l | ^ | ˘ | { | | } | ˘ |
| French II | # | â | à | î | ç | ê | ^ | ˘ | é | ú | è | ï |
| Dutch | # | \$ | @ | l | l | f | ^ | ˘ | é | ij | è | ˘ |
| South African | # | ê | É | Ê | Ö | è | ^ | ˘ | é | ö | ô | ü |

Trademarks

The Brother logo is a registered trademark of Brother Industries, Ltd.

Apple, the Apple Logo, and Macintosh are registered trademarks in the United States and other countries, and TrueType is a trademark of Apple Computer, Inc.

Apple Macintosh, iMac, LaserWriter, and AppleTalk are trademarks of Apple Computer, Inc.

Epson is a registered trademark and FX-80 and FX-850 are trademarks of Seiko Epson Corporation.

Hewlett Packard is a registered trademark and HP LaserJet 6P, 6L, 5P, 5L, 4, 4L 4P, III, IIIP, II, and IIP are trademarks of Hewlett-Packard Company.

IBM, IBM PC, and Proprinter are registered trademarks of International Business Machines Corporation.

Microsoft and MS-DOS are registered trademarks of Microsoft Corporation. Windows is a registered trademark of Microsoft Corporation in the U.S. and other countries.

ENERGY STAR is a U.S. registered mark.

All other brand and product names mentioned in this User's Guide are registered

◆ **Compilation and Publication Notice**

This guide has been published under the supervision of Brother Industries Ltd., It covers the latest product's descriptions and specifications.

The contents of this guide and the specifications of this product may change without notice.

We reserve the right to change without giving notice the specifications and materials mentioned in this guide. We will not be responsible for any damages (that are) caused by you relying on the information given in this guide.

©2002 Brother Industries Ltd.

Regulations

Federal Communications Commission (FCC) Declaration of Conformity (For USA Only)

Responsible Party: Brother International Corporation
100 Somerset Corporate Boulevard
Bridgewater, NJ 08807-0911, USA
TEL : (908) 704-1700

declares, that the products

Product Name : Brother Laser Printer HL-1850, HL-1870N

Model Numbers : HL-18

Product Options : ALL

complies with Part 15 of the FCC Rules. Operation is subject to the following two conditions: (1) This device may not cause harmful interference, and (2) this device must accept any interference received, including interference that may cause undesired operation.

This equipment has been tested and found to comply with the limits for a Class B digital device, pursuant to Part 15 of the FCC Rules. These limits are designed to provide reasonable protection against harmful interference in a residential installation. This equipment generates, uses, and can radiate radio frequency energy and, if not installed and used in accordance with the instructions, may cause harmful interference to radio communications. However, there is no guarantee that interference will not occur in a particular installation. If this equipment does cause harmful interference to radio or television reception, which can be determined by turning the equipment off and on, the user is encouraged to try to correct the interference by one or more of the following measures:

- Reorient or relocate the receiving antenna.
- Increase the separation between the equipment and receiver.
- Connect the equipment into an outlet on a circuit different from that to which the receiver is connected.
- Consult the dealer or an experienced radio/TV technician for help.

Important

A shielded interface cable should be used in order to ensure compliance with the limits for a Class B digital device.

Changes or modifications not expressly approved by Brother Industries, Ltd. could void the user's authority to operate the equipment.

Industry Canada Compliance Statement (For Canada Only)

This Class B digital apparatus complies with Canadian ICES-003.

Cet appareil numérique de la classe B est conforme à la norme NMB-003 du Canada.

International ENERGY STAR Compliance Statement

The purpose of the International ENERGY STAR Program is to promote the development and popularization of energy-efficient office equipments.

As an ENERGY STAR Partner, Brother Industries, Ltd. has determined that this product meets the ENERGY STAR guidelines for energy efficiency.

**Laser Safety (For 100–120 V Model Only)**

This printer is certified as a Class I laser product under the U.S. Department of Health and Human Services (DHHS) Radiation Performance Standard according to the Radiation Control for Health and Safety Act of 1968. This means that the printer does not produce hazardous laser radiation.

Since radiation emitted inside the printer is completely confined within protective housings and external covers, the laser beam cannot escape from the machine during any phase of user operation.

FDA Regulations (For 100-120 V Model Only)

U.S. Food and Drug Administration (FDA) has implemented regulations for laser products manufactured on and after August 2, 1976. Compliance is mandatory for products marketed in the United States. One of the following labels on the back of the printer indicates compliance with the FDA regulations and must be attached to laser products marketed in the United States.

MANUFACTURED:

Brother Corporation (Asia) Ltd. Brother Buji Nan Ling Factory
Gold Garden Ind., Nan Ling Village, Buji, Rong Gang, Shenzhen, CHINA
This product complies with FDA radiation performance standards, 21 CFR
Subchapter J

MANUFACTURED:

BROTHER INDUSTRIES LTD.
15-1 Naeshiro-cho Mizuho-ku Nagoya, 467-8561 Japan
This product complies with FDA radiation performance standards, 21 CFR
Subchapter J

Caution

Use of controls, adjustments or performance of procedures other than those specified in this manual may result in hazardous radiation exposure.

IEC 60825 Specification (For 220–240 V Model Only)

This printer is a Class 1 laser product as defined in IEC 60825 specifications. The label shown below is attached in countries where it is required.

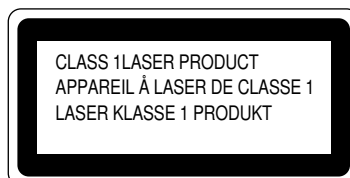

This printer has a Class 3B Laser Diode that emits invisible laser radiation in the Scanner Unit. The Scanner Unit should not be opened under any circumstances.

Caution

Use of controls, adjustments or performance of procedures other than those specified in this manual may result in hazardous radiation exposure.

Internal Laser Radiation

| | |
|----------------------|---|
| Max. Radiation Power | 5mW |
| Wave Length | 760 – 810 nm |
| Laser Class | Class IIIb (Accordance with 21 CFR Part 1040.10) Class 3B (Accordance with IEC60825) |

(For Finland and Sweden)
LUOKAN 1 LASERLAITE
KLASS 1 LASER APPARAT

Varoitus! Laitteen käyttäminen muulla kuin tässä käyttöohjeessa mainitulla tavalla saattaa altistaa käyttäjän turvallisuusluokan 1 ylittävälle näkymättömälle lasersäteilylle.

Varning – Om apparaten används på annat sätt än i denna Bruksanvisning specificerats, kan användaren utsättas för osynlig laserstrålning, som överskrider gränsen för laserklass 1.

Radio Interference (220-240 V Model Only)

This printer complies with EN55022(CISPR Publication 22)/Class B.

Before this product is used, ensure that you use a double-shielded interface cable with twisted-pair conductors and that it is marked "IEEE 1284-compliant." We recommend to use a parallel cable that is 2.0 meters (6 1/2 feet) or less.

IMPORTANT - For Your Safety

To ensure safe operation the three-pin electrical plug supplied must be inserted only into a standard three-pin power point that is properly grounded through normal household wiring.

Extension cords used with the equipment must be three-pin plug type and correctly wired to provide proper grounding. Incorrectly wired extension cords may cause personal injury and equipment damage.

The fact that the equipment operates satisfactorily does not imply that the power is grounded and that the installation is completely safe. For your safety, if in any doubt about the effective grounding of the power, consult a qualified electrician.

Disconnect Device

This printer must be installed near a power outlet that is easily accessible. In case of emergencies, you must disconnect the power cord from the power outlet in order to shut off power completely.

LAN Connection

Caution

Connect this product to a LAN connection that is not subjected to over voltages.

Geräuschemission / Acoustic Noise Emission (For Germany Only)

Lpa < 70 dB (A) DIN 45635-19-01-KL2

IT power system (For Norway Only)

This product is also designed for IT power system with phase to phase voltage 230 V.

IMPORTANT - Wiring Information (For U.K. Only)

If the power cord supplied with this printer is not suitable for your electrical outlet, remove the plug from the mains cord and fit an appropriate three-pin plug. If the replacement plug is intended to take a fuse then fit a fuse with the same rating as the original.

If a moulded plug is severed from the power cord then it should be destroyed because a plug with cut wires is dangerous if plugged into a live socket outlet. Do not leave it where a child might find it.

In the event of replacing the plug fuse, fit a fuse approved by ASTA to BS1362 with the same rating as the original fuse.

Always replace the fuse cover. Never use a plug with the cover omitted.

WARNING - THIS PRINTER MUST BE PROPERLY EARTHED.

The wires in the mains cord are coloured in accordance with the following code:

| | |
|-------------------|---------|
| Green and yellow: | Ground |
| Blue: | Neutral |
| Brown: | Live |

The colours of the wiring in the power lead of this printer may not correspond with the markings which identify the terminals in your plug. If you need to fit a different plug, proceed as follows.

Remove a length of the cord outer sheath, taking care not to damage the coloured insulation of the wires inside.

Cut each of the three wires to the appropriate length. If the construction of the plug permits, leave the green and yellow wire longer than the others so that, in the event that the cord is pulled out of the plug, the green and yellow wire will be the last to disconnect.

Remove a short section of the coloured insulation to expose the wires.

The wire which is coloured green and yellow must be connected to the terminal in the plug which is marked with the letter "E" or by the earth symbol or coloured green or green and yellow.

The wire which is coloured blue must be connected to the terminal which is marked with the letter "N" or coloured black or blue.

The wire which is coloured brown must be connected to the terminal which is marked with the letter "L" or coloured red or brown.

The outer sheath of the cord must be secured inside the plug. The coloured wires should not hang out of the plug.

“EC” Declaration of ConformityManufacture

Brother Industries Ltd.,
15-1, Naeshiro-cho, Mizuho-ku,
Nagoya 467-8561, Japan

Plant

Brother Corporation (Asia) Ltd.,
Brother Buji Nan Ling Factory,
Gold Garden Ind., Nan Ling Village,
Buji Rong Gang Shenzhen, China

Plant

Brother Industries Ltd.,
Kariya Plant,
1-5, Kitajizoyama, Noda-cho,
Kariya-shi, Aichi-ken 448-0803 Japan

Herewith declare that:

Products description: Laser Printer
Product Name: HL-1850, HL-1870N
Model Number: HL-18

are in conformity with provisions of the Directives applied : Low Voltage Directive 73/23/EEC (as amended by 93/68/EEC) and the Electromagnetic Compatibility Directive 89/336/EEC (as amended by 91/263/EEC and 92/31/EEC and 93/68/EEC).

Standards applied:

Harmonized:

Safety : EN60950:1992 + A1:1993 + A2:1993 + A3:1995 + A4:1997 + A11:1997

EMC : EN55022:1998 Class B
EN55024:1998
EN61000-3-2:1995 + A1:1998 + A2:1998
EN61000-3-3:1995

Year in which CE marking was First affixed : 2001

Issued by : Brother Industries, Ltd.

Date : 29 October 2001

Place : Nagoya, Japan

Signature :

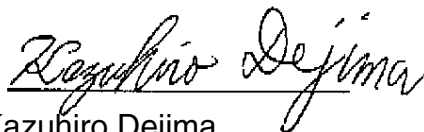

Kazuhiro Dejima
Manager
Quality Audit Group
Quality Management Dept.
Information & Document Company

INDEX

-

- key 3-11
- button 3-11

+

- + button 3-11

A

- AC power cord 1-1
- AC power inlet 1-4
- accessory 5-2
- Apple LaserWriter 2-19
- automatic emulation selection 2-20
- automatic interface selection 2-21

B

- back light 3-14
- Back button 3-12
- bitmapped font A-13
- booklet 1-27
- BRAdmin professional 2-17
- BR-Script 3 2-1
- BR-Script 3 mode 3-30, A-11

C

- character sets A-16
- components 1-1
- consumables 5-1
- control panel 3-1
- corona wire 5-17

D

- data lamp 3-13
- Device Options 2-6
- drum unit 5-2, 5-11
- drum unit assembly 1-1
- duplex 2-4
- duplex printing 1-30
- duplex tray 1-4

E

- emulation mode 3-30, A-11
- envelopes 1-22
- environment 1-6
- EPSON FX-850 3-24
- EPSON FX-850 mode 3-31, A-12
- error messages 6-1
- extension flap 1-3

F

- face up output tray 1-4
- face up printing 1-20
- face up tray extension 1-4
- factory reset 3-28
- factory setting 2-22, 3-31
- fixing unit 5-19
- front cover 1-3

G

- Go button 3-3

H

- HP LaserJet mode 3-30, A-11

HQ1200 2-4, A-4

I

IBM PROPRINTER..... 3-25

IBM Proprinter XL mode..... 3-31, A-12

information mode..... 3-19

interface cover 1-4

interface mode..... 3-27

IP address 3-29

J

Job Cancel button..... 3-4

L

labels 1-27

LCD 3-14, 6-1

LCD display 3-14

LED..... 3-13

lower tray unit 4-2

LT-500 4-2

M

Macintosh 2-19

maintenance message 6-3

manual feed..... 1-36

memory 4-10

Menu button..... 3-11

Multi-purpose tray..... 1-17

N

Network board 4-5

network mode..... 3-26

O

options 4-1

P

panel setting..... 3-18

paper mode..... 3-32

paper adjustment lever for duplex printing..... 1-4

paper cassette 1-1, 1-3, 1-14

paper feeding kit 5-19

paper jam 6-6

parallel cable..... 1-2

parallel interface connector..... 1-4

PCB access plate..... 1-4

PCL6 2-1

power supply 1-5

power switch 1-4

PPD..... 2-19

primary corona wire 5-17

print media 1-7, 1-9, A-5

print menu 3-33

print menu mode..... 3-22

print quality..... 2-4

printable area 1-13

printer driver..... 2-1

printer status message 3-15

Q

quality mode..... 3-32

R

RAM 4-9

replace fuser 5-19

replace laser 5-19

replace pf kit1..... 5-19

replace pf kit2..... 5-19

reprint..... 2-7, 3-5

| | |
|-----------------------|------|
| Reprint button | 3-5 |
| reset menu mode | 3-28 |
| reset printer | 3-28 |

S

| | |
|----------------------------|------|
| scalable font | A-13 |
| scanner unit | 5-19 |
| scanner window | 5-16 |
| secure data | 3-8 |
| service call message | 6-4 |
| Set button | 3-12 |
| setup mode | 3-21 |
| Storage Manager | 2-17 |
| switch | 3-2 |
| symbol set | A-16 |

T

| | |
|-----------------------|----------|
| TCP/IP | 3-26 |
| toner cartridge | 5-2, 5-3 |
| TONER LOW | 5-4 |
| transparencies | 1-27 |

U

| | |
|---------------------|-----|
| USB connector | 1-4 |
|---------------------|-----|

W

| | |
|-----------------|-----|
| watermark | 2-5 |
|-----------------|-----|