



Brother Laser Printer

A grayscale line drawing of a Brother HL-2700CN series laser printer, shown from a three-quarter perspective. The printer has a control panel on the left side and a paper tray on the right.

HL-2700CN series

User's Guide

For visually-impaired users

You can read this manual with Screen Reader 'text-to-speech' software.

You must set up the hardware and install the driver before you can use the printer.

Please use the *Quick Setup Guide* to set up the printer. You can find a printed copy in the box or view it on the CD-ROM we have supplied.

Please read this *User's Guide* thoroughly before you use the printer. Keep the CD-ROM in a convenient place so you can use it quickly if you need to.

Please visit our web site at <http://solutions.brother.com> where you can get answers to Frequently Asked Questions (FAQs), Product Support and Technical Questions, and the latest Driver Updates and Utilities.

Definitions of warnings, cautions, and notes

We use the following terms throughout this User's Guide:



You must follow these warnings to prevent possible personal injury.



You must follow these instructions to make sure you use the printer properly and do not damage it.



Remember these useful tips when you use the printer.

To use the printer safely

- ⚠ The fusing unit becomes extremely hot during operation. Wait until it has cooled down sufficiently before replacing consumable items.

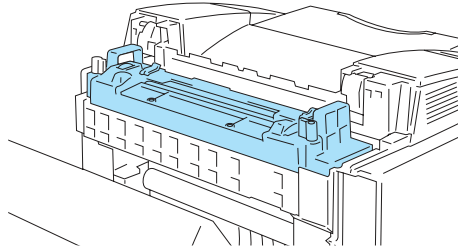

The fusing unit is marked with the caution label. Please do NOT take off or damage the label.

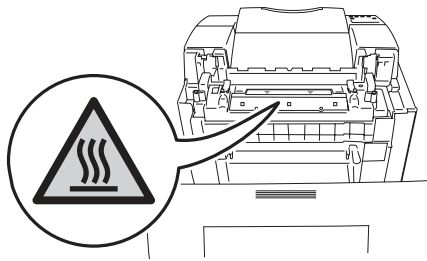



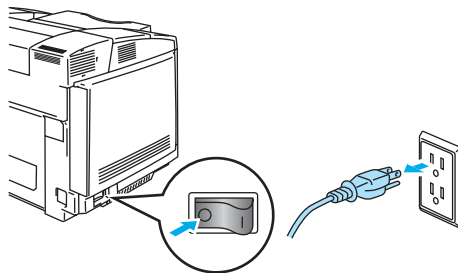

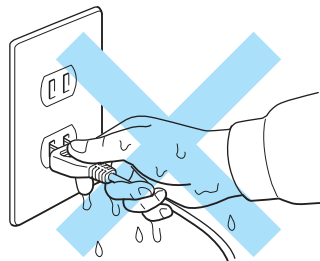

- ⚠ There are high voltage electrodes inside the printer. Before you clean the printer, clear a paper jam or replace parts, make sure you have turned off the power switch and unplugged the printer from the AC power outlet/socket.



- ⚠ Do not handle the plug with wet hands - this constitutes an electric shock hazard.



- ⚠ This printer is heavy and weighs approximately 31.5 kg (69.4 lb). When you move or lift this printer, make sure at least two people lift it together. Be careful not to trap your fingers when you set the machine back down.

-  If the printer becomes hot, blows smoke, or generates obscure odor, immediately turn off the power switch and unplug the printer from the AC power outlet/socket. Call your dealer or Brother Customer Service.
-  If metal objects, water or other liquids get inside the printer, immediately turn off the power switch and unplug the printer from the AC power outlet/socket. Call your dealer or Brother Customer Service.
-  Do not put consumable items such as the toner cartridges and the waste toner pack into a fire. Some consumable items can be flammable under certain conditions.
-  Do not look directly at the laser beam light. It might cause damage to your eyesight. Do not remove or break open the printer's safety interlocks.
-  Do not run the printer with the top cover, front cover and back covers open and the interlocks removed.
-  Do not place any items on the printer.

Printer do's and don'ts for optimum print quality

- ❗ Before you move or lift the printer, remove the toner cartridges, waste toner pack and fusing unit to avoid spills. Be sure to keep the printer as level as possible. Damage caused by failure to remove the supplies may void your warranty.
- ❗ Do not touch the rollers of the fusing unit. This can degrade print quality.

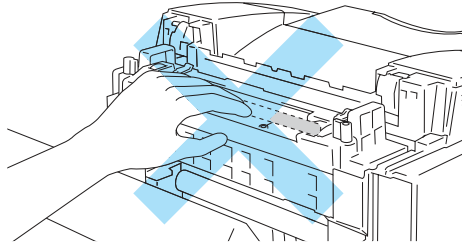

IMPORTANT: For technical and operational help, you must call the country where you bought the printer. Calls must be made *from within* that country.

Register your product

By registering your product with Brother International Corporation, you will be recorded as the original owner of the product.

Your registration with Brother:

- may serve as a confirmation of the purchase date of your product should you lose your receipt;
- may support an insurance claim by you in the event of product loss covered by insurance; and,
- will help us notify you of enhancements to your product and special offers.

Please complete the Brother Warranty Registration or, for your convenience and most efficient way to register your new product, register on-line at

<http://www.brother.com/registration/>

Frequently asked questions (FAQs)

The Brother Solutions Center is our one-stop resource for all your Printer needs. You can download the latest software and utilities, read FAQs and troubleshooting tips, and go to the 'Solutions' section to learn how to get the most from your Brother product.

<http://solutions.brother.com>

You can check here for the Brother driver updates.

Customer Service

In USA: 1-877-284-3238

In Canada: 1-877-BROTHER

In Europe: Visit www.brother.com for contact information on your local Brother office.

If you have comments or suggestions, please write us at:

In USA: Printer Customer Support
Brother International Corporation
15 Musick
Irvine, CA 92618

In Canada: Brother International Corporation (Canada), Ltd.
- Marketing Dept.
1, rue Hotel de Ville
Dollard-des-Ormeaux, PQ, Canada H9B 3H6

Service center locator (USA only)

For the location of a Brother authorized service center, call 1-800-284-4357.

Service center locations (Canada only)

For the location of a Brother authorized service center, call 1-877-BROTHER

Service center locations (Europe)

For service centres in Europe, contact your local Brother Office. Address and telephone contact information for European offices can be found at www.brother.com and selecting your country from the pull down list.

Brother fax back system (USA only)

Brother has installed an easy to use fax back system so you can get instant answers to common technical questions and product information. This is available 24 hours a day, 7 days a week. You can use the system to send the information to any fax machine.

Call the number below and follow the recorded instructions to receive a fax about how to use the system and an index of fax back subjects.

In USA only: 1-800-521-2846

Internet Addresses

Brother Global Web Site: <http://www.brother.com>

For Frequently Asked Questions (FAQs), Product Support and Technical Questions, and Driver Updates and Utilities: <http://solutions.brother.com>

(In USA Only) For Brother Accessories & Supplies: <http://www.brothermall.com>

Important information: Regulations

Federal Communications Commission (FCC) Declaration of Conformity (For USA)

Responsible Party: Brother International Corporation
100 Somerset Corporate Boulevard
P.O. Box 6911
Bridgewater, NJ 08807-0911
USA
Telephone: (908) 704-1700

declares, that the products

Product name: Laser Printer HL-2700CN
Model number: HL-2700CN
Product options: All

complies with Part 15 of the FCC Rules. Operation is subject to the following two conditions: (1) This device may not cause harmful interference, and (2) this device must accept any interference received, including interference that may cause undesired operation.

This equipment has been tested and found to comply with the limits for a Class B digital device, pursuant to Part 15 of the FCC Rules. These limits are designed to provide reasonable protection against harmful interference in a residential installation. This equipment generates, uses, and can radiate radio frequency energy and, if not installed and used in accordance with the instructions, may cause harmful interference to radio communications. However, there is no guarantee that interference will not occur in a particular installation. If this equipment does cause harmful interference to radio or television reception, which can be determined by turning the equipment off and on, the user is encouraged to try to correct the interference by one or more of the following measures:

- Reorient or relocate the receiving antenna.
- Increase the separation between the equipment and receiver.
- Connect the equipment into an outlet on a circuit different from that to which the receiver is connected.
- Call the dealer, Brother Customer Service, or an experienced radio/TV technician for help.

Important

A shielded interface cable should be used to ensure compliance with the limits for a Class B digital device.

Changes or modifications not expressly approved by Brother Industries, Ltd. could void the user's authority to operate the equipment.

Industry Canada Compliance Statement (For Canada)

This Class B digital apparatus complies with Canadian ICES-003.

Cet appareil numérique de la classe B est conforme à la norme NMB-003 du Canada.

Radio interference (220 to 240 volt model only)

This printer follows EN55022 (CISPR Publication 22)/Class B.

Before you use this product, make sure that you use a double-shielded interface cable with twisted-pair conductors and that it is marked "IEEE1284 compliant". The cable must not be more than 2 metres long.

International ENERGY STAR® Compliance Statement

The purpose of the International ENERGY STAR® Program is to promote the development and popularization of energy-efficient office equipment.

As an ENERGY STAR® Partner, Brother Industries, Ltd. has determined that this product meets the ENERGY STAR® guidelines for energy efficiency.

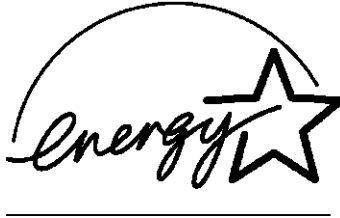

Laser Safety (100 to 120 volt model only)

This printer is certified as a Class I laser product under the U.S. Department of Health and Human Services (DHHS) Radiation Performance Standard according to the Radiation Control for Health and Safety Act of 1968. This means that the printer does not produce hazardous laser radiation.

Since radiation emitted inside the printer is completely confined within protective housings and external covers, the laser beam cannot escape from the machine during any phase of user operation.

FDA Regulations (100 to 120 volt model only)

U.S. Food and Drug Administration (FDA) has implemented regulations for laser products manufactured on and after August 2, 1976. Compliance is mandatory for products marketed in the United States. One of the following labels on the back of the printer indicates compliance with the FDA regulations and must be attached to laser products marketed in the United States.

<p>MANUFACTURED: Brother Industries, Ltd., 15-1 Naeshiro-cho Mizuho-ku Nagoya, 467-8561 Japan This product complies with FDA radiation performance standards, 21 CFR subchapter J.</p>
--

Caution: Use of controls, adjustments or performance of procedures other than those specified this User's Guide may result in hazardous radiation exposure.

IEC 60825 specification (220 to 240 volt model only)

This printer is a Class 1 laser product as defined in IEC 60825 specifications. The label shown below is attached in countries where it is needed.



This printer has a Class 3B laser diode which produces invisible laser radiation in the scanner unit. You should not open the scanner unit under any circumstances.

Caution: Use of controls or adjustments or performance of procedures other than those specified in this User's Guide may result in hazardous radiation exposure.

The following caution label is attached on the cover of the scanner unit.

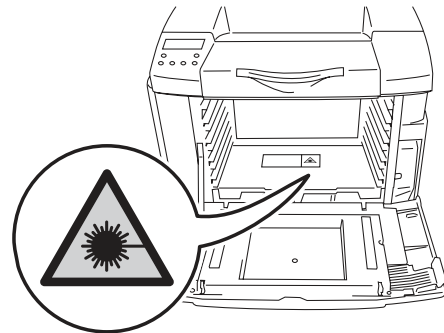

For Finland and Sweden
LUOKAN 1 LASERLAITE
KLASS 1 LASER APPARAT

Varoitus! Laitteen käyttäminen muulla kuin tässä käyttöohjeessa mainitulla tavalla saattaa altistaa käyttäjän turvallisuusluokan 1 ylittävälle näkymättömälle lasersäteilylle.

Varning Om apparaten används på annat sätt än i denna Bruksanvisning specificerats, kan användaren utsättas för osynlig laserstrålning, som överskrider gränsen för laserklass 1.

Internal laser radiation

Maximum radiation power: 5 mW
Wave length: 780 - 800 nm
Laser class: Class IIIb (Accordance with 21 CFR Part 1040.10)
Class 3B (Accordance with IEC 60825)

IMPORTANT - For Your Safety

To ensure safe operation the supplied three-pin plug must be inserted only into a standard three-pin power outlet that is properly grounded through the standard electrical wiring.

Extension cords used with this printer must be three-pin plug type and correctly wired to provide proper grounding. Incorrectly wired extension cords may cause personal injury and equipment damage.

The fact that the equipment operates satisfactorily does not imply that the power is grounded and that the installation is completely safe. For your safety, if in any doubt about the effective grounding of the power, call a qualified electrician.

This product should be connected to an AC power source within the range indicated on the rating label. Do NOT connect it to a DC power source. If you are not sure, contact a qualified electrician.

Disconnect device

You must install this printer near a power outlet that is easily accessible. In case of an emergency, you must disconnect the power cord from the power outlet to shut off the power completely.

Caution for LAN connection

Connect this product to a LAN connection that is not subjected to overvoltages.

IT power system (For Norway only)

This product is also designed for an IT power system with phase-to-phase voltage 230V.

Geräuschemission / Acoustic noise emission (for Germany only)

Lpa < 70 dB (A) DIN 45635-19-01-KL2

Wiring information (for UK)

Important

If you need to replace the plug fuse, fit a fuse that is approved by ASTA to BS1362 with the same rating as the original fuse.

Always replace the fuse cover. Never use a plug that does not have a cover.

Warning - This printer must be earthed.

The wires in the mains lead are coloured in line with the following code:

Green and Yellow: Earth

Blue: Neutral

Brown: Live

If in any doubt, call a qualified electrician.

Trademarks

The Brother logo is a registered trademark of Brother Industries, Ltd.

Apple, the Apple Logo, and Macintosh® are registered trademarks in the United States and other countries, and TrueType is a trademark of Apple Computer, Inc.

Epson is a registered trademark and FX-80 and FX-850 are trademarks of Seiko Epson Corporation.

Hewlett Packard is a registered trademark and HP LaserJet 6P, 6L, 5P, 5L, 4, 4L 4P, III, IIIP, II, and IIP are trademarks of Hewlett-Packard Company.

IBM, IBM PC, and Proprinter are registered trademarks of International Business Machines Corporation.

Microsoft, MS-DOS, Windows and Windows NT are registered trademarks of Microsoft Corporation in the U.S. and other countries.

PostScript is a registered trademark of Adobe Systems Incorporated.

ENERGY STAR is a U.S. registered mark.

All other terms and brand and product names mentioned in this User's Guide are registered trademarks of their respective companies.

Compilation and Publication Notice

Under the supervision of Brother Industries Ltd., this manual has been compiled and published, covering the latest product's descriptions and specifications.

The contents of this manual and the specifications of this product are subject to change without notice.

Brother reserves the right to make changes without notice in the specifications and materials contained herein and shall not be responsible for any damages (including consequential) caused by reliance on the materials presented, including but not limited to typographical and other errors relating to the publication.

This printer contains UFST and Micro Type from Monotype Imaging Inc.

©2003 Brother Industries Ltd.

Shipment of the Printer

If for any reason you must ship your Printer, carefully package the Printer to avoid any damage during transit. It is recommended that you save and use the original packaging. The Printer should also be adequately insured with the carrier.

See *Shipping the printer* on page 5-28

Table of Contents

Definitions of warnings, cautions, and notes	i
To use the printer safely	ii
Printer do's and don'ts for optimum print quality	iv
Important information: Regulations	vii
Federal Communications Commission (FCC) Declaration of Conformity (For USA)	vii
Industry Canada Compliance Statement (For Canada)	viii
Radio interference (220 to 240 volt model only)	viii
International ENERGY STAR® Compliance Statement	ix
Laser Safety (100 to 120 volt model only)	ix
FDA Regulations (100 to 120 volt model only)	ix
IEC 60825 specification (220 to 240 volt model only)	x
IMPORTANT - For Your Safety	xi
Geräuschemission / Acoustic noise emission (for Germany only)	xi
Wiring information (for UK)	xi
Trademarks	xii
Compilation and Publication Notice	xii
Shipment of the Printer	xii
Table of Contents	xiv

1 About this printer	1-1
What is in the box?	1-1
Front view	1-3
Back view	1-4
Features	1-5
2400 DPI class resolution	1-5
High speed and color laser printing	1-5
Color Advanced Photoscale Technology (CAPT)	1-5
High Resolution Control (HRC)	1-5
Maintenance-free and economical toner cartridge	1-5
Universal paper tray	1-5
Three interfaces	1-5
Automatic Interface Selection	1-6
Five emulation modes	1-6
Automatic Emulation Selection	1-6
Data compression technology	1-6
Fonts	1-6
Panel lock setting	1-7
Power Save Mode	1-7
Toner Save Mode	1-7
Reprint setting	1-7
Network	1-7
Positioning the printer	1-8
Power Supply	1-8
Environment	1-8
What kind of paper can I use?	1-10
Type and size of paper	1-10
Suitable paper specifications	1-10
Recommended paper	1-12
Printable area	1-13
Portrait	1-13
Landscape	1-13
Guidelines for selecting paper	1-14
Envelopes	1-15
Labels and transparencies	1-17

Paper feed	1-18
Tray feed	1-18
Manual feed	1-19
Paper output	1-19
2 Driver and software	2-1
Printer driver	2-1
For Windows®	2-2
Features in the PCL printer driver	2-2
Basic Tab	2-2
Advanced tab	2-3
Accessories tab	2-8
Support Tab	2-9
Features in the PS printer driver	2-10
Ports tab	2-10
Device Settings tab	2-11
Layout tab	2-12
Paper / Quality tab	2-13
Advanced options	2-14
For Macintosh®	2-16
Software	2-18
Software for Networks	2-18
BRAdmin Professional utility	2-18
Driver Deployment Wizard	2-18
Web BRAdmin	2-18
Automatic Emulation Selection	2-19
Automatic Interface Selection	2-20
Printer settings	2-20
Factory settings	2-20
3 Control panel	3-1
Control panel	3-1
Buttons	3-2
Go button	3-3
Job Cancel button	3-3
+ or - button	3-3
To move through menus in the LCD	3-3
To enter numbers	3-3
Set button	3-3
Back button	3-4
Light-emitting diodes (LEDs)	3-5
Liquid crystal display (LCD)	3-6
LCD messages	3-6
Printer status messages	3-7
How to use the control panel	3-7
Control panel LCD menu	3-9
Set date and time	3-19
Set IP address	3-20
About emulation modes	3-21
List of factory settings	3-22
Network factory default setting	3-22
Reprint setting	3-26
Reprinting from RAM	3-26
Reprinting the last job	3-27
Printing PROOF data	3-28
Printing PUBLIC data	3-28

Printing SECURE data	3-29
When there is no reprint data in memory	3-31
To delete the job	3-31
To cancel the reprint job	3-31

4 Options 4-1

Optional accessories and supplies	4-1
Lower tray unit (LT-27CL)	4-1
Legal tray (LT-27LG)	4-1
Duplex unit (DX-2700)	4-1
CompactFlash® card	4-1
SO-DIMM memory	4-1
Optional fonts package	4-1
Lower tray unit (LT-27CL)	4-2
Putting paper in the lower tray unit	4-2
How to install the lower tray unit	4-2
Legal tray (LT-27LG)	4-5
How to install the legal tray	4-5
Duplex unit (DX-2700)	4-7
How to install the duplex unit	4-7
Guidelines for printing on both sides of the paper	4-10
Paper orientation for printing on both sides of the paper	4-10
CompactFlash® card	4-11
Inserting the CompactFlash® card	4-12
SO-DIMM	4-13
Installing additional memory	4-14
Optional fonts package	4-16
Optional fonts package (BS-3000)	4-16
Optional barcode fonts package (BT-1000)	4-16
Selecting the optional fonts	4-16

5 Routine maintenance 5-1

Replacing the consumable items	5-1
Toner cartridges	5-4
Toner nearly empty message	5-4
TONER EMPTY message	5-4
Replacing the toner cartridges	5-5
Waste toner pack	5-8
Waste toner pack full message	5-8
Replacing the waste toner pack	5-9
OPC belt cartridge	5-10
Replace OPC belt cartridge message	5-10
.....	5-10
Replacing the OPC belt cartridge	5-10
Fusing unit	5-13
Replace fusing unit message	5-13
Replacing the fusing unit	5-14
120K kit	5-16
Replacing the transfer belt cleaner	5-16
Replacing the transfer roller	5-18
Cleaning	5-21
Cleaning the outside of the printer	5-22
Cleaning the inside of the printer	5-23
Shipping the printer	5-28

6	Troubleshooting	6-1
	LCD messages	6-1
	Error messages	6-1
	Maintenance messages	6-3
	Call service messages	6-4
	Paper jams and how to clear them	6-7
	JAM A1 / JAM A2 (paper jam in the paper tray)	6-8
	JAM B (paper jam at the entrance to the fusing roller)	6-9
	JAM C (paper jam where the paper comes out of the printer)	6-11
	JAM D (paper jam in the lower part of the duplex unit)	6-13
	JAM E (paper jam in the upper part of the duplex unit)	6-14
	Improving the print quality	6-16
	Q & A	6-20
	Setting up the printer hardware	6-20
	Setting up the printer	6-21
	Paper handling	6-22
	Printing	6-23
A	Appendix	A-1
	Printer specifications	A-1
	Printing	A-1
	Features	A-2
	Electrical and mechanical	A-3
	Paper specifications	A-4
	Paper handling	A-4
	Media specifications	A-4
I	INDEX	I-1

1 About this printer

What is in the box?

⚠ This printer is heavy and weighs approximately 31.5 kg (69.4 lb). To prevent injuries when moving or lifting this printer, make sure to use at least two people.

When you unpack the printer, check to see that you have all of the following parts:

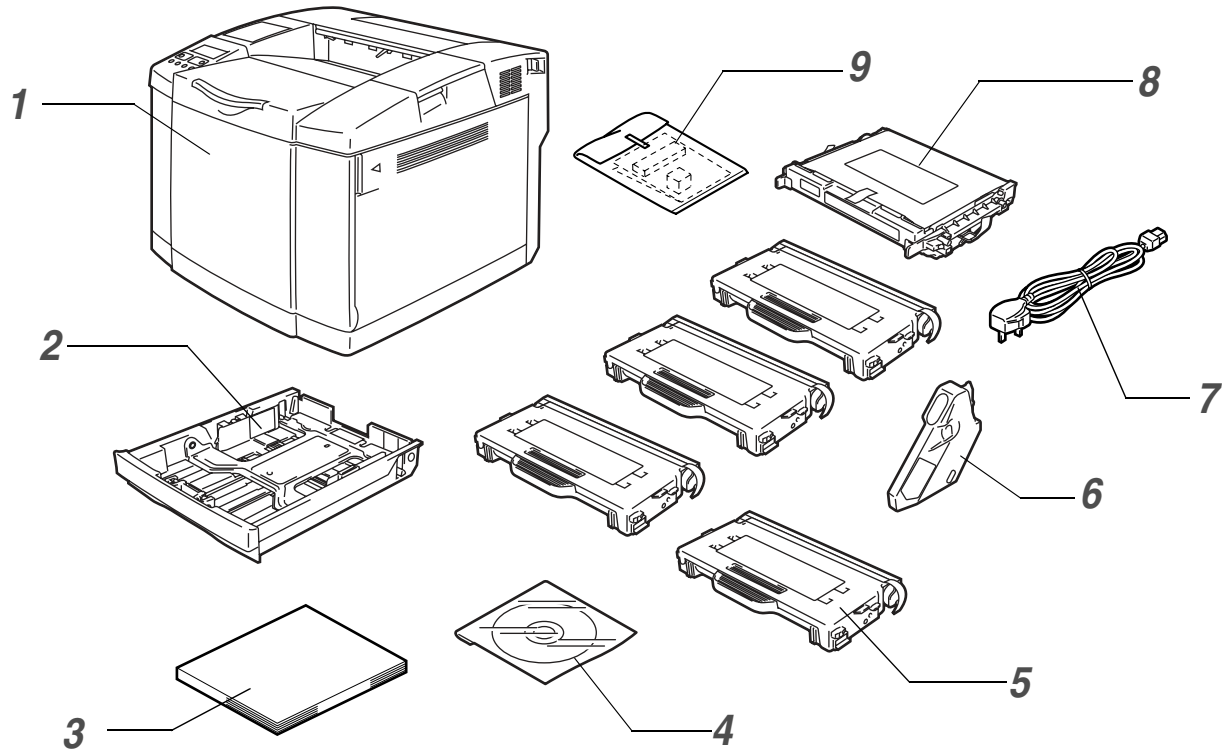

Figure 1-1

- 1 Printer
- 2 Standard Paper Tray (pre-installed)
- 3 Quick Setup Guide*²
- 4 CD-ROM*²
- 5 Toner Cartridges*¹ (pre-installed) (Black [TN04BK], Cyan [TN04C], Magenta [TN04M], Yellow [TN04Y])
- 6 Waste Toner Pack (pre-installed) [WT-4CL]
- 7 AC Power Cord*²
- 8 OPC Belt Cartridge [OP-4CL]
- 9 Repacking kit*³

*1 The toner cartridges that come supplied with this printer, are starter toners.

Starter toners, are toner cartridges with up to half the life of the standard toner cartridge, 5000 pages (Black) and 3000 pages (Cyan, Magenta and Yellow) at approximately 5% print coverage (A4 or Letter size).

*2 In Europe these parts are in the Localization Kit.

*3 Repacking kit is to be used ONLY for moving or shipping the printer. Localization Kit.

 Depending on the country you live in and the HL-2700CN series model bought, you may have additional parts not listed above.

 The OPC belt cartridge is packed inside a separate box as a starter kit. Wait to unpack the OPC belt cartridge until immediately before you put it in the printer. Exposure to direct sunlight or room light may damage the OPC belt cartridge.

 We recommend keeping spares of the following consumable items at all times. When these are exhausted, the printer may stop printing.

- Toner cartridges (TN-04BK, TN-04C, TN-04M, TN-04Y)
- Waste toner pack (WT-4CL)
- OPC belt cartridge (OP-4CL)

Interface cable

- An interface cable is not a standard accessory.
- Some computers have a USB and a parallel port. Please buy the appropriate cable for the interface you are going to use.
- Most parallel cables support bi-directional communication, but some might have an incompatible pin assignment or may not be IEEE 1284 compliant.
- It is recommended to use a parallel interface cable or USB interface cable that is no longer than 6 feet (2 meters).
- When you use a USB cable, make sure it is a high-speed twisted cable (12 Mbps or 480 Mbps), and that you connect it to the USB connector of your PC.
- Please make sure that you use a Hi-Speed USB 2.0 certified cable if your computer uses a Hi-Speed USB 2.0 interface.
- Do not connect the USB cable to a non-powered hub or Mac[®] Keyboard.

 Depending on the country where you bought the printer, the power cord may differ slightly from the one shown in Figure 1-1.

Front view

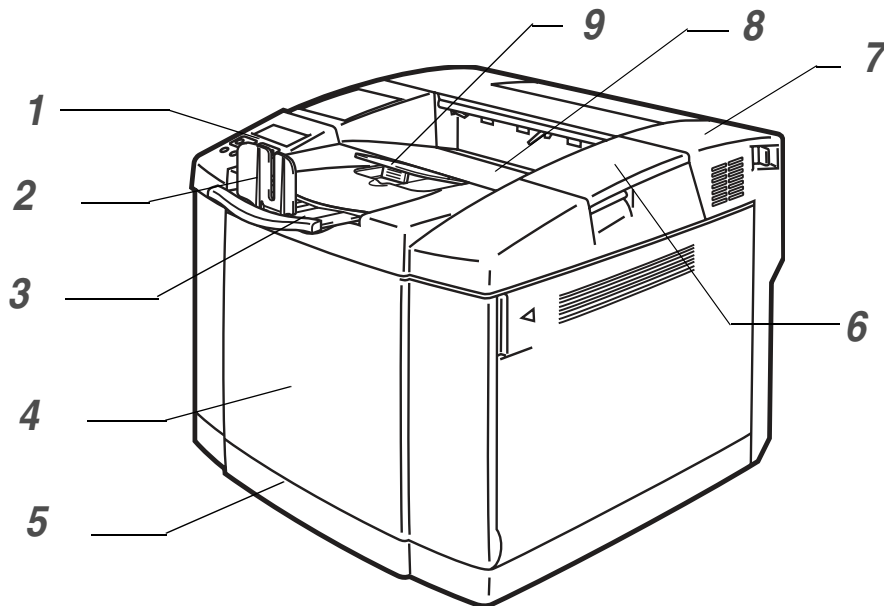

Figure 1-2

- 1 Control Panel
- 2 Paper Stopper
- 3 Face-down Output Tray Extension
- 4 Front Cover
- 5 Paper Tray
- 6 Top Cover
- 7 Back Cover
- 8 Face-down Output Tray
- 9 Paper Support

Back view

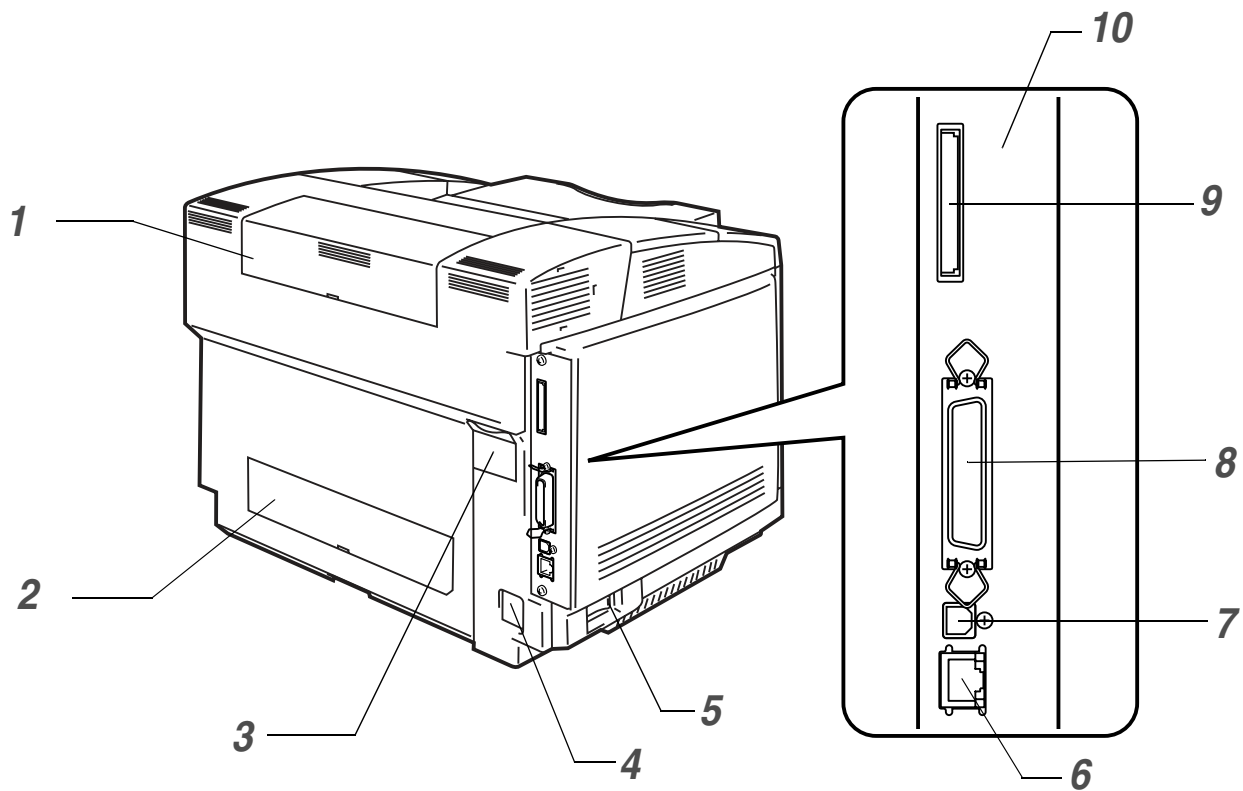

Figure 1-3

- 1** Duplex Upper Cover
- 2** Duplex Lower Cover
- 3** Duplex Cap
- 4** AC Power Connector
- 5** Power Switch
- 6** Ethernet 10/100BASE-TX Port
- 7** USB Interface Connector
- 8** Parallel Interface Connector
- 9** Card Slot (For optional CompactFlash® card)
- 10** Controller Board

Features

This printer has the following standard features.

2400 DPI class resolution

This printer prints at a default resolution of 600 dots per inch (dpi). You can get a higher print quality, equivalent to 2400 dpi class resolution by using Brother technologies: High Resolution Control (HRC) and Color Advanced Photoscale Technology (CAPT).

High speed and color laser printing

You can print crisp images in brilliant 24-bit color.

This printer can print at speeds up to 29 pages per minute in monochrome mode and 8 pages per minute in full color mode. The HL-2700CN controller uses a high speed 64-bit RISC microprocessor and special hardware chips, to ensure fast print job processing.

Color Advanced Photoscale Technology (CAPT)

This printer can print graphics in 256 shades for each color in PCL6 emulation and BR-Script3, producing nearly photographic quality. CAPT is most effective when printing photographic images.

High Resolution Control (HRC)

The High Resolution Control (HRC) technology gives you clear and crisp printouts and improves even 600-dpi resolution output. HRC is most effective when printing text.

Maintenance-free and economical toner cartridge

This printer uses four easy-to-replace toner cartridges. The toner cartridges can print up to 6,600 (Cyan, Magenta and Yellow) and 10,000 (Black) single-sided pages at approximately 5% coverage.

Universal paper tray

This printer loads paper automatically from the paper tray. Since the paper tray is a universal type, a number of different paper sizes (one paper size at a time) can be used. Even envelopes can be loaded from the paper tray. For detailed paper specifications, see *What kind of paper can I use?* on page 1-10.

Three interfaces

This printer has a high speed, bi-directional parallel, a Hi-Speed USB 2.0, and an Ethernet 10/100BASE-TX interface.

If your application software supports the bi-directional parallel interface, you can monitor the printer status. It is fully compatible with the industry-standard bi-directional parallel interface.

The Brother network board is factory installed in the HL-2700CN, which enables you to use this printer in the TCP/IP, IPS/SPX, AppleTalk, DLC/LLC and NetBEUI environments. Also, many useful utilities, such as BRAdmin Professional utility for the administrator and Brother network printing software, are included in the CD-ROM supplied with the HL-2700CN printer. For setup, see the *Network User's Guide*, which is provided on the CD-ROM.

Automatic Interface Selection

This printer can automatically select the bi-directional parallel, USB or Ethernet 10/100BASE-TX interface, depending on the interface port through which it receives data. With this feature, you can connect the printer to more than one computer. See *Automatic Interface Selection* on page 2-20.

Five emulation modes

This printer can emulate PCL 5C and PCL 6 language printers, Brother BR-Script3 printers, HP-GL plotter as well as EPSON FX-850 and IBM Proprinter XL printers (for monochrome printing only). You can print with all application programs that support one of these printers. See *About emulation modes* on page 3-21.

Automatic Emulation Selection

This printer can automatically select the printer emulation mode, depending on the print commands it receives from the computer software. With this feature, many users can share the printer on a network. See *Automatic Emulation Selection* on page 2-19.

Data compression technology

This printer can internally compress the received graphics and font data in its memory so it can print larger graphics and more fonts without the need for additional memory.

Fonts

This printer has 66 scalable and 12 bitmapped fonts. The fonts that can be used vary according to the selected emulation mode.

In PCL mode, you can also print the 13 kinds of bar codes listed below. In BR-Script mode, the printer has 35 scalable fonts.

Bar code printing

This printer can print the following 13 types of bar codes:

- Code 39
- Interleaved 2 of 5
- EAN-8
- EAN-13
- EAN-128
- Code 128
- UPC-A
- UPC-E
- Codabar
- FIM (US-PostNet)
- Post Net (US-PostNet)
- ISBN (EAN)
- ISBN (UPC-E)

Panel lock setting

If the panel button settings have been changed, the printer may not work as you expect. If you are an administrator of this printer, you can lock your settings to prevent changes from being made. See *SETUP* on page 3-12.

Power Save Mode

This printer has a power saving mode. Since laser printers consume power to keep the fixing assembly at a high temperature, this feature can save electricity when the printer is on but not being used. The factory setting of the power save mode is **ON** so that it complies with the new EPA Energy Star specification.

Toner Save Mode

This printer has an economical toner save mode. By using this feature you can substantially reduce operating costs and extend the life expectancy of the toner cartridges.

Reprint setting

The printer saves data that you want reprinted. You can reprint a document without sending the data again from your PC. If you do not install a CompactFlash® card, you can reprint from RAM. See *Reprint setting* on page 3-26.

When there is not enough memory to print the last job, you can reprint the last print page.

Network

Ethernet 10/100BASE-TX enables you to use the printer in the following environments:

(TCP/IP, IPX/SPX, AppleTalk, DLC/LLC, NetBEUI)

Also, many useful utilities, such as BRAdmin Professional Utility, Driver Deployment Wizard and Web BRAdmin software for the Network administrator, are included. For details of the utilities, see the documentation included on the CD-ROM. See *Software for Networks* on page 2-18.

Positioning the printer

Please read the following before you use the printer.

Power Supply

Use the printer within the recommended power range.

AC power: $\pm 10\%$ of the rated power voltage

Frequency: 50/60 Hz (120 V or 220-240 V)

The power cord, including extensions, should not exceed 5 meters (16½ feet).

Do not share the same power circuit with other high-power appliances, such as an air conditioner, copier, shredder and so on. If you cannot avoid using the printer with these appliances, we recommend that you use a voltage transformer or a high-frequency noise filter.

Use a voltage regulator if the power source is not stable.

Environment

- Make sure that the power outlet/socket is near the printer and is easy to get to so that, if there is an emergency, it can be easily unplugged.
- Use the printer only within the following ranges of temperature and humidity:

Temperature: 10 °C to 32.5 °C (50 °F to 90.5 °F)

Humidity: 20% to 80% (without condensation)

- Do not put the printer where the ventilation hole of the printer is blocked. Keep a gap of approximately 100 mm (4 in.) between the ventilation hole and the wall.
- The printer should be used in a well-ventilated room.
- Put the printer on a flat, horizontal surface.
- Keep the printer clean. Do not put the printer in a dusty place.
- Do not put the printer in direct sunlight. If you have to put it near a window, use a blind or a heavy curtain to protect the printer from direct sunlight.
- Do not put the printer near devices that contain magnets or generate magnetic fields.
- Do not subject the printer to strong physical shocks or vibrations.
- Do not expose the printer to open/naked flames or salty or corrosive gasses.
- Do not put objects on top of the printer.
- Do not put the printer near an air conditioner.
- Keep the printer horizontal when you carry it.
- Do not place anything on top of the power cord including this machine. Do not allow the power cord to be stepped on.

The following figure details the recommended area around the printer for proper ventilation, operation and maintenance.

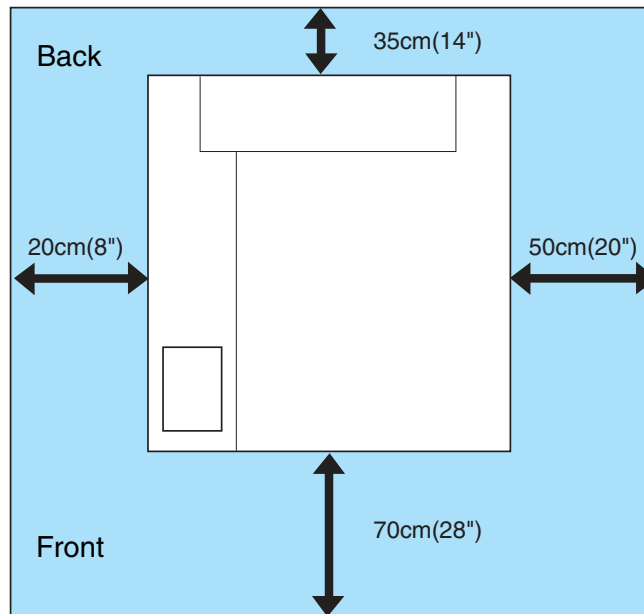

Figure 1-4

- Make sure that there is enough space behind the printer so you can easily access the back cover or duplex unit if a paper jam occurs.
- Make sure the paper tray does not extend past the edge of the table where the printer is located.

What kind of paper can I use?

Type and size of paper

The printer loads paper from the installed standard paper tray, optional lower tray, or the optional legal tray.

Standard paper tray

Since the standard paper tray is a universal type, you can use any of the paper sizes (one paper size at a time) listed in table 1 in *Media type, paper size and number of sheets for paper source* on page 1-11. The tray can hold up to 250 sheets of paper (75 g/m² or 20 lb) or up to 15 envelopes (paper can be loaded up to the top line of the sliding guide).

Optional lower tray (LT-27CL)

The optional lower tray can hold up to 530 sheets of paper (75 g/m² or 20 lb). The maximum capacity is 44 mm paper height.

Optional legal tray (LT-27LG)

The optional legal tray can hold up to 250 sheets of paper (75 g/m² or 20 lb). If you want to print on legal size paper, you must use this tray. You can use the optional legal tray as a standard paper tray (Tray 1). See *Legal tray (LT-27LG)* on page 4-5.

The names for the paper trays in the printer driver and this Guide are as follows:

Tray and optional unit	Name
Standard paper tray Optional legal tray	Tray 1
Optional lower tray	Tray 2
Optional duplex unit for duplex printing	DX

Suitable paper specifications

The following paper specifications are suitable for this printer.

Basis weight (g/m²)	75-90
Thickness (µm)	80-110
Roughness (sec.)	Higher than 20
Stiffness (cm³/100)	90-150
Grain direction	Long grain
Volume resistivity (ohm)	10e ⁹ -10e ¹¹
Surface resistivity (ohm-cm)	10e ¹⁰ -10e ¹²
Filler	CaCO ₃ (Neutral)
Ash content (wt%)	Below 23
Brightness (%)	Higher than 80
Opacity (%)	Higher than 85

Table 1: Media type, paper size and number of sheets for paper source

Media type	Tray 1	Tray 2	DX	Select the Media type from the printer driver
Plain paper 60 to 90 g/m ² (16 to 24 lb)	①	①	①	Plain paper or Thin paper
Thick paper 90 to 210 g/m ² (24 to 55 lb)	①	① 90 to 105 g/m ² (24 to 28 lb)	① 90 to 105 g/m ² (24 to 28 lb)	Thick paper or Thicker paper
Transparency	① Up to 50 sheets A4 or Letter			Transparencies
Labels	①			Thick paper
Envelopes	①			Envelopes Envelopes - Thin Envelopes - Thick

		Tray 1	Tray 2	DX
Paper size		A4, Letter, B5 (JIS/ISO), Executive, A5, COM10, DL, 104.8 x 210 mm to 215.9 x 297 mm (4.1 x 8.3 in. to 8.5 x 11.7 in.)	A4, Letter, B5 (JIS/ISO), Executive	A4, Letter, Legal, B5 (JIS/ISO), Executive, A5 104.8 x 210 mm to 215.9 x 355.6 mm (5.8 x 8.3 in. to 8.5 x 14 in.)
Number of sheets	Plain paper	Up to 250 sheets (75 g/m ² or 20 lb)	Up to 530 sheets (75 g/m ² or 20 lb)	
	Thick / Thicker paper	Up to 40 sheets (165 g/m ² or 44 lb)	Up to 44 mm loading height	
	Transparencies	Up to 50 sheets		
	Labels	Up to 80 sheets		
	Envelopes	Up to 15 sheets or 7 sheets for H/H* condition.		

* H/H = High temperature/High humidity

Recommended paper

The recommended paper for this printer is:

Xerox 4200, Hammermill Laserprint

NEUSIEDLER Color Copy 90g/m² or equivalent



- To get the best output quality and to avoid any damage, use smooth white paper.
- Before you buy a lot of paper, please test some to make sure that the paper is suitable.
- Use neutral paper. Do not use acidic or alkaline paper.
- Print quality will vary depending on the paper being used.



Do not load envelopes, transparencies, labels or thick paper (more than 105 g/m² or 28 lb) into the optional lower tray unit. It may cause paper jams.

Printable area

When using PCL emulation, the edges of the paper that cannot be printed on are shown below.

Portrait

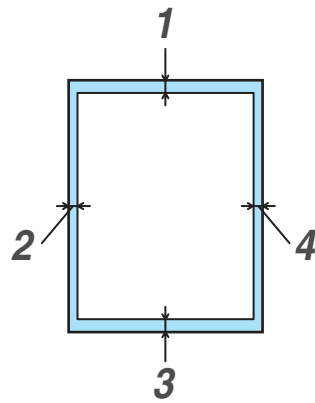

Figure 1-5

	For all available paper sizes
1	4.2 mm (0.17 in.)
2	4.2 mm (0.17 in.)
3	4.2 mm (0.17 in.)
4	4.2 mm (0.17 in.)

Landscape

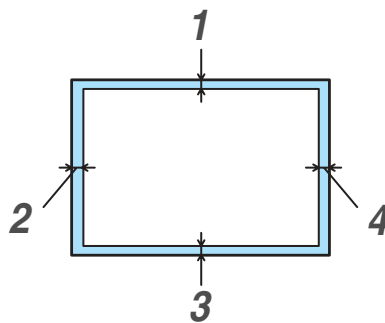

Figure 1-6

	For all available paper sizes
1	4.2 mm (0.17 in.)
2	4.2 mm (0.17 in.)
3	4.2 mm (0.17 in.)
4	4.2 mm (0.17 in.)

Guidelines for selecting paper

The printer is designed to work well with most types of xerographic and bond paper. However, some paper variables may have an effect on print quality or handling reliability. Always test samples of paper before purchasing to ensure desirable performance. Some important guidelines when selecting paper are:

- Supplier should be informed that the paper or envelopes will be used in a laser printer.
- Preprinted paper must use inks that can withstand the temperature of the printer's fusing process. (200 degrees centigrade)
- If you have selected a cotton bond paper, paper having a rough surface, such as cockle or laid finished paper or paper that is wrinkled or puckered, the paper may exhibit degraded performance.



The manufacturer does not recommend the use of any particular paper. The operator is responsible for the quality of paper used with the printer.

Types of paper to avoid

Some types of paper may not perform well or may cause damage to your printer.

Do not use paper:

- that is highly textured
- that is extremely smooth or shiny
- that is curled or warped
- that is coated or has a chemical finish
- that is damaged, creased or folded
- that exceeds the recommended weight specification in this guide
- with tabs and staples
- with letterheads using low temperature dyes or thermography
- that is multipart or carbonless
- that is designed for inkjet printing

If you use any of the types of paper listed above, they may damage your printer. This damage is not covered under any Brother warranty or service agreement.

Envelopes

Types of envelopes to avoid

Do not use envelopes:

- that are damaged, curled, wrinkled, or an unusual shape
- that are extremely shiny or textured
- with clasps, snaps or tie strings
- with self-adhesive closures
- that are of a baggy construction
- that are not sharply creased
- that are embossed (have raised writing on them)
- that were previously printed by a laser printer
- that are pre-printed on the inside
- that cannot be arranged when put in a pile
- that are made of paper that weighs more than the paper weight specifications for the printer
- that have been badly made, with edges that are not straight or consistently square
- with windows, holes, cut-outs or perforations
- with sealing flaps that have not been folded at purchase
- with sealing flaps as shown in Figure 1-7
- with three or more layers of paper in the marked area in Figure 1-8 or
- with each side folded as shown in Figure 1-9

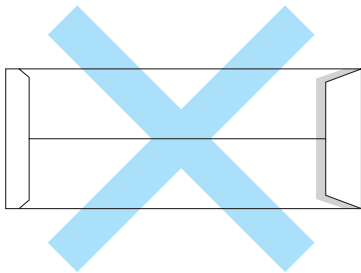

Figure 1-7

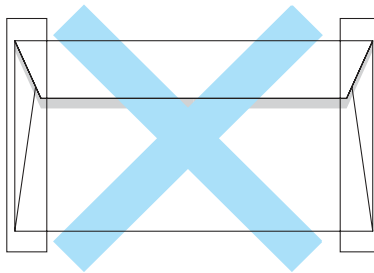

Figure 1-8

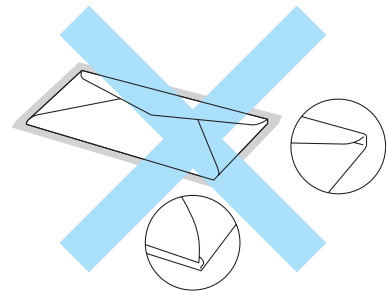

Figure 1-9

Before you put envelopes in the tray, check the following:

- Envelopes should have a lengthwise sealing flap.
- The sealing flaps should be folded crisply and correctly (irregularly cut or folded envelopes may cause paper jams).

- Envelopes should consist of two layers of paper in the area circled in Figure 1-10.

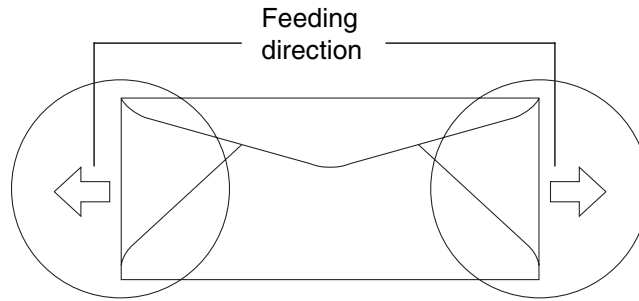

Figure 1-10

If you use any of the types of envelopes listed above, they may damage your printer. This damage is not covered under any Brother warranty or service agreement.

- Before you print envelopes, you must 'fan' the stack to avoid paper jams and misfeeds.
- Before you print a lot of envelopes, test one to make sure that the print results are what you want.
- Envelope joints that are sealed by the manufacturer should be secure.
- Do not put different types of paper in the paper tray at the same time because it may cause paper jams or misfeeds.
- For proper printing, you must choose the same paper size from your software application as the paper in the tray.
- An area 15 mm (0.6 in.) from the edges of the envelope will not be printed.
- See *What kind of paper can I use?* on page 1-10.

Most envelopes will be suitable for your printer. However, some envelopes will have feed and print-quality problems because of the way they have been made. A suitable envelope should have edges with straight, well-creased folds and the leading edge should not be thicker than two pieces of paper. The envelope should lie flat and not be of baggy or flimsy construction. You should buy quality envelopes from a supplier who understands that you will be using the envelopes in a laser printer.

- Brother will not recommend a particular envelope because envelope manufacturers may change the envelope specifications. You are responsible for the quality and performance of the envelopes you use.

Labels and transparencies

The printer will print on most types of labels and transparencies designed for use with a laser printer. Labels should have an adhesive which is acrylic-based since such material is more stable at the high temperatures in the fusing unit. Adhesives should not come in contact with any part of the printer, because the label stock may stick to the drum or rollers and cause jams and print quality problems. No adhesive should be exposed between the labels. Labels should be arranged so that they cover the entire length and width of the sheet. Using labels with spaces may result in labels peeling off and causing serious jams or print problems.

All labels and transparencies used in this printer must be able to withstand a temperature of 200 degrees centigrade (392 degrees Fahrenheit) for a period of 0.1 seconds.

Label and transparency sheets should not exceed the paper weight specifications described in this User's Guide. Labels and transparencies exceeding this specification may not feed or print properly and may cause damage to your printer.

Transparencies and Labels can be fed from Tray 1 only and cannot be printed using the duplex unit.

Types of labels and transparencies to avoid

Do not use labels or transparencies that are damaged, curled, wrinkled or an unusual shape.

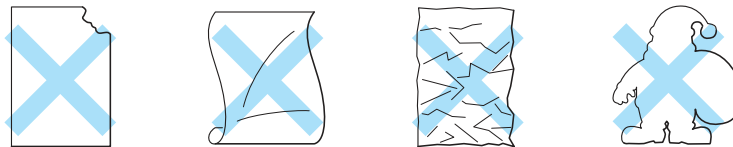

Figure 1-11



Before using paper that has holes in it, such as organizer sheets, you must 'fan' the stack to avoid paper jams and misfeeds.



Figure 1-12



■ Avoid feeding labels with the carrier sheet exposed because your printer will be damaged.

■ When feeding transparencies, use the recommended type for *laser* printers. For detailed information on the specification of the proper transparencies to purchase, call your dealer or Brother Customer Service.



Brother will not recommend particular labels or transparencies because the manufacturers may change the specifications. You are responsible for the quality and performance of the print media you use.

Paper feed

Tray feed

The printer can feed paper from the standard paper tray, optional lower tray or optional legal tray.



When you put paper into the paper tray, note the following:

- If your application software supports paper size selection on the print menu, you can select it through the software. If your application software does not support it, you can set the paper size in the printer driver or by using the control panel buttons.
- The paper size has been set at the factory to Letter for 120 V models or A4 for 220/240 V models. If you want to use other sizes of paper or envelopes, change the paper size setting in PAGE FORMAT in the FORMAT menu by using the control panel buttons. For paper size selection, see *PRINT MENU* on page 3-13.
- If you use pre-printed paper in the trays, please be sure to put the paper with the printed side face up and the top edge of the paper at the back of the paper tray.

The printer automatically detects the paper size you have put into the paper tray. The printer will prompt you to put the correct size of paper in the tray as follows:

```
SIZE MISMATCH
Put <size> paper size in Tray
<1/2>. Paper mismatch between
the Printer and the Printer
Driver setting
```

If you want to put a different size of paper into the paper tray from the size that was selected in the paper size setting by using the control panel buttons or in your application software, you can change the paper size setting.

Print on envelopes

Adjust the paper length and width guides to fit the envelopes that are going to be used.

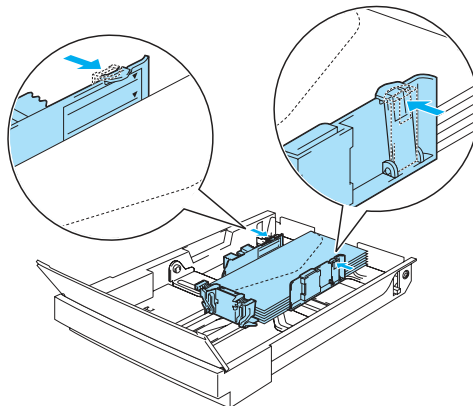

Figure 1-13

Manual feed

Since this printer does not have a manual feed or multi purpose tray, you cannot manually feed irregular sized paper. However, this printer has a special manual feed mode using Tray 1 (standard paper tray) to accommodate non-standard paper sizes. You can select this mode with the printer driver or the control panel buttons.

See *PAPER* in Chapter 3 for more information on selecting this setting using the printer control panel buttons.

- 1 When the manual feed command is selected, the printer waits until you put the paper in Tray 1.

MANUAL FEED
=ON

- 2 Pull out Tray 1 and put in the paper you are going to use. It may be necessary to remove some or all of the paper stack first, depending on the size of paper in the tray and the size of the paper you wish to print on manually.

- 3 Put Tray 1 back in and press **Go**. The printer will then start printing.



- Print quality may be affected by the type of paper you use and the print image.
- You may experience poor paper feeding during duplex printing.
- You cannot perform continuous duplex printing when MANUAL FEED is on.
- During manual duplex printing, if you leave the printer for more than 5 minutes after the first side has been printed, the printer will reset this setting automatically.

Paper output

We recommend that you use the face down output tray extension, paper stopper and paper support:

- 1 when printing a lot at any one time
- 2 when using legal sized paper
- 3 if the printed paper appears curled

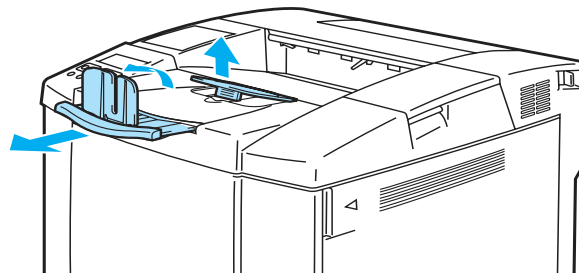

Figure 1-14

2 Driver and software

Printer driver

A Printer Driver is software that translates data from the format used by a computer to the format that a particular printer needs. Typically, this format is a printer command language or page description language.

The printer drivers for the following operating systems are on the CD-ROM that we have supplied. You can also download the latest printer driver from the Brother Solutions Center at <http://solutions.brother.com>

You can see the operations and detailed information in the **Install Software** section of the supplied CD-ROM.

For Windows® 95/98/Me, Windows® NT 4.0 and Windows® 2000/XP

- PCL (Hewlett-Packard laser printer-LaserJet) compatible driver
- BR-Script (PostScript® 3™ language emulation) driver

For Macintosh®

- BR-Script (PostScript® 3™ language emulation) driver (For more information, see the Network User's Guide on the CD-ROM.)

	PCL driver	PS driver
Windows® 95/98/Me	①	①
Windows® 2000/XP	①	①
Windows NT® 4.0	①	①
Macintosh® (via Network)		①
Macintosh® (via USB)		①



- For more information about emulations, see *About emulation modes* on page 3-21.
- If you want to print from a DOS application, see Chapter 6.
- The screen shot may vary depending on the Operating System (OS) you are using.

For Windows®

Features in the PCL printer driver

You can also download the latest printer driver or get other information by accessing the Brother Solutions Center at <http://solutions.brother.com>

You can also change settings by clicking the illustration on the left side of the **Basic** tab in the **Properties** dialog box.

For more information, please see the online **Help** in the printer driver.

 The screens in this section are from Windows® XP. The screens on your PC will vary depending on your operating system.

Basic Tab

 If you are using Windows NT® 4.0, Windows® 2000 or XP, you can access the **Basic** tab by clicking **Printing Preferences...** in the **General** tab of the **Brother HL-2700CN series Properties** screen.

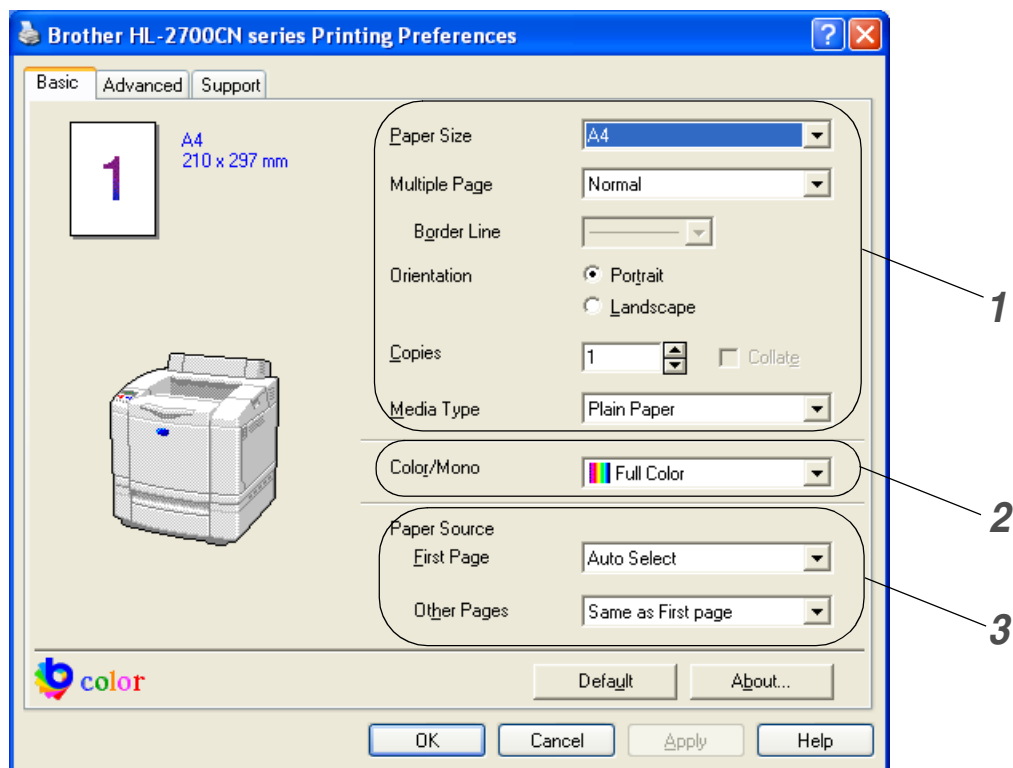

- 1 Select the **Paper Size**, **Multiple Page**, **Orientation** and other settings.
- 2 Select the color mode.
- 3 Select the **Paper Source**.

Advanced tab

 If you are using Windows NT® 4.0, Windows® 2000 or XP, you can access the **Advanced** tab by clicking **Printing Preferences...** in the **General** tab of the **Brother HL-2700CN series Properties** screen.

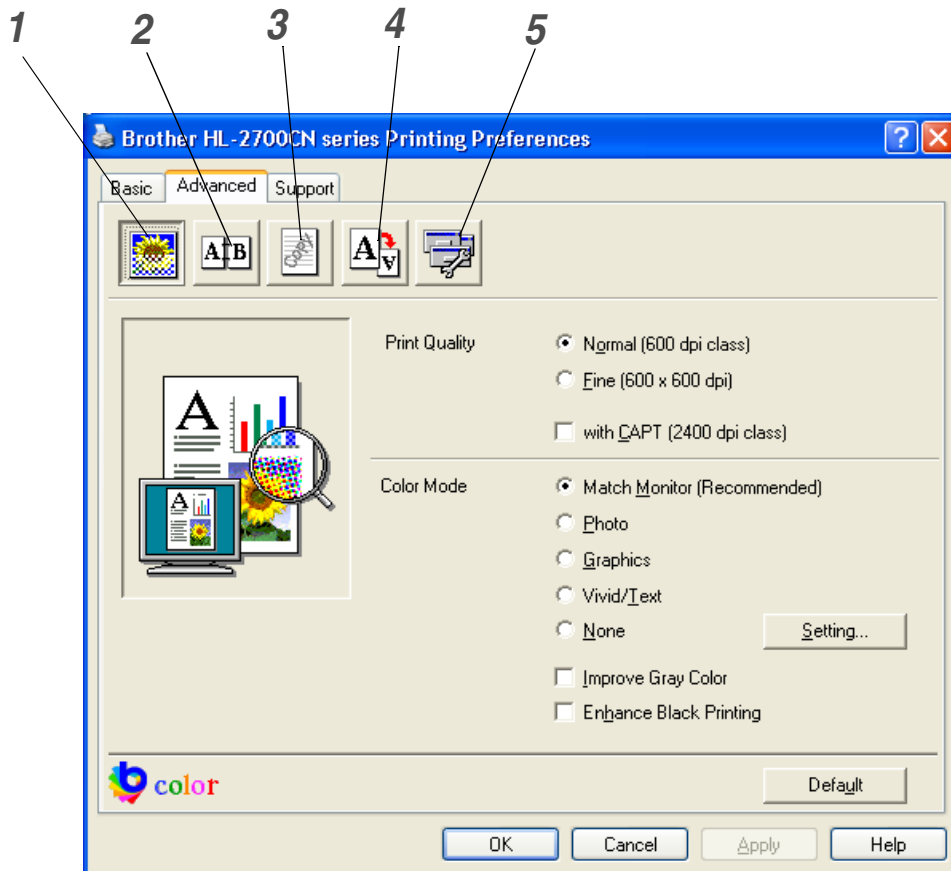

Change the tab settings by clicking the following icons:

- 1 *Print Quality*
- 2 *Duplex*
- 3 *Watermark*
- 4 *Page Setting*
- 5 *Device Options*

Print Quality

Select the Quality, Color Mode, Improve Gray Color and Enhance Black Printing.

■ Quality

You can select the following print quality settings.

- Normal 600 dpi class. Recommended for ordinary printing. Good print quality with reasonable print speeds.
- Fine 600 x 600 dpi. Print quality is higher. As a result, there will be more print data than when printing in Normal mode. This also causes longer print processing, data transfer and printing times.
- with CAPT* Choosing CAPT in the printer driver produces clearer colors and improves the appearance of print jobs containing photographic images.

*CAPT (Color Advanced Photoscale Technology)

It uses the color information contained in the image data to control the printed image color level. This results in a more accurate reproduction of the image. With CAPT On, the output resolution will be 2400 dpi class. This mode is recommended to print images and graphics.



Print quality and print speeds are correlated. Higher print quality takes longer to print, while lower print quality takes less time to print.

■ Color Mode

You can change the Color Matching mode as follows:

- Match Monitor
- Photo
- Graphics
- Vivid / Text
- None

■ Improve Gray Color

You can improve the image quality of shaded areas by ticking the Improve Gray Color check box.

■ Enhance Black Printing

If the black graphic cannot be printed correctly, make the setting here.

Duplex

To use automatic duplex printing, you will need to install the optional duplex unit onto your printer. If you select the **Duplex** button, the dialog box for making duplex settings will appear. Six types of duplex binding directions are available for each orientation.

Watermark

You can place a watermarked logo or text in your documents.

When you use a bitmap file as a watermark, you can change the size of the watermark and place it anywhere you like on the page.

When you use text as a watermark, you can change the font, darkness and angle settings.

Page Setting

Change the print image scaling, and then select **Mirror / Reverse print** options.

Device Options

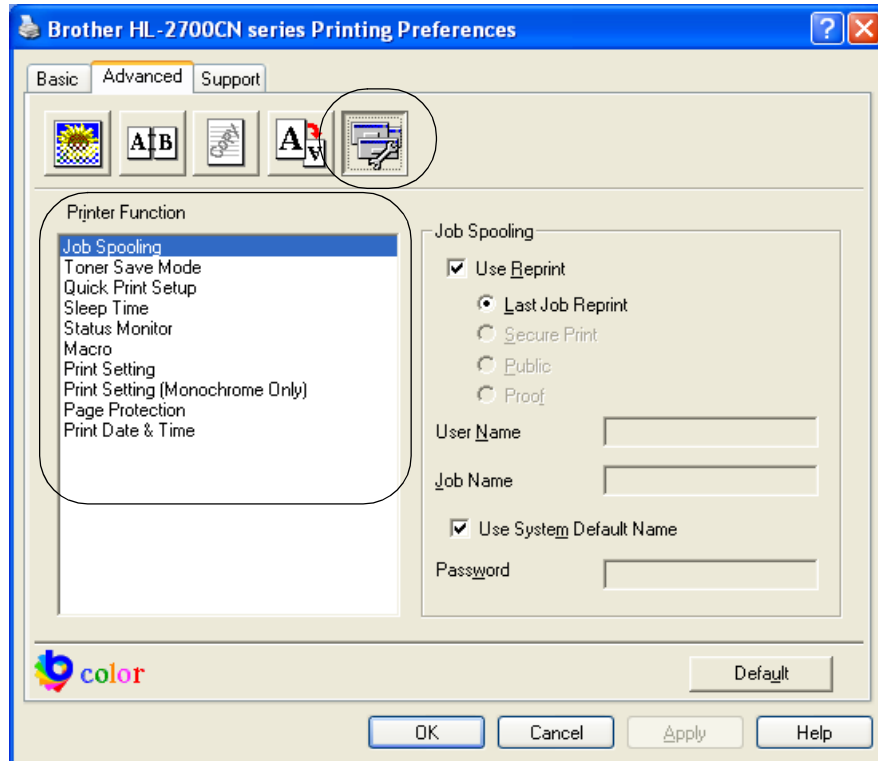

Set the following print functions in this tab:

- *Job Spooling*
- *Toner Save Mode*
- *Quick Print Setup*
- *Sleep Time*
- *Status Monitor*
- *Macro*
- *Administrator (For Windows® 95/98/Me users only)*
- *Insert Command/File (For Windows® 95/98/Me users only)*
- *Print Setting*
- *Print Setting (Monochrome Only)*
- *Page Protection*
- *Print Date & Time*

Job Spooling

You can reprint a document without sending the data again from your PC (except for secure printing) because the printer will save data that you specify for reprinting.

- Last Job Reprint: Reprint the last job
- Secure Print: Print the data with a password
- Public: Save the data without a password
- Proof: Save the data and print it

For more information about the Reprint setting, see *Reprint setting* on page 3-26.



- If you want to prevent other people from using the Reprint setting to print your data, remove the **Use Reprint** check mark in Job Spooling settings.
 - The settings for Job Spooling in the printer driver will take priority over the settings made on the control panel. See *Reprint setting* on page 3-26.

Toner Save Mode

You can save running costs by turning on the toner save mode, which reduces the print density.

Quick Print Setup

You can turn the **Quick Print Setup** function ON or OFF. A small selection window appears on your computer. This will then let you make changes to the settings of the following functions:

- Multiple Page
- Duplex
- Toner Save Mode
- Paper Source
- Media Type
- Color / Mono

Sleep Time

When the printer does not receive data for a certain period of time (time-out), it enters sleep mode. Sleep mode acts as though the printer was turned off. The default time-out is 30 minutes. When **Intelligent Sleep Mode** is selected, it is automatically adjusted to the most suitable time-out setting depending on the frequency of your printer use. While the printer is in sleep mode, the printer can still receive data from the computer. Receiving a print file or document automatically wakes up the printer to start printing. Pressing one of the buttons will also wake up the printer.

Sleep mode can be turned off. To turn sleep mode off, go to the **Advanced** tab, select **Device Options** and then select **Sleep Time**. Double-click the word **Sleep Time** in the **Sleep Time** screen, this will allow the **Sleep Time Off** function to appear, click **Sleep Time Off** to stop the printer going into sleep mode. The **Sleep Time Off** function can be hidden by double-clicking the word **Sleep Time** in the **Sleep Time** screen again. We recommend that you keep Sleep mode on for power saving.

Status Monitor

This reports the printer status (any errors that may happen with the printer) when printing. The default setting for the **Status Monitor** is off. If you would like to turn the status monitor on, go to the **Advanced** tab, select **Device Options** and then select **Status Monitor**.

Macro

You can save a page of a document as a macro to printer memory. Moreover, you can execute the saved macro - in other words, you can use the saved macro as an overlay on any documents. This will save time and increase printing speed for often used information such as forms, company logos, letter head formats or invoices.

Print Setting

You can change the settings of the following functions:

- Compression Mode
- TrueType Mode
- Use Printer TrueType Fonts

Print Setting (Monochrome Only)

You can change the settings of the following functions:

- HRC

Page Protection

Page Protection refers to a setting that reserves additional memory for the creation of full page images. Selections are AUTO, OFF, LTR (Letter size paper), A4 or LGL (Legal size paper).

The page protection feature allows the printer to create the full page image to be printed in memory before physically moving the paper through the printer. When the image is very complicated and the printer has to wait to process the image before printing, use this function.

Print Date & Time

Date: Specifies the format of the date.

Time: Specifies the format of the time.

Accessories tab

When you install optional units, you can add them and select the settings for them in the **Accessories** tab as follows.

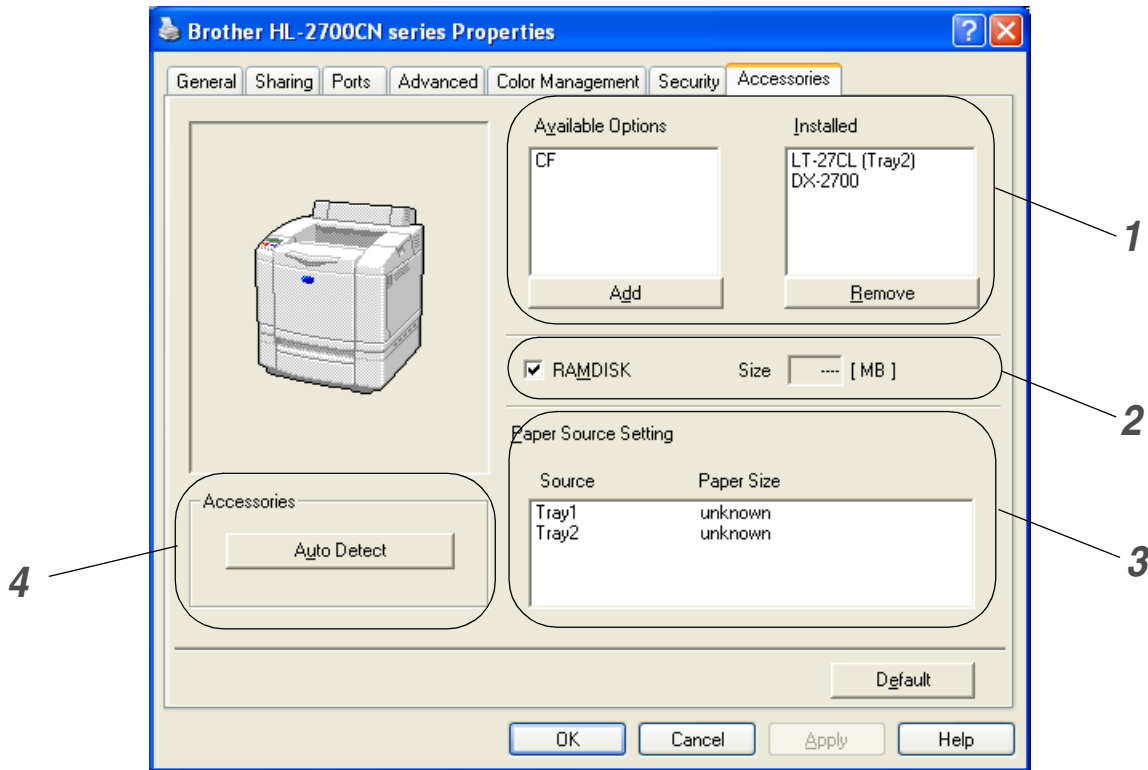

1 You can manually add or remove the options for any optional device that is installed on the printer. Tray settings will match the installed options.

2 RAMDISK

You can detect the capacity of RAMDISK that has been set using the control panel. To find the capacity of RAMDISK, tick the **RAMDISK** check box and then click **Auto Detect**.

For more information, see *Reprinting from RAM* on page 3-26.

3 Paper Source Setting

This feature recognizes the paper size in each paper tray.

4 Auto detection of printer options and RAMDISK

- The **Auto Detect** function finds the currently installed optional unit devices and shows the available settings in the printer driver. When you click the **Auto Detect** button, options that are installed on the printer will be listed. You can manually add or remove options.

 **Auto Detect** function may not be available under certain printer conditions.

Support Tab

 If you are using Windows NT® 4.0, Windows® 2000 or XP, you can access the **Support** tab by clicking **Printing Preferences...** in the **General** tab of the **Brother HL-2700CN series Properties** screen.

- You can download the latest driver by accessing the Brother Solutions Center at <http://solutions.brother.com>
- You can see the printer driver version.
- You can check the current driver settings.
- You can print the Print Settings page and internal fonts list.



Features in the PS printer driver

You can download the latest driver by accessing the Brother Solutions Center at <http://solutions.brother.com>

For more information, please see the online **Help** in the printer driver.

 The screens in this section are from Windows® XP. The screens on your PC will vary depending on your operating system.

Ports tab

Select the port where your printer is connected or the path to the network printer you are using.

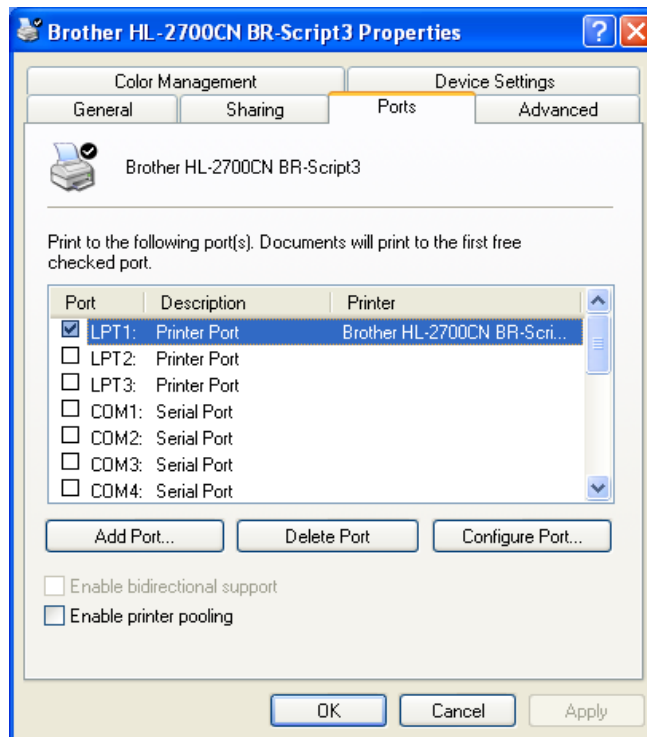

Device Settings tab

Select the options you installed.

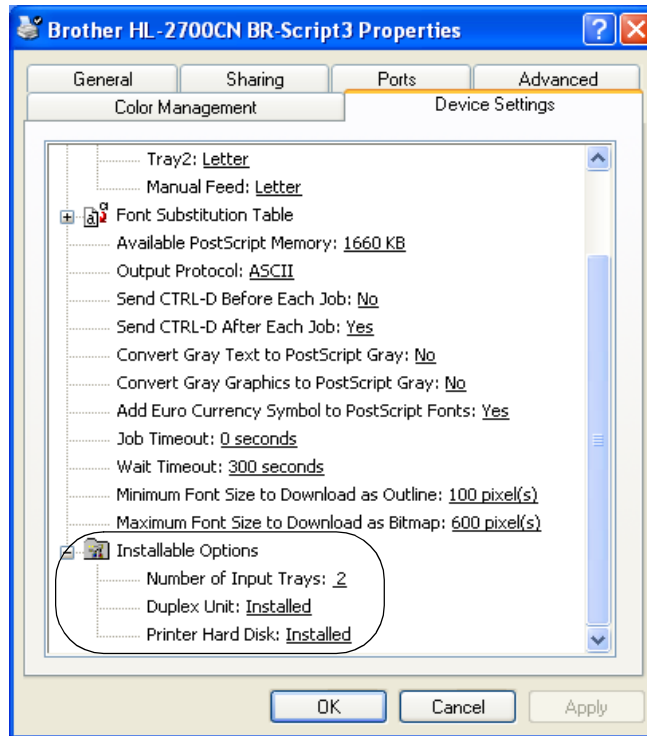

Layout tab

 If you are using Windows NT® 4.0, Windows® 2000 or XP, you can access the **Layout** tab by clicking **Printing Preferences...** in the **General** tab of the **Brother HL-2700CN BR-Script3 Properties** screen.

You can change the Layout setting by selecting the settings for **Orientation**, **Print on Both Sides (Duplex)**, **Page Order** and **Pages Per Sheet**:

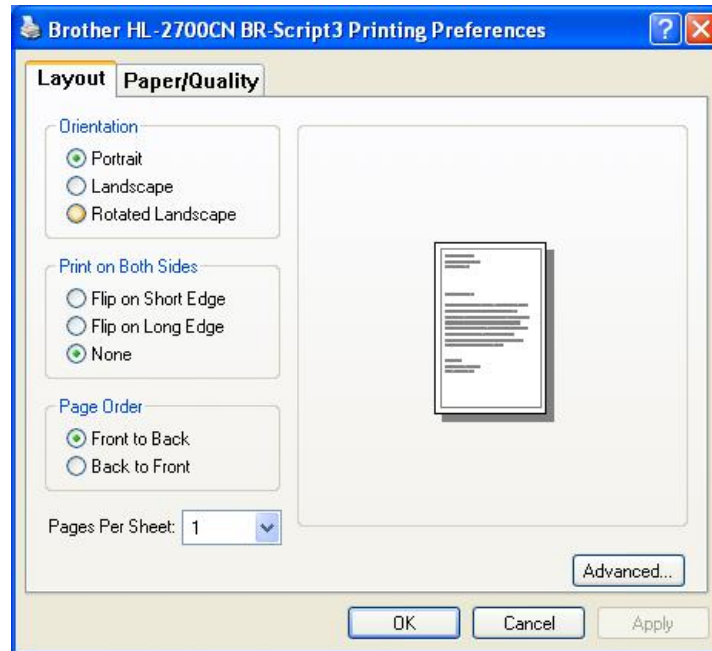

Paper / Quality tab

Select the **Paper Source** and **Color**.

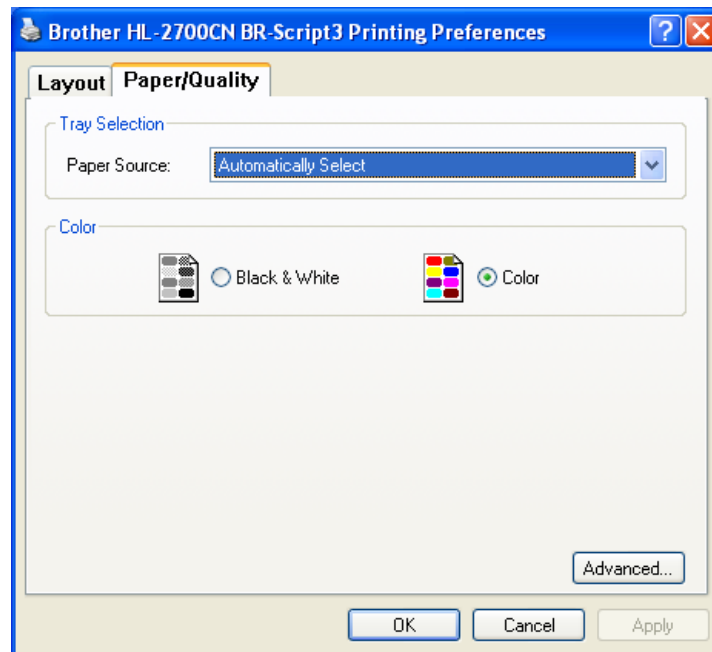

Advanced options

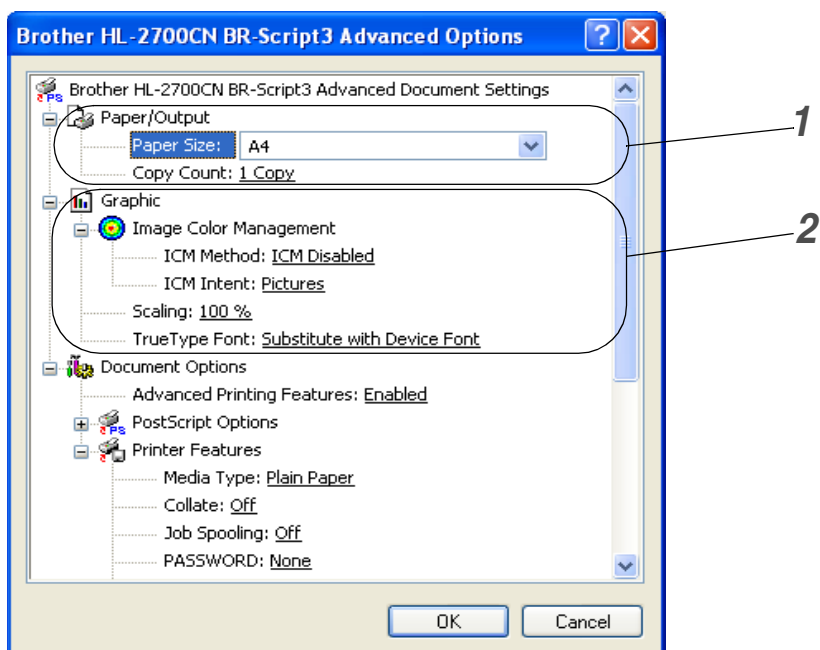

- 1 Select the **Paper Size** and **Copy Count**.
- 2 Set the **Image Color Management**, **Scaling** and **TrueType Font** settings.

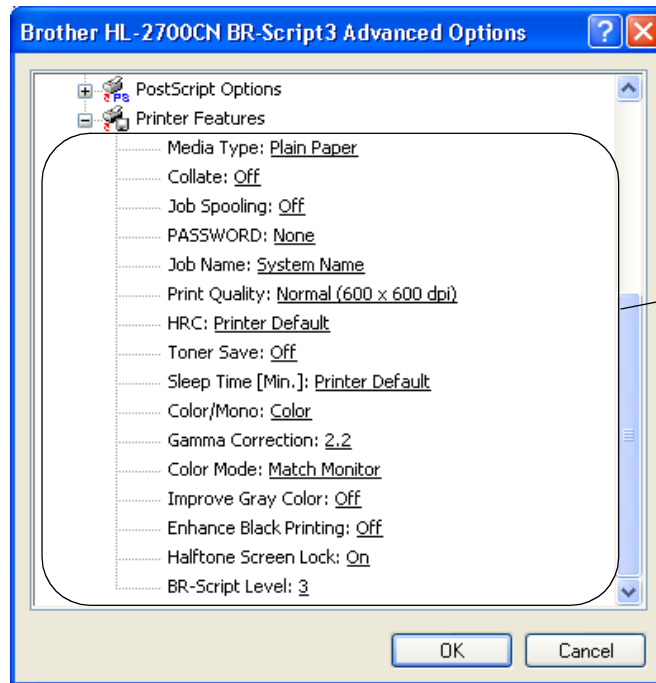

3 You can change settings by selecting the setting in the Printer Features list:

- Media Type
- Collate (Only when a CompactFlash® card is installed)
- Job Spooling
- PASSWORD
- Job Name
- Print Quality
- HRC
- Toner Save
- Sleep Time
- Color / Mono
- Gamma Correction
- Color Mode
- Improve Gray Color
- Enhance Black Printing
- Halftone Screen Lock
- BR-Script Level

For Macintosh®

This printer supports Mac OS® 8.6 to 9.2 and Mac OS® X 10.1 to 10.2.

You can download the latest driver by accessing the Brother Solutions Center at <http://solutions.brother.com>

 The screens in this section are from Mac OS® X 10.1. The screens on your Macintosh® will vary depending on your Operating System.

Page setup

You can set the **Paper Size**, **Orientation** and **Scale**.

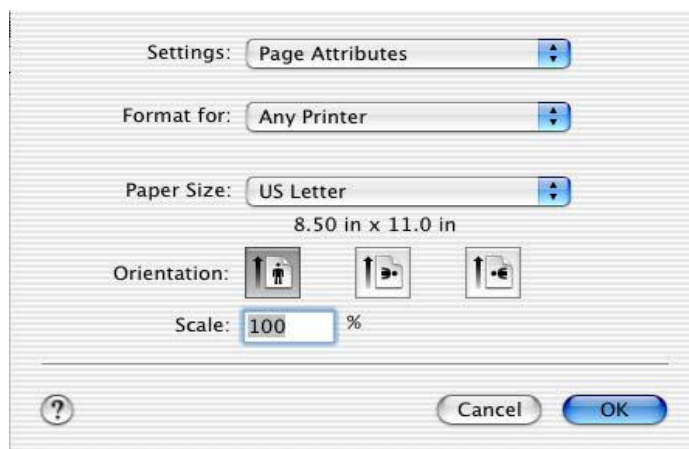

Layout

Set the **Layout**, **Pages per Sheet** and other settings.

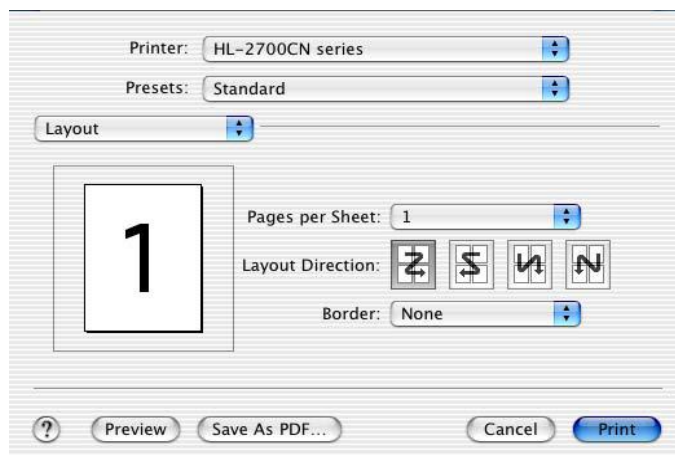

Specific settings

Set the **Media Type**, **Job Spooling**, **PASSWORD** and other settings.

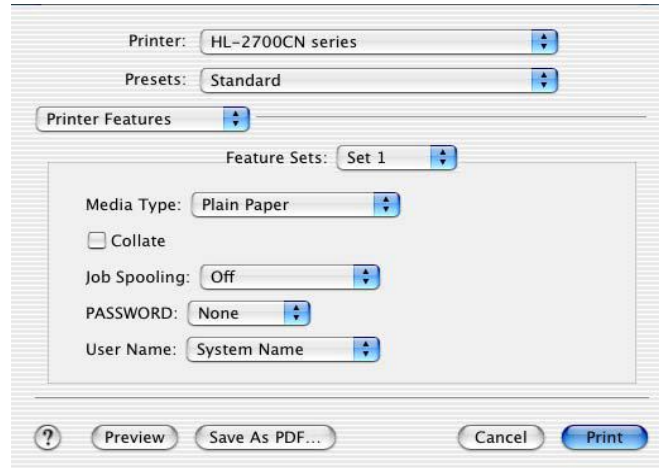

The image shows a printer settings dialog box for an HL-2700CN series printer. The dialog is titled "Printer: HL-2700CN series" and "Presets: Standard". Under the "Printer Features" section, the "Feature Sets" dropdown is set to "Set 1". The "Media Type" is set to "Plain Paper". There is an unchecked "Collate" checkbox. "Job Spooling" is set to "Off". "PASSWORD" is set to "None". "User Name" is set to "System Name". At the bottom, there are buttons for "?", "Preview", "Save As PDF...", "Cancel", and "Print".

Printer: HL-2700CN series

Presets: Standard

Printer Features

Feature Sets: Set 1

Media Type: Plain Paper

Collate

Job Spooling: Off

PASSWORD: None

User Name: System Name

? Preview Save As PDF... Cancel Print

Software



This section is for Windows®.

Software for Networks

BRAdmin Professional utility

The BRAdmin Professional is a utility for managing your Brother network enabled printers that are running under Windows® 95/98/Me, Windows NT® 4.0 and Windows® 2000/XP.

It allows you to easily configure and check the status of your printer on the network.

Driver Deployment Wizard

This installer includes the Windows® PCL driver and Brother network port driver (LPR and NetBIOS). The administrator should set up the IP address, Gateway and Subnet with BRAdmin Professional utility before using this software.

If the administrator then installs the printer driver and port driver using this software, he can save the file to the file server or send the file by E-mail to users. Then, each user just clicks that file to have the printer driver, port driver, IP address, and so on, automatically copied to their PC.

Web BRAdmin

The Web BRAdmin software is designed to manage all LAN/WAN Brother network connected devices. By installing the Web BRAdmin server software on a computer running IIS*, Administrators with a Web browser can connect to the Web BRAdmin server, which then communicates with the device itself. Unlike the BRAdmin Professional utility - which is designed for Windows® systems only - the Web BRAdmin server software can be accessed from any client computer with a web browser that supports Java 2.

You can download the Web BRAdmin software from our web site at <http://solutions.brother.com/webbradmin>

IIS* = Internet Information Server 4.0 or Internet Information Services 5.0/5.1

Web BRAdmin and Internet Information Server 4.0 is supported by the following operating systems:

- Windows NT® 4.0 Server

Web BRAdmin and Internet Information Server 5.0 is supported by the following operating systems:

- Windows® 2000 Professional
- Windows® 2000 Server
- Windows® 2000 Advanced Server

Web BRAdmin and Internet Information Server 5.1 is supported by the following operating systems:

- Windows® XP Professional

Automatic Emulation Selection

This printer has an Automatic Emulation Selection feature. When the printer receives data from the computer, it automatically chooses the emulation mode. This feature has been set at the factory to **ON**.

The printer can choose from the following combinations:

EPSON (default)	IBM
HP LaserJet	HP LaserJet
BR-Script3	BR-Script3
HP-GL	HP-GL
EPSON FX-850	IBM ProPrinter XL

To get the most out of this laser printer, we recommend that you use the Brother BR-Script3 emulation.

The printer is set to the HP color printer emulation (PCL 5C) mode automatically. Since PCL 5C mode takes the highest priority in the Automatic Emulation Selection, in most cases you can start using the printer as it is with the factory settings.



Emulation modes other than PCL 6, PCL 5C and BR-Script3 are monochrome emulation modes.

You can select the emulation mode manually by using the control panel to access **EMULATION** in the **SETUP** menu. See *SETUP* on page 3-12.



When you use the Automatic Emulation Selection, note the following:

- The EPSON or IBM emulation mode priority must be selected, because the printer cannot distinguish between them. Since the factory setting is EPSON emulation mode, you might need to select the IBM emulation mode by using the control panel to access **EMULATION** in the **SETUP** menu.
- Try Automatic Emulation Selection with your application software or network server. If it does not work properly, select the emulation mode manually by using either the printer control panel buttons or the emulation selection commands from your software.

Automatic Interface Selection

This printer has an Automatic Interface Selection feature. When the printer receives data from the computer, it automatically selects the IEEE 1284 Parallel or the USB interface, whichever is appropriate. When you use the parallel interface, you can turn the high-speed and bi-directional parallel communications on or off by using the control panel buttons to access **PARALLEL** in the **INTERFACE** menu. See *INTERFACE* on page 3-17. Since the Automatic Interface Selection mode has been factory set to **ON**, simply connect the interface cable to the printer. (Note: Always turn off both your computer and printer when connecting or disconnecting the cable).



When you use the Automatic Interface Selection, note the following:

- This function takes a few seconds to work. If you want to speed up printing, select the required interface manually by using the control panel to access **SELECT** in the **INTERFACE** menu.

If you typically use only one interface, we recommend that you select that interface in the **INTERFACE** mode. If only one interface is selected, the printer will allocate the entire input buffer to that interface.

Printer settings

Factory settings

The printer settings have been set at the factory before shipment. They are called factory settings. Although you can operate the printer with these factory settings unchanged, you can tailor the printer with user settings. See *List of factory settings* on page 3-22.



Changing the user settings does not affect the factory settings. You cannot modify the present factory settings.

The changed user settings can be restored to the default factory settings with the **RESET MENU** menu. See *RESET MENU* on page 3-17.

3 Control panel

Control panel

This printer has one liquid crystal display (LCD), six buttons and two Light Emitting Diodes (LEDs) on the control panel. The display can show various messages with up to 16 characters in each of the two rows. The LEDs light to indicate the current printer status.



Figure 3-1

Buttons

You can control the basic printer operations and change various printer settings with the six buttons (**Go**, **Job Cancel**, **+**, **-**, **Set**, **Back**).

Button		Operations
Go		Exit from the control panel menu, reprint settings, error messages and sleep mode.
Job Cancel		Stop and cancel the print job in progress.
Menu	+	Move forward through menus. Move forward through the options you can choose.
	-	Move backward through menus. Move backward through the options you can choose.
	Set	Select the control panel menu. Set the selected menus and settings.
	Back	Go back one level in the menu.

Go button

You can change the panel indications from the current status (Menu, Error and Reprint settings) by pressing the **Go** button once. For ERROR indications, the control panel only changes when the error is cleared.

You can pause printing with the **Go** button. Pressing the **Go** button again restarts the print job and clears the pause. During a pause, the printer is off-line.



If the printer is in PAUSE mode and you do not want to print the data that is left, you can cancel the job by pressing the **Job Cancel** button. Once the job has been canceled, the printer will return to the READY state.

Job Cancel button

You can cancel the processing or printing of data with the **Job Cancel** button. The display shows JOB CANCELLING until the job is cancelled. After cancelling the job, the printer returns to the READY state.

When the printer is not receiving data or printing, the display shows NO DATA!!! and you cannot cancel the job.

+ or - button

If you press the + or - button when the printer is in the on-line (Ready) state, it goes off-line and the LCD displays the menu.

To move through menus in the LCD

If you press the + or - button when the printer is in the on-line state, it goes off-line and the LCD displays the current mode.

You can go to other menus by pressing the + or - button. Pressing the + or - button allows you to move forward or backward through the menus and settings on the display. Press or keep pressing the button until you see the setting you want.

To enter numbers

You can enter numbers in two ways. You can press the + or - button to move up or down one number at a time, or you can hold down the + or - button to move faster. When you see the number you want, press the **Set** button.

Set button

If you press the **Set** button when the printer is in the on-line (Ready) state, it goes off-line and the LCD goes to the menu.

Pressing the **Set** button allows you to choose the displayed menu or option. After changing the setting, an asterisk (*) appears briefly on the right-hand side of the message.

Back button

If you press the **Back** button when the printer is in the on-line (Ready) state, it goes off-line and the LCD goes to the menu.

Pressing the **Back** allows you to return to the previous level from the current menu level.

The **Back** button also allows you to select the previous digit while setting numbers.

When you select the leftmost digit, the **Back** button allows you to go up one level in the menu.

When you select a setting and it does not have an asterisk (*) (**Set** button was not pressed), the **Back** button allows you to return to the previous menu level with the original setting unchanged.



When you press the **Set** button to choose a setting, an asterisk appears briefly at the end of the display. Since the asterisk shows what you have chosen, you can easily see the current settings as you look through the display.

Light-emitting diodes (LEDs)

The LED is a light that shows the printer status.

Status LED (Green)

LED indication	Meaning
On	Ready to print Printing Sleeping Data remains in the printer buffer (when DATA EXISTS shows on the LCD).
Blinking	Receiving or processing data
Off	Off-line

Alarm LED (Red)

LED indication	Meaning
On	There is an error in the printer.
Off	There is no error in the printer.

Liquid crystal display (LCD)

The display shows the current printer status. When you use the control panel buttons, the display will change.

If you take the printer off-line, the display changes to show the emulation you have chosen.

If there are any problems, the display shows the appropriate error message, maintenance message, or call service message so you will know that you need to take action. For more information about these messages, see *Troubleshooting* in Chapter 6.

LCD messages

The message on the LCD display shows the current printer status during normal operation as shown below.

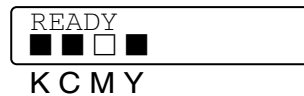

The ■ marks indicate the status of the toner in the toner cartridges (K: Black, C: Cyan, M: Magenta, Y: Yellow). When the ■ mark blinks (□), the indicated toner is nearly empty. When toner becomes empty, the ■ indicator disappears completely.

When an error has occurred, the type of error is displayed on the first line of the LCD message as shown below.

The message on the second line shows information for clearing the error as shown below.



Printer status messages

The following table shows the printer status messages that are displayed during normal operation:

Printer status message	Meaning
READY	Ready to print.
PRINTING	Printing.
RESOLUTION ADAPT	Printing with reduced resolution.
PROCESSING	Busy processing data.
JOB CANCELLING	Cancelling the job.
PAUSE	The printer has suspended its operations. Press the Go button to start the printer again.
WARMING UP	The printer is warming up.
SLEEP	In sleep status
PRESS SET TO PRINT	Press the Set button to start printing.
RESET TO FACTORY SETTING	The printer settings return to the factory settings.
SELF TEST	Performing self-diagnostics.
RAM SIZE=xxMB	This printer has XX MB memory.
NOW INITIALIZING	The printer is setting up.
PROGRAMING-WAIT	Accessing CompactFlash card.

How to use the control panel

When you use the **Menu** buttons (+, -, **Set** or **Back**), remember the following basic steps:

- If no control panel operations are performed for 30 seconds, the LCD automatically returns to Ready state.
- When you press the **Set** button to choose a setting, an asterisk appears briefly at the end of the display. After that, the display returns to the previous menu level.
- After changing the status or a setting, pressing the **Back** button before you press the **Set** button will cause the display to return to the previous menu level with the original settings unchanged.
- There are two ways to input numbers. You can press the + or - button to scroll up or down one number at a time, or you can hold down + or - to scroll faster. The blinking number is the one that you can change.

For example: If you only use Tray 1 to print from, change the SOURCE setting to TRAY1, as follows:

READY



--MENU--
INFORMATION



--MENU--
PAPER



PAPER
SOURCE



SOURCE
=AUTO *



SOURCE
=TRAY1



SOURCE
=TRAY1

Press any of the Menu buttons (+, -, **Set** or **Back**) to take the printer off-line.

Press the + or - button to move forward or backward through the menus until PAPER is displayed.

Press the **Set** button to move to the next menu level.

Press the **Set** button.

Press the + button.

Press the **Set** button.
An asterisk * briefly appears at the end of the display.
The default setting is indicated by an *.

Control panel LCD menu



The control panel LCD names for the paper trays are as follows:

- Standard paper tray: TRAY1
- Optional lower tray: TRAY2
- Optional duplex unit: DX

There are 9 menus. For more information about the selections available in each menu, please see the pages listed below:

INFORMATION

See *INFORMATION* on page 3-10.

PAPER

See *PAPER* on page 3-11.

QUALITY

See *QUALITY* on page 3-11.

SETUP

See *SETUP* on page 3-12.

PRINT MENU

See *PRINT MENU* on page 3-13.

NETWORK

See *NETWORK* on page 3-16.

INTERFACE

See *INTERFACE* on page 3-17.

RESET MENU

See *RESET MENU* on page 3-17.

REPRINT

See *REPRINT* on page 3-18.

INFORMATION

Display Shows	Description		
PRINT SETTINGS	Prints the print settings page.		
PRINT TEST	Prints the test page.		
PRINT DEMO	Prints the demonstration sheet.		
PRINT FILE LIST	Prints the card list.		
PRINT FONTS	Prints the fonts list and samples.		
VERSION	Subsetting	Description	
	SER.NO=#####	Shows Printer serial number.	
	ROM VER=####	Shows ROM version	
	ROM DATE YY/MM/DD	Shows ROM date	
	NET VER=####	Shows Network version	
	NET DATE YY/MM/DD	Shows Network build date	
	ENG VER=####	Shows Engine firmware version	
	RAM SIZE=###MB	Shows the size of memory in this printer.	
MAINTENANCE	PAGE COUNTER	=#####	Shows the current total printed pages.
	IMAGE COUNTERS	C=#####, M=#####, Y=#####, K=#####, TOTAL=#####	Shows the amount of images produced by an individual color and the combined Total of all 4 colors.
	REMAIN OPC BELT	=#####	Shows the remaining life for the OPC Belt, Fuser, 120K Kit and PF Kit2. See 5-2.
	REMAIN FUSER	=#####	
	REMAIN 120K KIT	=#####	
	REMAIN PF KIT2	=#####	

PAPER

Display Shows	Description
SOURCE	=AUTO/TRAY1/TRAY2 Selects which paper tray the paper will be fed from.
MANUAL FEED	=OFF/ON Selects whether or not you want to feed paper manually.
TRAY1 SMALL SIZE	=B5/DL/COM-10/JISB5
TRAY2 SMALL SIZE	=B5/JISB5
DUPLEX	=OFF/ON(LONG BIND)/ON(SHORT BIND) Selects whether you want to automatically print on both sides of the paper.

QUALITY

Display Shows	Description	
HRC	=MEDIUM/DARK/OFF/LIGHT HRC: High Resolution Control offers improved print quality of letters, numbers and graphics that conventional laser printers cannot achieve, with a resolution of 300 or 600 dpi.	
TONER SAVE	=OFF/ON	
CALIBRATION	Subsetting	Description
	CALIBRATE	Carry out calibration to revise the colors.
	RESET	Set the calibration parameters back to those set at the factory.

SETUP

Display Shows	Description	
LANGUAGE	= ENGLISH/FRANÇAIS /...	
PANEL CONTROL	Subsetting	Description
	BUTTON REPEAT	Set the time for the display message to change when holding the + or - button at intervals of: 0.2, 0.4, 0.6, 0.8, 1.0, 1.4, 1.8 or 2.0 seconds. The factory setting is 0.2.
	MESSAGE SCROLL	Set the time in seconds that an LCD message will scroll across the display. From level 1=0.2 to Level 10=2.0. The factory setting is Level 1.
POWER SAVE	=ON/OFF	
POWER SAVE TIME	=1:30:99 MIN	
AUTO CONTINUE	=OFF/ON	
LOCK PANEL	=OFF/ON Turns the lock panel settings ON/OFF.	
	PASS NO.=###	
REPRINT	=ON/OFF	
PAGE PROTECTION	=AUTO/OFF/LETTER/LEGAL/A4	
EMULATION	=AUTO(EPSON)/AUTO(IBM)/HP LASER JET/....	
KEEP PCL	=OFF/ON	
RAMDISK SIZE	=0/1/2/...MB	RESTART PRINTER?
DELETE STORAGE	Deletes the data on the CompactFlash card.	
	Subsetting	Description
	SECURE FILE	Selects the user name, job name and password.
	PUBLIC FILE	Selects the user name and job name.
	PROOF FILE	Selects the user name and job name.
	DATA ID (CF)	=####
	MACRO ID (CF)	=####
	FONT ID (CF)	=####
	XLSTREAM (CF)	=####
FORMAT (CF)	OK?	
TIME STYLE	=YY/MM/DD hh:mm*	
DATE & TIME	DISPLAY	YYYY/MM/DD hh:mm
	YEAR	=YYYY
	MONTH	=MM
	DAY	=DD
	HOUR	=hh
	MINUTE	=mm

PRINT MENU

Display Shows	Description	
MEDIA TYPE	=PLAIN PAPER/TRANSPARENCIES/THICK PAPER/THICKER PAPER/THIN PAPER	
COLOR PRINT	=ON/OFF	
PAPER	Sets cut sheet paper size to A4, EXECUTIVE, COM-10, DL, B5, JIS B5, LETTER, LEGAL, A5	
COPIES	You can check the total number of printed pages.	
	Shows the number of printed pages. (1:999)	
ORIENTATION	This printer can print pages in portrait or landscape orientation.	
	PORTRAIT or LANDSCAPE	
PRINT POSITION	This printer can be adjusted to align the page format.	
	Subsetting	Description
	X OFFSET=0	=-500:+500 Moves the print start position (at the top-left corner of pages) horizontally up to -500 (left) to +500 (right) dots in 300 dpi.
	Y OFFSET=0	=-500:+500 Moves the print start position (at the top-left corner of pages) vertically up to -500 (up) to +500 (down) dots in 300 dpi.
AUTO FF TIME	=OFF/1:99 (sec) Allows you to print the remaining data without pressing the Go button	
FF SUPPRESS	=OFF/ON Turns the feed suppress (PAUSE) setting ON or OFF.	

PRINT MENU (Continued)

Display Shows	Description	
HP LASERJET	FONT NO.	=I0000:#####
	FONT PITCH	=###.##
	SYMBOL SET	PC-8/... Sets the symbol set or the character set.
	TABLE PRINT	Print code table.
	AUTO LF	=OFF/ON ON: CR→CR+LF, OFF: CR→CR
	AUTO CR	=OFF/ON ON: LF→LF+CR, FF+CR, or VT→VT+CR OFF: LF→LF, FF→FF, or VT→VT
	AUTO WRAP	=OFF/ON Selects whether a line feed and carriage return will happen when the printer reaches the right margin.
	AUTO SKIP	=ON/OFF Selects whether a line feed and carriage return will happen when the printer position reaches the bottom margin.
	LEFT MARGIN	=##### Sets the left margin at column 0 to 126 columns at 10 cpi.
	RIGHT MARGIN	=##### Sets the right margin at column 10 to 136 columns at 10 cpi.
	TOP MARGIN	=##### Sets the top margin at a distance from the top edge of the paper: 0, 0.33, 0.5, 1.0, 1.5 or 2.0" The factory setting is 0.5
	BOTTOM MARGIN	=##### Sets the bottom margin at a distance from the bottom edge of the paper: 0, 0.33, 0.5, 1.0, 1.5 or 2.0" The factory setting is 0.33(None-HP), 0.5(HP)
	LINES	=##### Sets the number of lines on each page from 5 to 128 lines.

PRINT MENU (Continued)

Display Shows	Description	
EPSON FX-850	FONT NO.	=I0000:#####
	FONT PITCH	=###.##
	CHARACTER SET	PC-8/... Sets the symbol set or the character set.
	TABLE PRINT	Print code table.
	AUTO LF	=OFF/ON ON: CR→CR+LF OFF: CR→CR
	AUTO MASK	=OFF/ON
	LEFT MARGIN	Sets the left margin at column 0 to 126 columns at 10 cpi.
	RIGHT MARGIN	Sets the right margin at column 10 to 136 columns at 10 cpi.
	TOP MARGIN	Sets the top margin at a distance from the top edge of the paper: 0, 0.33, 0.5, 1.0, 1.5 or 2.0" The factory setting is 0.33
	BOTTOM MARGIN	Sets the bottom margin at a distance from the bottom edge of the paper: 0, 0.33, 0.5, 1.0, 1.5 or 2.0" The factory setting is 0.33
	LINES	Sets the number of lines on each page from 5 to 128 lines.
IBM PROPRINTER	FONT NO.	=I0000:#####
	FONT PITCH	=###.##
	CHARACTER SET	PC-8/... Sets the symbol set or the character set.
	TABLE PRINT	Prints code table.
	AUTO LF	=OFF/ON ON: CR→CR+LF, OFF: CR→CR
	AUTO CR	=OFF/ON
	AUTO MASK	=OFF/ON
	LEFT MARGIN	Sets the left margin at column 0 to 126 columns at 10 cpi.
	RIGHT MARGIN	Sets the right margin at column 10 to 136 columns at 10 cpi.
	TOP MARGIN	Sets the top margin at a distance from the top edge of the paper: 0, 0.33, 0.5, 1.0, 1.5 or 2.0" The factory setting is 0.33
	BOTTOM MARGIN	Sets the bottom margin at a distance from the bottom edge of the paper: 0, 0.33, 0.5, 1.0, 1.5 or 2.0" The factory setting is 0.33
	LINES	Sets the number of lines on each page from 5 to 128 lines.

PRINT MENU (Continued)

Display Shows	Description	
HP-GL	CHAR SET (STD)	=####
	CHAR SET (ALT)	=####
	PEN # SIZE	PEN 1 to 6 (Set size and gray percentage for the selected pen.)
	PEN # GRAY	PEN 1 to 6 15, 30, 45, 75, 90 or 100 % (# is the selected pen number)
BR-SCRIPT	ERROR PRINT	=OFF/ON
	CAPT	=OFF/ON CAPT: Color Advanced Photoscale Technology offers photographic fine gray scale on graphics.

NETWORK

Display Shows	Description	
TCP/IP	Subsetting	Description
	TCP/IP ENABLE	=ON/OFF
	IP ADDRESS=	###.###.###.###
	SUBNET MASK=	###.###.###.###
	GATEWAY=	###.###.###.###
	IP BOOT TRIES	=#
	IP METHOD	=AUTO/STATIC/RARP/BOOTP/DHCP
	APIPA	=ON/OFF
NETWARE	NETWARE ENABLE	=ON/OFF
	NET FRAME	=AUTO/8023/ENET/8022/SNAP
APPLETALK	=ON/OFF	
NETBEUI	=ON/OFF	
DLC/LLC	=ON/OFF	
NETBIOS/IP	=ON/OFF	
ENET	=AUTO/100B-FD/100B-HD/10B-FD/10B-HD	

INTERFACE

Display Shows	Description	
SELECT	=AUTO/USB/PARALLEL/NETWORK	
AUTO IF TIME	= 1:99 (sec) You need to set the time-out period for the auto interface selection.	
INPUT BUFFER	= Level1:15 Increases or decreases the input buffer capacity.	RESTART PRINTER?
PARALLEL	When using the parallel interface	
	Subsetting	Description
	HIGH SPEED	=ON/OFF Turns high-speed parallel communications on or off.
	BI-DIR	=ON/OFF Turns bi-directional parallel communications on or off.
USB2.0	HIGH SPEED	=ON/OFF Turns high-speed USB2.0 communications on or off.

RESET MENU

Display Shows	Description	
RESET PRINTER	Resets the printer and restores all printer settings (including command settings) to settings you have previously made with the control panel buttons.	
FACTORY RESET	Resets the printer and restores all printer default settings (including command settings) to the factory settings. See <i>List of factory settings</i> on page 3-22.	
PARTS LIFE	Subsetting	Description
	OPC BELT	Resets the OPC Belt parts life. Appears when you need to replace the OPC belt.
	FUSER UNIT	Resets the Fusing Unit parts life. Appears when you need to replace the Fusing unit.
	120K KIT	Resets the 120K Kit parts life. Appears when you need to replace the 120K Kit.
	PF KIT2	Resets the PF kit2 parts life. Appears when you need to replace the PF Kit2.

REPRINT

Display Shows	Description
COPIES = 1	Appears when the printer has reprint data but no PROOF, PUBLIC or SECURE data in the memory.
LAST JOB	COPIES = 1 Appears when the printer has reprint data and PROOF, PUBLIC or SECURE data in the memory.
PROOF FILE	XXX (User name), XXX (Job name), COPIES = 1 Appears when the printer has PROOF data in the memory.
PUBLIC FILE	XXX (User name), XXX (Job name), COPIES = 1 Appears when the printer has PUBLIC data in the memory.
SECURE FILE	XXX (User name), XXX (Job name), XXX (Pass word), COPIES = 1 Appears when the printer has SECURE data in the memory.

Set date and time

--MENU--
INFORMATION



--MENU--
SETUP



SETUP
DATE & TIME



DATE & TIME
YEAR



YEAR
=1999 *



YEAR
=2003



YEAR
=2003 *



DATE & TIME
YEAR



DATE & TIME
MONTH



DATE & TIME
2003/10/25 10:22

Press the **+** or **-** button until the **SETUP** menu appears (and to display each setting shown below).

Press the **Set** button, and then press the **+** or **-** button until **DATE & TIME** appears.

Press the **Set** button, and then press the **+** or **-** button until **YEAR** appears.

a) Press the **Set** button.

b) Press the **+** button until the correct year appears.

c) Press the **Set** button.

d) After a short time, the display changes.

e) Press the **Set** button.

Repeat processes 'a to e' until you have set the date & time.

Set IP address

```
--MENU--  
INFORMATION
```



```
--MENU--  
NETWORK
```



```
NETWORK  
TCP/IP
```



```
TCP/IP  
TCP/IP ENABLE
```



```
TCP/IP  
IP ADDRESS=
```



```
IP ADDRESS=  
192.0.0.192 *
```



```
IP ADDRESS=  
123.0.0.192
```



```
IP ADDRESS=  
123.45.67.89
```



```
IP ADDRESS=  
123.45.67.89 *
```

Press the **+** or **-** button until the **NETWORK** menu appears (and to display each setting shown below).

Press the **Set** button.

Press the **Set** button.

Press the **+** button.

Press the **Set** button.

The last digit in the first part of the number is blinking.
Press the **+** or **-** button to increase or decrease the number.
Press the **Set** button to go to the next number.

Repeat this process until you have set your IP address.

Press the **Set** button to complete the IP address.

An asterisk appears at the end of the display.

About emulation modes

This printer has the following emulation modes:

HP LaserJet mode

The HP LaserJet mode (or HP mode) is the emulation mode in which this printer supports the PCL 5C and PCL 6 language of the Hewlett-Packard LaserJet laser printer. Many software applications support this type of laser printer. Using this mode will allow your printer to operate at its best with those applications.

BR-Script3 mode

BR-Script is an original Brother page description language and a PostScript® language emulation interpreter. This printer supports level 3. The BR-Script interpreter of this printer allows you to control text and graphics on pages.

For technical information about PostScript® commands, see the following commercial manuals:

- Adobe Systems Incorporated. PostScript® Language Reference, third Edition. Addison-Wesley Publishing Company, Inc., 1999. ISBN: 0-201-37922-8
- Adobe Systems Incorporated. PostScript® Language Program Design. Addison-Wesley Publishing Company, Inc., 1988. ISBN: 0-201-14396-8
- Adobe Systems Incorporated. PostScript® Language Tutorial and Cookbook. Addison-Wesley Publishing Company, Inc., 1985. ISBN: 0-201-10179-3

HP-GL mode

The HP-GL mode is the emulation mode in which this printer supports the HP-GL of the Hewlett-Packard plotter model HP-7475A. Many graphics and CAD applications support this type of plotter. Use this mode so your printer will work well when printing from those types of applications.

EPSON FX-850 and IBM Proprinter XL mode

The EPSON FX-850 and IBM Proprinter XL modes are the emulation modes that this printer supports to meet the industry-standard for dot matrix printers. Some applications support these dot matrix printer emulations. Use these emulation modes so your printer will work well when printing from those types of applications.

List of factory settings

Table 1 shows the factory settings.



- Different emulation modes will have different factory settings.
- The following settings cannot be automatically restored to the factory settings by using the **FACTORY RESET** in the **RESET MENU** menu - **INTERFACE** menu, **HRC**, **PAGE PROTECTION**, **SCALABLE FONT**, **LOCK PANEL**, page counter and local language for display messages.
- The **COPY** setting is always restored to the factory setting when the printer is turned off and on.

Network factory default setting

If you wish to reset the print server back to its default factory settings (resetting all information such as the password and IP address information), please follow these steps:

- 1 Turn off the printer.
- 2 Hold down the + button as you turn on the power switch. Keep the button pressed down until the LCD display shows

--MENU--
INFORMATION
- 3 The print server has been reset to its default factory settings.

Table 1: List of factory settings

MODE	MENU	Factory Setting
PAPER	SOURCE	=AUTO
	MANUAL FEED	=OFF
	DUPLEX	=OFF
QUALITY	HRC	=MEDIUM
	TONER SAVE	=OFF
SETUP	LANGUAGE	=ENGLISH
	POWER SAVE TIME	=30MIN
	AUTO CONTINUE	=OFF
	LOCK PANEL	=OFF
	REPRINT	=ON
	PAGE PROTECTION	=AUTO
	EMULATION	=AUTO(EPSON)
	KEEP PCL	=OFF
	RAMDISK SIZE	=#MB
	TIME STYLE	=YY/MM/DD hh:mm
PRINT MENU	MEDIA TYPE	=PLAIN PAPER
	PAPER	=A4/LETTER
	COPIES	=1
	ORIENTATION	=PORTRAIT
	PRINT POSITION	X OFFSET=0 Y OFFSET=0
	AUTO FF TIME	=5
	FF SUPPRESS	=OFF
	HP LASERJET	FONT NO.=59
		FONT PITCH/POINT=10.00/12.00
		SYMBOL/CHARACTER SET=PC8
		AUTO LF=OFF
		AUTO CR=OFF
		AUTO WRAP=OFF
		AUTO SKIP=ON
		LEFT MARGIN=####
		RIGHT MARGIN=####
		TOP MARGIN=####
BOTTOM MARGIN=####		
LINES=####		

Table 1: List of factory settings (Continued)

MODE	MENU	Factory Setting
PRINT MENU	EPSON FX-850	FONT NO.=59
		FONT PITCH/POINT=10.00/12.00
		SYMBOL/CHARACTER SET=US ASCIF
		AUTO LF=OFF
		AUTO MASK=OFF
		LEFT MARGIN=####
		RIGHT MARGIN=####
		TOP MARGIN=####
		BOTTOM MARGIN=####
		LINES=####
	IBM PROPRINTER	FONT NO.=59
		FONT PITCH/POINT=10.00/12.00
		SYMBOL/CHARACTER SET=PC8
		AUTO LF=OFF
		AUTO CR=OFF
		LEFT MARGIN=####
		RIGHT MARGIN=####
		TOP MARGIN=####
		BOTTOM MARGIN=####
		LINES=####
	HP-GL	CHAR SET(STD)=####
		CHAR SET(ALT)=####
		PEN # SIZE
		PEN # GRAY
	BR-SCRIPT	ERROR PRINT=OFF
		CAPT=OFF

Table 1: List of factory settings (Continued)

MODE	MENU	Factory Setting
NETWORK	TCP/IP	TCP/IP ENABLE=ON
		IP ADDRESS=169.254.###.###
		SUBNET MASK=255.255.0.0
		GATEWAY=0.0.0.0
		IP BOOT TRIES=3
		IP METHOD=AUTO
		APIPA=ON
	NETWARE	NETWARE ENABLE=ON
		NET FRAME=AUTO
	APPLETALK	=ON
	NETBEUI	=ON
	DLC/LLC	=ON
	NETBIOS/IP	=ON
ENET	=AUTO	
INTERFACE	SELECT	=AUTO
	AUTO IF TIME	=5
	INPUT BUFFER	=LEVEL 3
	PARALLEL	HIGH SPEED=ON
		BI-DIR=ON
	USB2.0	HIGH SPEED=ON

 Automatic Private IP Addressing (APIPA) protocol, automatically configure an IP address and subnet mask. See the Network User's Guide, which is provided on the CD-ROM.

Reprint setting

If you want to reprint a document that has just been printed, you can reprint it by using the control panel button. Also, if you have created a document that you wish to share with colleagues, simply spool the document to a non-secure area of the printer. This document can then be reprinted by anyone who is on the network or at the printer control panel.

If you want to print PROOF, PUBLIC or SECURE data, we recommend that you install the optional CompactFlash® card.

Reprinting from RAM

If you do not install a CompactFlash® card (see *CompactFlash® card* on page 4-11), you can reprint from random access memory (RAM). The reprint data in RAM will be deleted when the printer is turned off.

When you use RAM to reprint:

- 1 Press the **Set** button on the control panel to exit from the READY state and select **RAMDISK SIZE** in the **SETUP** menu.
 - 2 The pre-set RAM disk is 0MB. Press the **+** button to increase the reprint RAM size in increments of 1MB.
-  ■ When you increase the RAM size for Secure Printing, the work area of the printer is decreased and the printer performance will be reduced. Make sure that you reset the **RAMDISK SIZE** to 0MB after you finish using Secure Printing.
 - You can also save macros, the print log, and fonts on RAMDISK.
 - When you store data in RAM, the data will be deleted when the printer is turned off.

We recommend that you add more RAM if you want to be able to print a lot of secured data. (See *SO-DIMM* on page 4-13)

Reprinting the last job

You can reprint the data from the last print job without sending it from the computer again.



- If you want to cancel reprinting, press the **Job Cancel** button.
- If the printer does not have enough memory to spool the print job data, it will print only the last page. We recommend that you expand the memory when you want to reprint a large amount of data. For more information on memory expansion, see *SO-DIMM memory* on page 4-1.
- For information about the settings in the printer driver, see *Job Spooling* on page 2-6.

Reprint the last job three times

1 Turn the REPRINT setting ON by using the control panel buttons to go to the **SETUP** menu.



If you print using the driver we have supplied with the printer, the settings for Job Spooling in the printer driver will take priority over the settings made on the control panel. See *Job Spooling* on page 2-6.

2

--MENU--
INFORMATION



--MENU--
REPRINT



--REPRINT--
COPIES= 1

Press the **+** or **-** button until the **REPRINT** menu appears (and to display each setting shown below).

Press the **Set** button.

If **PROOF**, **PUBLIC** or **SECURE** data exists.

---REPRINT---
LAST JOB

←
Press the **Set** button.



--REPRINT--
COPIES= 3

Press the **+** button twice.



PRINTING

Press the **Set** button.



--REPRINT--
COPIES= 1



- Pressing the + or - button makes the number of reprint copies decrease or increase. You can select between 1 and 999 COPIES.
- If you wait 30 seconds to continue the control panel operation, the display leaves the **REPRINT** setting automatically.
- If you press the **Go** button twice, the printer will leave the **REPRINT** setting.
- If you want to reprint the data and have pressed the **Go** button, the display shows `PRESS SET TO PRINT`. Press the **Set** button to start reprinting, or press **Go** again to leave the **REPRINT** setting.
- If the printer does not have reprint data in the memory and you press the **Set** button when the printer is in the **REPRINT** menu, the LCD shows `NO DATA STORED`.

Printing PROOF data

You can use this setting to reprint PROOF data that has just been printed and has no security settings. Documents that are placed in the PROOF area are available to anyone. You might use this setting for a document that will be moved to a public folder at a later date.

When the area to spool data is full, the earliest data is automatically deleted first. The order of deleting data is not connected to the order of reprinting.

When you reprint PROOF data, please see *How to print SECURE data* on page 3-30.



- If you have not installed the optional CompactFlash®, the reprint data will be deleted when the printer is turned off.
- If there is data in the job information that cannot be displayed on the LCD, the display shows a ?.
- For more information about the settings in the printer driver, see *Job Spooling* on page 2-6.

Printing PUBLIC data

You can use this setting to reprint documents that are stored in a PUBLIC area of the printer memory. Documents here will not be protected by a password and anyone can access them using the control panel or a web browser. The printer will not print a PUBLIC document when you send it to the printer. You must use the control panel of the printer or connect to the printer through a web browser.

PUBLIC data can be deleted using the control panel of the printer or from the web-based management software.

When you reprint PUBLIC data, please see *How to print SECURE data* on page 3-30.



- If there is data in the job information that cannot be displayed on the LCD, the display shows a ?.
- For more information about the settings in the printer driver, see *Job Spooling* on page 2-6.

Printing SECURE data

SECURE documents are protected by a password and only those people who know the password will be able to print the document. The printer will not print the document when you send it for printing. To print the document you must use the control panel of the printer (with the password) or connect to the printer using a web browser.

If you want to delete the spooled data, you can carry out this operation using the control panel or the web-based management software.



- If there is data in the job information that cannot be displayed on the LCD, the display shows a ?.
- For more information about the settings in the printer driver, see *Job Spooling* on page 2-6.

How to print SECURE data

```
--MENU--  
INFORMATION
```



```
--MENU--  
REPRINT
```



```
--REPRINT--  
SECURE FILE
```



```
SECURE FILE  
USER XXXXXXX
```



```
USER XXXXXXX  
JOB XXXXXXX
```



```
JOB XXXXXXX  
PASSWORD= 0000
```



```
--REPRINT--  
COPIES= 1
```



```
PRINTING
```

Press the **+** or **-** button until the **REPRINT** menu appears (and to display each setting shown below).

Press the **+** or **-** button.

Press the **Set** button.

Press the **+** or **-** to select the user name.
Press the **Set** button to set the user name.

Press the **+** or **-** to select the job.
Press the **Set** button to set the job.

Type your password.
Press the **Set** button to set the password



The printer will exit this menu after a time-out period.

Press the **Set** button.
If you press the **Go** button, the display shows PRESS SET TO PRINT.

When there is no reprint data in memory

If the printer does not have reprint data in the memory and you press the **Set** button when the printer is in the **REPRINT** menu, the LCD shows `NO DATA STORED`.

To delete the job

Using the control panel button, select the **DELETE STORAGE** submenu under the **SETUP** menu. Select the user name and the job to delete it (you will need to enter the password to delete secure data).

To cancel the reprint job

Pressing the **Job Cancel** button allows you to cancel the current reprint job. **Job Cancel** also allows you to cancel a paused reprint job.

4 Options

Optional accessories and supplies

This printer has the following optional accessories. You can increase the capabilities of the printer with these items.

Lower tray unit (LT-27CL)

See *Lower tray unit (LT-27CL)* on page 4-2.

Legal tray (LT-27LG)

See *Legal tray (LT-27LG)* on page 4-5.

Duplex unit (DX-2700)

See *Duplex unit (DX-2700)* on page 4-7.

CompactFlash® card

See *CompactFlash® card* on page 4-11.

SO-DIMM memory

See *SO-DIMM* on page 4-13.

Optional fonts package

See *Optional fonts package* on page 4-16.

Lower tray unit (LT-27CL)

The lower tray unit (Tray 2) is an optional device that can hold up to 530 sheets of extra paper (75 g/m² or 20 lb). You can put Letter, A4, B5 (JIS and ISO) or Executive size (176x250 to 215.9x297mm) paper in this tray. If you want to buy the optional lower tray unit, call the dealer you bought the printer from.

Putting paper in the lower tray unit

After you have installed the lower paper tray, you can put paper in it the same way you put paper in the upper paper tray.

How to install the lower tray unit

- ▲ ■ This printer is heavy and weighs approximately 31.5 kg (69.4 lb). To prevent injuries, use at least two people to lift the printer.
- When you lift the printer make sure you use the handholds at the bottom four corners of the printer.
- When placing the printer on top of the lower tray unit, be careful not to catch your fingers between them.
- Do not carry the printer when the lower tray unit and/or the duplex unit are attached.

! Caution

When moving or lifting this printer, keep the printer flat. To avoid spills, you must first remove the toner cartridges and waste toner pack.

- 1 Turn off the printer power switch and unplug the printer.
- 2 Place the lower tray unit on a flat table, and then remove the protective parts.

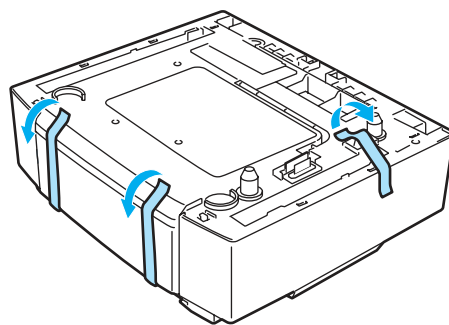

Figure 4-1

- 3** Remove the paper tray from the lower tray unit.

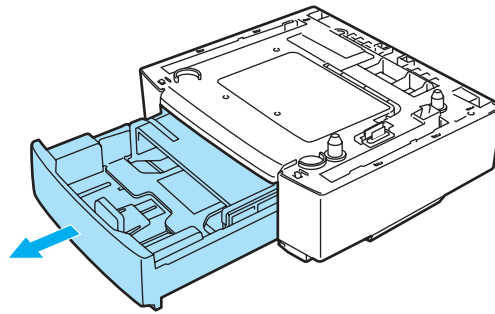

Figure 4-2

- 4** Remove the protective parts and then put the paper tray back in the lower tray unit.

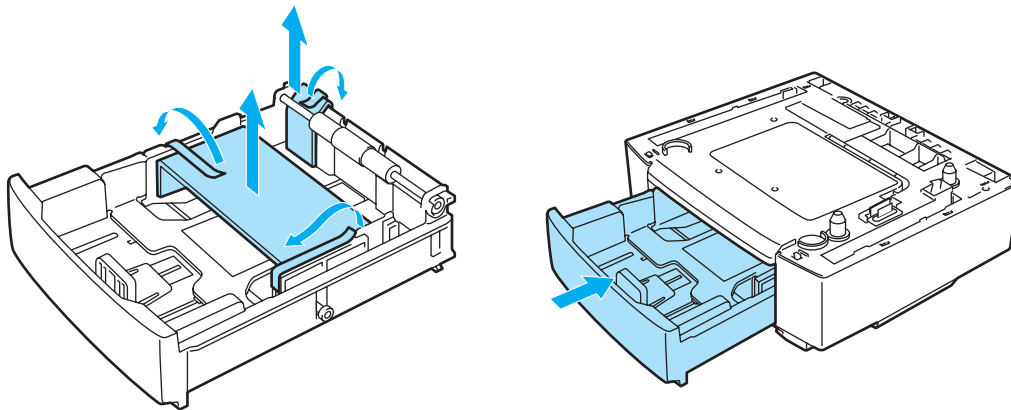

Figure 4-3

- 5** Check the two alignment pins on the lower tray unit. Use two people to lift the printer and place it on top of the lower tray unit. Make sure you use the handholds at the bottom four corners of the printer. Check that the pins are properly inserted into the printer. Check that the connector is inserted.

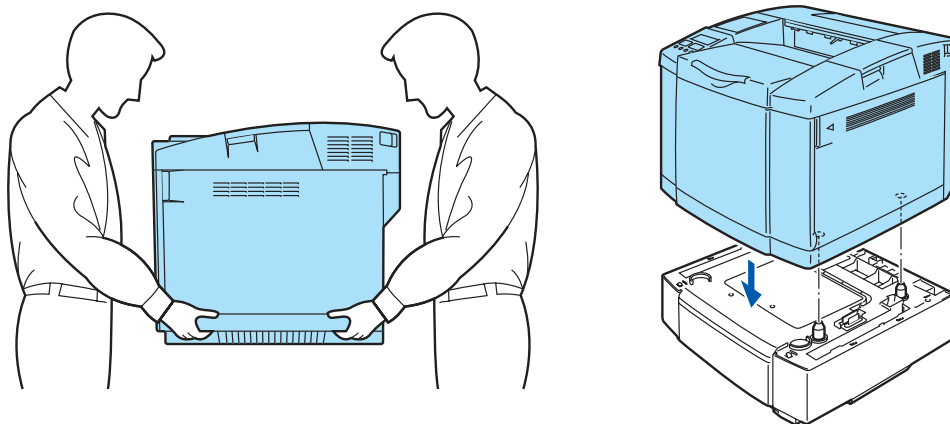

Figure 4-4

- 6 Fit the two stopper fittings on the right and left hand sides of the lower tray unit.

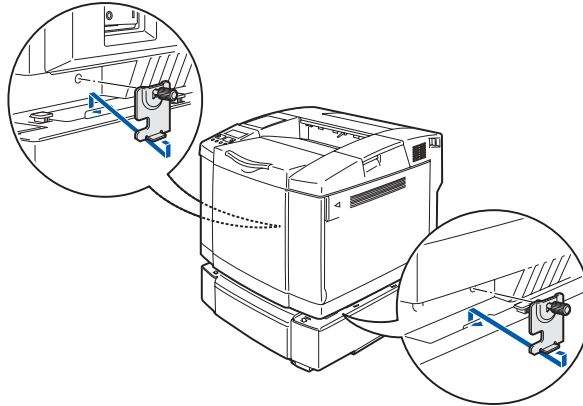

Figure 4-5

- 7 Cover the gap on the right hand side with the right-hand side cover by first inserting the hook at the back. Cover the gap on the left hand side with the left-hand side cover by first inserting the hook at the back.

Close both of the side covers by putting the notch over the hook of the lower tray unit.

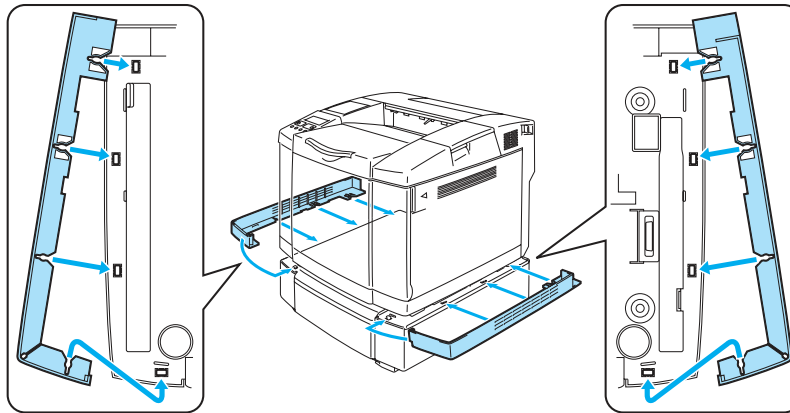

Figure 4-6

- 8 To level the printer, adjust the feet of the lower tray unit at the front and back on the right-hand side. Turn the feet to move them up or down until they touch the work surface and the tray unit is level. Turn the lock screw on each foot to secure it.

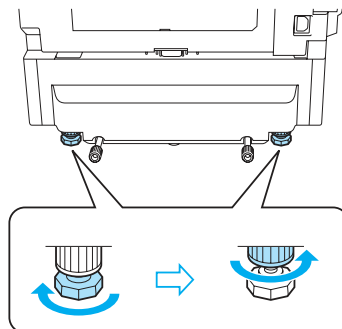



Figure 4-7

 Do not put transparencies, labels or envelopes in the paper tray of the optional lower tray unit. This might cause paper jams.

Legal tray (LT-27LG)

If you wish to print on Legal size paper, you must use the Legal tray. However, since it is not restricted to Legal size paper, you can choose to load Letter, A4, B5 (JIS/ISO), Executive, A5 or envelopes in this tray. If you want to buy the optional legal tray, call the dealer you bought the printer from.

How to install the legal tray

⚠ When you lift the printer make sure you use the handholds at the bottom four corners of the printer.

! **Caution**

When moving or lifting this printer, keep the printer flat. To avoid spills, you must first remove the toner cartridges and waste toner pack.

- 1 Pull out the standard paper tray.

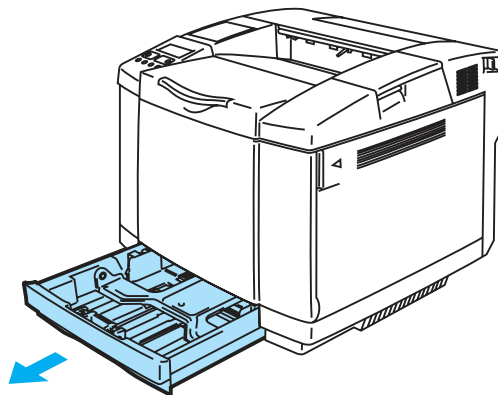

Figure 4-8

- 2 Place the legal tray on a flat table and lift the front tray cover.

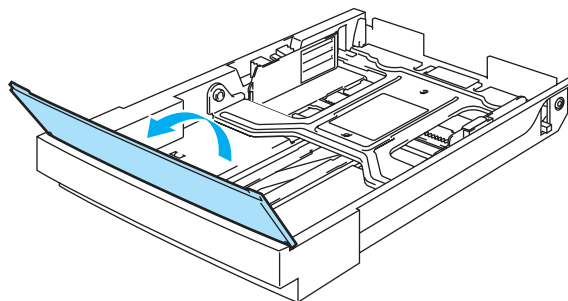

Figure 4-9

- 3** Squeeze the snap lock on the end of the front paper guide. Slide the front paper guide to the position for the size of paper you are using. Release the snap lock. Squeeze and slide the left hand side paper guide to the paper size you are using, and release it.

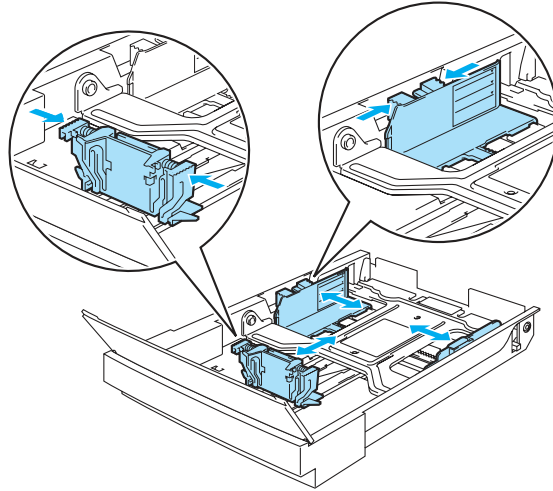

Figure 4-10

- 4** Put the paper in the tray with the recommended print side face up.

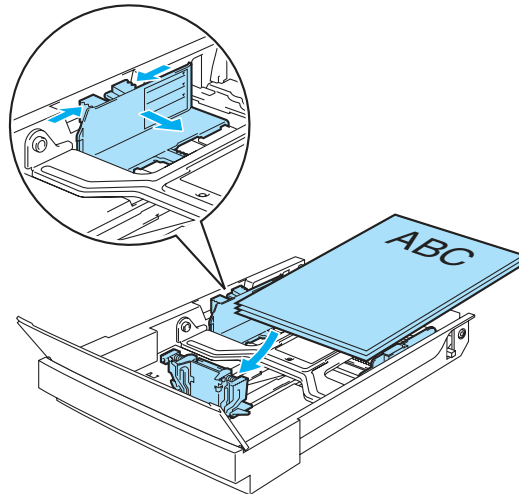

Figure 4-11

- 5** Lower the front tray cover.

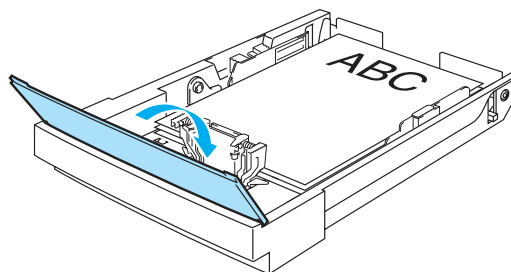

Figure 4-12

- 6** Slide the paper tray back into the printer.

Duplex unit (DX-2700)

The duplex unit is an optional device that allows you to print on both sides of a piece of paper. You can print on Letter, A4, B5 (JIS/ISO), Executive, A5 and Legal size paper. When it is installed, you can select either duplex printing or simplex printing on the control panel or with a software command. See *PAPER* on page 3-11 for details about the menu setting.

How to install the duplex unit

- ▲ ■ This printer is heavy and weighs approximately 31.5 kg (69.4 lb). To prevent injuries, use at least two people to lift the printer.
- When you lift the printer, be sure to use the handholds at the bottom four corners of the printer.
- Do not carry the printer when the lower tray unit and/or the duplex unit are attached.

! Caution

When moving or lifting this printer, keep the printer flat. To avoid spills, you must first remove the toner cartridges and waste toner pack.

- 1 Turn off the printer power switch and unplug the printer.
- 2 Remove the duplex upper cover, duplex lower cover and duplex cap at the back of the printer. We recommend removing the covers and the cap with a coin or a screwdriver.

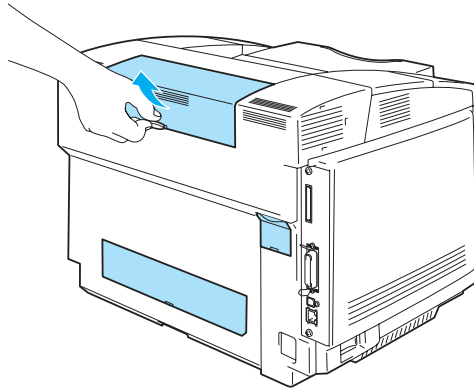

Figure 4-13

- 3 Remove the protective parts.

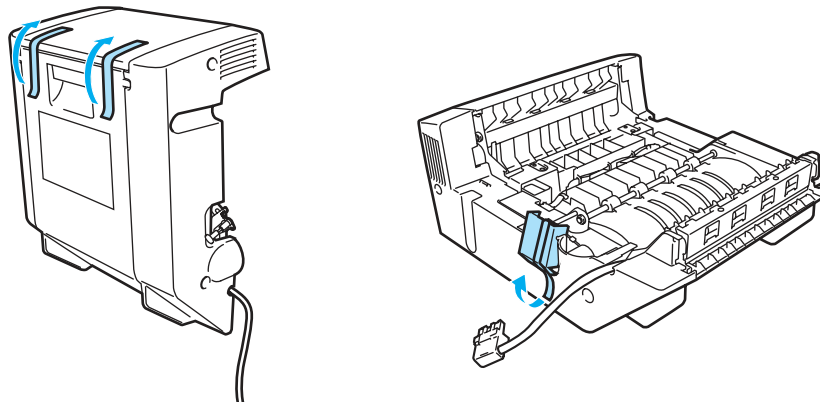

Figure 4-14

4 Use the handholds of the duplex unit to lift it up.

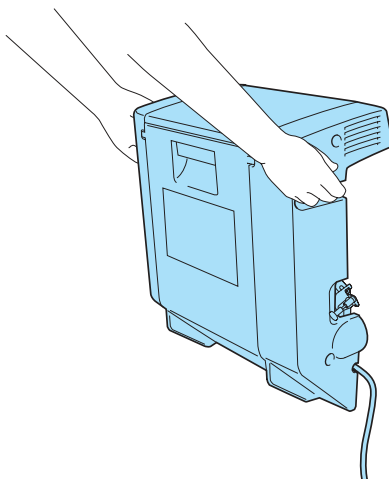

Figure 4-15

5 Insert the bottom of the duplex unit into the grooves in the printer, and then insert both the hooks of the duplex unit to the holes of the printer.

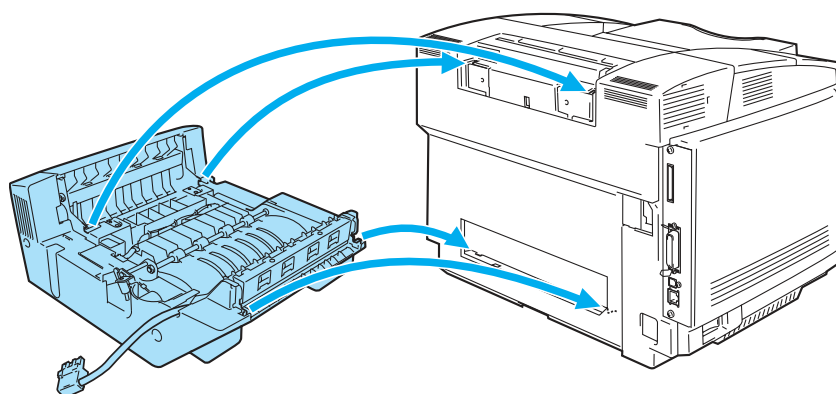

Figure 4-16

6 Open the duplex back cover and duplex inside unit.

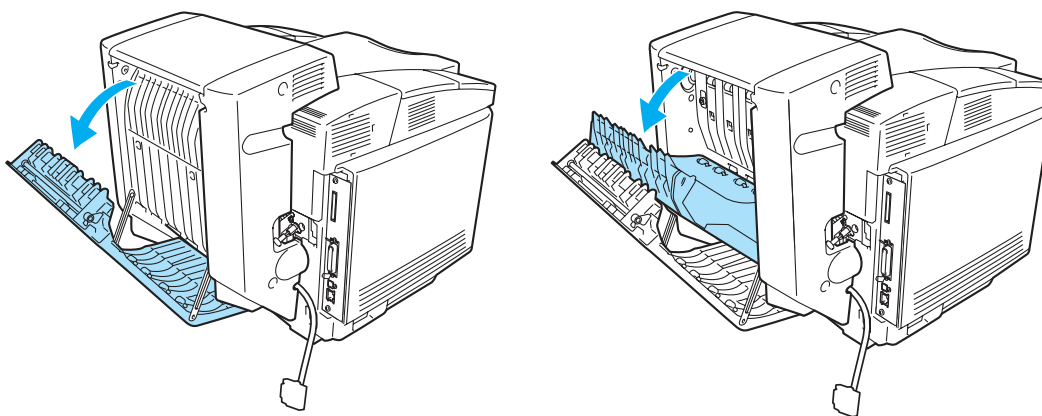

Figure 4-17

- 7** Pull out the 2 green sleeves covering the screws as far as they will come. Turn the green sleeves to tighten the screws of the duplex unit to the printer. Once the screws are fully tight, push the green sleeves back in.

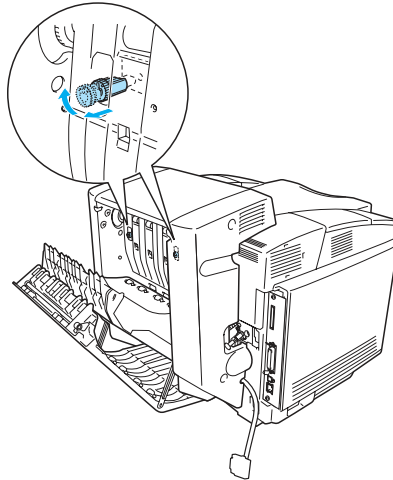

Figure 4-18

- 8** Put the hook on the left hand side of the duplex unit into the hole of the printer. Secure the screw of the duplex unit to the printer.

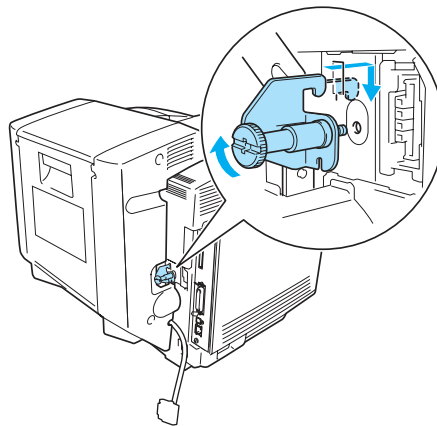

Figure 4-19

- 9** Connect the connector cable to the printer.

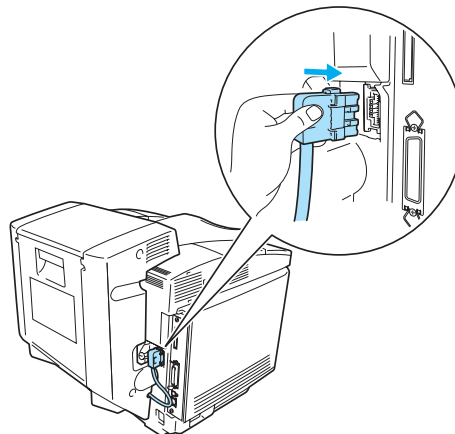

Figure 4-20

- 10** Plug the printer into the AC power outlet/socket and turn on the printer power switch.

Guidelines for printing on both sides of the paper



- If the paper is thin, it may wrinkle.
- If paper is curled, straighten it and place it in the paper tray.
- If the paper is not feeding properly, it may be curled. Remove the paper and straighten it.

Paper orientation for printing on both sides of the paper

The printer prints the second page first. If you print 10 pages on 5 sheets of paper, it will print page 2 followed by page 1 on the first sheet of paper.

It will print page 4 followed by page 3 on the second sheet of paper. It will print page 6 followed by page 5 on the third sheet of paper, and so on.

For duplex printing, you must put the paper in the paper tray in the following way:

Put the side to be printed on first, face down, with the leading edge (top) of the paper at the back of the tray. If letterhead paper is used, put it in the paper tray with the heading face up, and at the back of the tray.

CompactFlash® card

This printer has a slot for an optional CompactFlash® card. If you install an optional CompactFlash® card, you can save macros, the print log, and fonts on it. You can also select your print job and reprint it through the network.



- Make sure the printer power is OFF before you insert or remove the card, this is so you don't seriously damage it or lose all its data.
- For more information about the CompactFlash® card, call the dealer you bought the printer from.
- For the latest information visit: <http://solutions.brother.com>

You can install the following types of CompactFlash® memory cards:

SanDisk (or SanDisk OEM products)

Type II

- 32 MB SDCFB-32-801
- 64 MB SDCFB-64-801
- 96 MB SDCFB-96-801
- 128 MB SDCFB-128-801
- 192 MB SDCFB-192-801
- 256 MB SDCFB-256-801



- Make sure the printer power is off before you install or remove a card so you don't seriously damage it or lose all its data.
- IBM Microdrive™ is not compatible.
- For more information about the card, call the dealer you bought the printer from.

Inserting the CompactFlash® card

Follow these steps to insert or remove a card:

- 1** Turn off the printer power switch, and then unplug the printer. Disconnect the interface cable from the printer.
- 2** Insert the CompactFlash® card into the slot with the label facing to the left, press the card firmly into the slot.

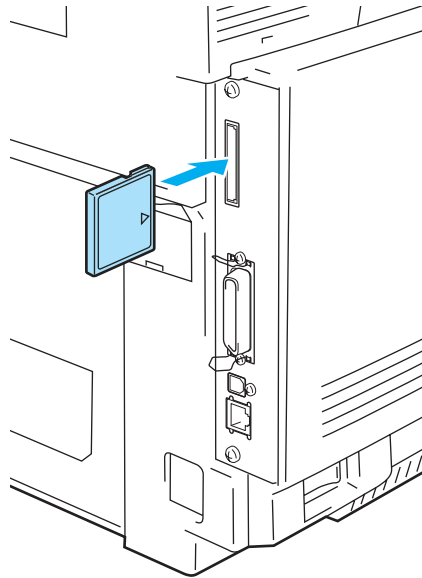

Figure 4-21

SO-DIMM

We recommend that you expand the printer memory to avoid any MEMORY FULL errors.

The HL-2700CN printer has 64 MB of standard memory and a slot for optional additional memory. The memory can be expanded up to a total of 576 MB by installing a commercially available SO-DIMM (Dual In-line Memory Module).

The printer uses memory modules that are:

144 pins, no-parity, SDRAM with 64 MB or more.

The printer is not compatible with Extended Data Output (EDO) DIMM.

The following SO-DIMM sizes can be installed:

<US>

■ 64 MB	TechWorks	12345-0001
■ 128 MB	TechWorks	12462-0001
■ 256 MB	TechWorks	12469-0001

<Europe>

■ 64 MB	Buffalo Technology	VN133-64M
■ 128 MB	Buffalo Technology	VN133-128M
■ 256 MB	Buffalo Technology	VN133-256M
■ 512 MB	Buffalo Technology	VN133-512M



For more information, visit Techworks web site at www.techworks.com

In general, SO-DIMM must have the following specifications:

Type:	144 pin and 64 bit output
CAS latency:	2 or 3
Clock frequency:	100 MHz or more
Capacity:	64 MB to 512 MB
DRAM type:	SDRAM



- The printer's standard memory can vary depending on the printer model and the country.
- There might be some SO-DIMMs that will not work with this printer.
- For more information, call the dealer you bought the printer from or Brother Customer Service.
- For the latest information, visit the Brother Solutions Center at <http://solutions.brother.com>

Installing additional memory

- 1 Turn off the printer power switch, and then unplug the printer. Disconnect the interface cable from the printer.

Caution

Make sure you turn the printer OFF before you install or remove the SO-DIMM. Installing optional accessories without turning off the printer could result in electric shock hazard.

- 2 Unscrew the two screws securing the back plate of the main controller board, and then pull out the main controller board.

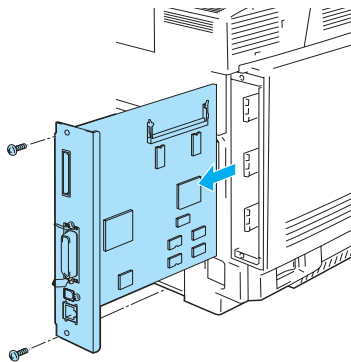

Figure 4-22

- 3 Unpack the SO-DIMM and hold it by the edges.

Caution

SO-DIMM boards can be damaged by even a small amount of static electricity. Do not touch the memory chips or the board surface. Wear an antistatic wrist strap when you install or remove the board. If you do not have an antistatic wrist strap, keep touching the bare metal on the printer.

- 4 Hold the SO-DIMM with your fingers on the side edges and align the notch in the SO-DIMM with the protrusions in the SO-DIMM slot.

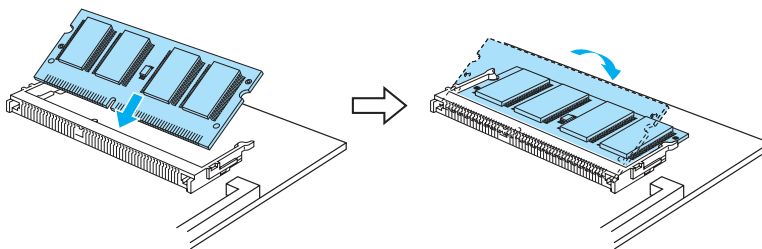



Figure 4-23

- 5 Put the SO-DIMM diagonally, and then tilt the SO-DIMM toward the main controller board until it clicks into place.

 To remove the SO-DIMM, open the retaining clips on both sides of the SO-DIMM by pushing them outward, grasp both edges of the SO-DIMM and pull it out straight.

- 6 Put the main controller board back into the printer by sliding it into the guide rails.

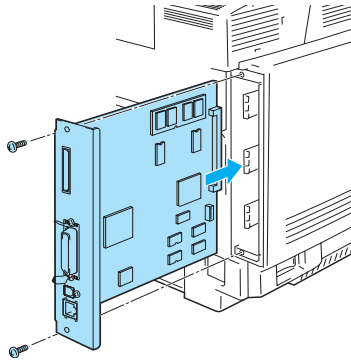



Figure 4-24

- 7 Put the metal plate back on and secure the metal plate with the two screws.
 - 8 Reconnect the interface cable (printer cable) to your computer. Plug the printer back in, and then turn on the printer power switch.
-  To check that you have installed the SO-DIMM properly, you can print the Print Settings listing that shows the current memory size. To print the Print Settings listing, see *PRINT SETTINGS* on page 3-10.

Optional fonts package

Optional fonts package (BS-3000)

The optional fonts package (BS-3000) is the CD-ROM you need for installing the PS3 136 compatible fonts.

Optional barcode fonts package (BT-1000)

The optional barcode fonts package (BT-1000) is the CD-ROM you need for installing the barcode fonts.

Selecting the optional fonts

After you have installed the optional font card, you can select optional fonts using any of the following methods:

- 1 Through your application software
- 2 With a font selection command
- 3 With the control panel menu settings.

When you select fonts through your application software, follow the instructions specific to your software. See your software manual if you need assistance. When you select fonts with a font selection command, embed the font selection command in your program. See the *Technical Reference Manual*. Call a Brother authorized service representative or Brother Customer Service for references to the *Technical Reference Manual*.



When you select the fonts through your software or with a command, note the following:

- You do not need to be concerned about the font control panel setting. The software or command overrides the printer setting.
- Be sure to install a font package that has the fonts you want. The printer automatically selects the font that has exactly the same or similar characteristics as those you have set through the software or with a command. If the installed font package does not happen to have a font of similar characteristics, the printer will print in an unexpected font.

To select fonts with the control panel setting menu, follow these basic steps:

- 1 Press any of the **Menu** buttons (+, -, **Set** or **Back**) to take the printer off line.
- 2 Press + or - until **INFORMATION** appears on the LCD display.
- 3 Press **Set** to proceed to the next menu level, and then press + or - until **PRINT FONTS** appears.
- 4 Press **Set** to print the list of optional fonts (Figure 4-23).
- 5 Find the font number on the list.

Font number

NUMBER		SYMBOL SET		INTERNAL FONT		
(10)	WIDTH	SIZE	STYLE	HEIGHT	TYPEFACE	F O N T S A M P L E (660pp)
1000	10U:PC-B...	Pi Scalable	Upright(0)	Medium(0)	PETERMEX REG (4101)	ABCDefgh1234567890!"#\$%&'()*+,-./
		ESC(Z)ESC(1)P0=034101T			(#point size 0.25 - 999.75)	
1005	10U:PC-B...	Pi Scalable	Upright(0)	Bold(2)	PETERMEX BI (4101)	ABCDefgh1234567890!"#\$%&'()*+,-./
		ESC(Z)ESC(1)P0=034101T			(#point size 0.25 - 999.75)	
1002	10U:PC-B...	Pi Scalable	Italic(1)	Medium(0)	PETERMEX It (4101)	ABCDefgh1234567890!"#\$%&'()*+,-./
		ESC(Z)ESC(1)P0=034101T			(#point size 0.25 - 999.75)	
1003	10U:PC-B...	Pi Scalable	Fixed(1)	Bold(2)	PETERMEX BIIt (4101)	ABCDefgh1234567890!"#\$%&'()*+,-./
		ESC(Z)ESC(1)P0=034101T			(#point size 0.25 - 999.75)	
1004	10U:PC-B...	Pi Scalable	Upright(0)	Medium(0)	DELAMON REG (4113)	ABCDefgh1234567890!"#\$%&'()*+,-./
		ESC(Z)ESC(1)P0=034113T			(#point size 0.25 - 999.75)	
1005	10U:PC-B...	Pi Scalable	Upright(0)	Medium(0)	DELAMON BI (4113)	ABCDefgh1234567890!"#\$%&'()*+,-./
		ESC(Z)ESC(1)P0=034113T			(#point size 0.25 - 999.75)	
1006	10U:PC-B...	Pi Scalable	Italic(1)	Medium(0)	DELAMON It (4113)	ABCDefgh1234567890!"#\$%&'()*+,-./
		ESC(Z)ESC(1)P0=034113T			(#point size 0.25 - 999.75)	
1007	10U:PC-B...	Pi Scalable	Italic(1)	Bold(2)	DELAMON BIIt (4113)	ABCDefgh1234567890!"#\$%&'()*+,-./
		ESC(Z)ESC(1)P0=034113T			(#point size 0.25 - 999.75)	
1008	10U:PC-B...	Pi Scalable	Fixed(1)	Medium(0)	CONNECTICUT (4116)	ABCDefgh1234567890!"#\$%&'()*+,-./
		ESC(Z)ESC(1)P0=1A04116T			(#point size 0.25 - 999.75)	
1009	10U:PC-B...	Pi Scalable	Upright(4)	Bold(2)	CLEVELAND CO (4140)	ABCDefgh1234567890!"#\$%&'()*+,-./
		ESC(Z)ESC(1)P0=034116T			(#point size 0.25 - 999.75)	
1010	10U:PC-B...	Pi Scalable	Upright(4)	Light(-3)	ROUSSSEL LY (4142)	ABCDefgh1234567890!"#\$%&'()*+,-./
		ESC(Z)ESC(1)P0=034143T			(#point size 0.25 - 999.75)	
1011	10U:PC-B...	Pi Scalable	Fixed(2)	Bold(2)	ROUSSSEL BI (4143)	ABCDefgh1234567890!"#\$%&'()*+,-./
		ESC(Z)ESC(1)P0=034143T			(#point size 0.25 - 999.75)	
1012	10U:PC-B...	Pi Scalable	Fixed(1)	Light(-3)	ROUSSSEL LYIt (4143)	ABCDefgh1234567890!"#\$%&'()*+,-./
		ESC(Z)ESC(1)P0=034143T			(#point size 0.25 - 999.75)	
1013	10U:PC-B...	Pi Scalable	Fixed(1)	Bold(2)	ROUSSSEL BIIt (4143)	ABCDefgh1234567890!"#\$%&'()*+,-./
		ESC(Z)ESC(1)P0=034143T			(#point size 0.25 - 999.75)	
1014	10U:PC-B...	Pi Scalable	Upright(0)	Medium(0)	UTAH REG (4148)	ABCDefgh1234567890!"#\$%&'()*+,-./
		ESC(Z)ESC(1)P0=034148T			(#point size 0.25 - 999.75)	
1015	10U:PC-B...	Pi Scalable	Upright(0)	Bold(2)	UTAH BI (4148)	ABCDefgh1234567890!"#\$%&'()*+,-./
		ESC(Z)ESC(1)P0=034148T			(#point size 0.25 - 999.75)	
1016	10U:PC-B...	Pi Scalable	Italic(1)	Medium(0)	UTAH It (4148)	ABCDefgh1234567890!"#\$%&'()*+,-./
		ESC(Z)ESC(1)P0=034148T			(#point size 0.25 - 999.75)	
1017	10U:PC-B...	Pi Scalable	Fixed(1)	Bold(2)	UTAH BIIt (4148)	ABCDefgh1234567890!"#\$%&'()*+,-./
		ESC(Z)ESC(1)P0=034148T			(#point size 0.25 - 999.75)	

Figure 4-25

- 6 Press + or - on the control panel to select **PRINT MENU**.
- 7 Press **Set** to proceed to the next menu level, and then press + or - to select HP LASERJET, EPSON FX-850, or IBM PROPRINTER.
- 8 Press the **Set** button to select the emulation for the fonts you want to select HP LASERJET, EPSON FX-850, or IBM PROPRINTER.
- 9 Press + or - button to select FONT NO, and then select the font number of the font you want.

5 Routine maintenance



Replacing the consumable items

You will need to replace the following consumable items regularly. When the time comes to replace consumable items, the following messages will appear on the LCD panel.

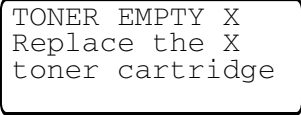
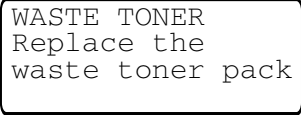
The printer will stop printing when the following maintenance messages appear on the LCD panel.

LCD messages	Consumable item to replace	Approximate life	How to replace	Order No.
	Toner cartridge C = Cyan, M = Magenta, Y = Yellow, K = Black	10,000 pages (Black) 6,600 pages (Cyan, Magenta, Yellow) *1	See 5-4	TN-04BK TN-04C TN-04M TN-04Y
	Waste toner pack	12,000 images *1 *3	See 5-8	WT-4CL

The following are maintenance messages that appear on the LCD panel in the READY state. These messages provide advanced warnings to replace the consumable items before they run out. To avoid any inconvenience, you may wish to buy spare consumable items before the printer stops printing.

LCD message	Consumable part to replace	Approximate life	How to replace	Order No.
	Toner cartridge, Black	10,000 pages *1 *2	See 5-4	TN-04BK
	Toner cartridge, Cyan, Magenta or Yellow	6,600 pages *1 *2	See 5-4	TN-04C TN-04M TN-04Y

The following are maintenance messages that appear alternatively with the **READY** message on the upper row of the LCD when the printer is in the **READY** state. These messages advise you that you will need to replace each of the consumable items as soon as possible, since the consumable item's end of life has been reached. The printer will continue printing when any of these messages appear on the LCD panel.

LCD messages	Consumable part to replace	Approximate life	How to replace	Order No.
NEAR WASTE TONER	Waste toner pack	12,000 Images	See 5-8	WT-4CL
REPLACE OPC BELT	OPC belt cartridge	60,000 images *3 (Continuously printed)	See 5-10	OP-4CL
REPLACE FUSER	Fusing unit	60,000 pages *1	See 5-13	FP-4CL
REPLACE 120 KIT	Transfer belt cleaner Transfer roller	120,000 pages	See 5-16	
	Paper pick-up roller Separator pad Transfer belt		Call your dealer or Brother Customer Service for a replacement of the paper pick-up roller and separator pad.	
REPLACE PF KIT2	Paper feeding kit 2. (Paper pick-up roller Separator pad)		Call your dealer or Brother Customer Service for a replacement of the paper feeding kit 2.	

*1 at 5 % coverage print (A4 or Letter size).



The toner cartridges that come supplied with this printer, are starter toners.

Starter toners, are toner cartridges with up to half the life of the standard toner cartridge, 5000 pages (Black) and 3000 pages (Cyan, Magenta and Yellow) at approximately 5% print coverage (A4 or Letter size).

*2 For example, if the Cyan and Magenta toner cartridges are almost empty, the indication will be

“ ■ □ □ ■ “ (□ = blinking ■)

K C M Y

If the Cyan and Magenta toner cartridges are empty, the ■ indicator will have disappeared.

*3 Definition of pages: actual output page number.

Definition of images:

If the image on a page contains only one color of either Cyan, Magenta, Yellow or Black =>1 image, two colors => 2 images, three colors => 3 images, four colors => 4 images.



- Discard the used consumable item according to local regulations, keeping it separate from domestic waste. If you have questions, call your local waste disposal office. Be sure to re-seal the consumable item tightly so that the material inside does not spill.
- We recommend placing used consumable items on a piece of paper or cloth to prevent accidentally spilling or scattering the material inside.



- If you use paper that is not a direct equivalent for the recommended paper, the life of consumable items and printer parts may be reduced.
- The projected life for each of the items listed is based on an average of 5% coverage of the printable area using any color toner cartridge. Frequency of replacement will vary depending on the complexity of printed pages, percentage of coverage and type of media used.

Toner cartridges

A new toner cartridge contains enough toner to print up to 10,000 pages for Black and up to 6,600 pages for Cyan, Magenta and Yellow A4 or Letter-size single-sided pages at about 5% coverage.



- The amount of toner used varies depending on how much print is on the page and the print density setting.
- If you change the print density setting for lighter or darker printing, the amount of toner that is used will change.
- Wait to unpack the toner cartridge until immediately before you install it in the printer.

Toner nearly empty message

Check printed pages, page counter, and display messages regularly. If the  indicator starts blinking, the printer has nearly run out of toner or the toner is not evenly distributed inside the cartridge.

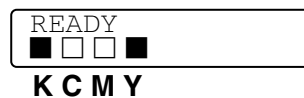

*K stands for Black, C stands for Cyan, M stands for Magenta and Y stands for Yellow.

Although you can print up to 300 (Black) and 500 (Cyan, Magenta and Yellow) additional pages (at 5% coverage) after the **TONER LOW** message first appears, be sure to replace the toner cartridge with a new one before it becomes completely empty. When this occurs, the  indicator on the LCD panel will disappear.

TONER EMPTY message

When the following message appears on the LCD panel and the printer stops printing, you need to replace the toner cartridge:

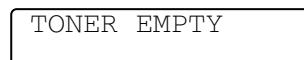

Replacing the toner cartridges

 Do not put the toner cartridge into a fire. It could explode.

 ■ Brother strongly recommends that you do not refill the toner cartridge provided with your printer. We also strongly recommend that you continue to use only Genuine Brother Brand replacement toner cartridges. Using or attempting to use potentially incompatible toner and /or toner cartridges in your printer may cause damage to the printer itself and/or it may result in unsatisfactory print quality. Our warranty coverage does not apply to any problem that was caused by the use of unauthorized third party toner and toner cartridges. To protect your investment and guarantee your print quality please continue to replace consumed toner cartridges with only Genuine Brother Branded Supplies.

■ Printing with a third-party toner or third-party toner cartridges may reduce not only the print quality but also the quality and life of the printer itself. It may also cause serious damage to the performance and life of a drum unit. Warranty coverage does not apply to problems caused by the use of third-party toner or third-party toner cartridges.

 We recommend that you clean the printer when you replace the toner cartridge. See *Cleaning* on page 5-21.

To replace the toner cartridge, follow these steps:

1 Open the front cover of the printer.

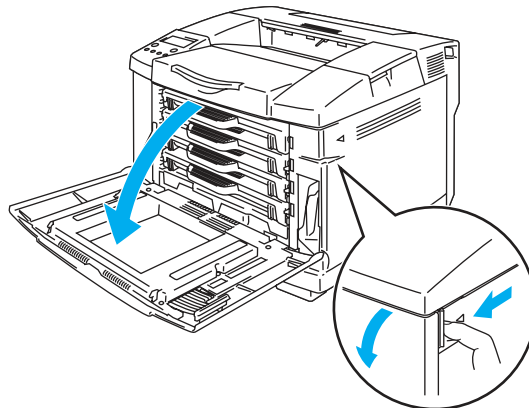



Figure 5-1

2 Pull out the used toner cartridge.

3 Take the new toner cartridge out of the box.

 Handle the toner cartridge carefully. If toner scatters on your hands or clothes, immediately wipe or wash it off with cold water.

 ■ Be sure to seal up the toner cartridge tightly so that toner powder does not spill out of the cartridge.

■ Discard the used toner cartridge according to local regulations, keeping it separate from domestic waste. If you have questions, call your local waste disposal office.

- 4** Hold the cartridge level with both hands and gently rock it from side to side three to four times to spread the toner evenly inside the cartridge. Remove the tape labeled REMOVE and the orange protective cover from the new toner cartridge.

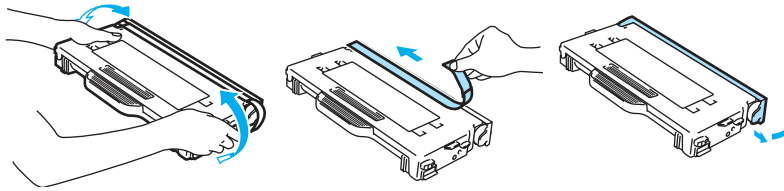

Figure 5-2

- **!** Wait to unpack the toner cartridge until immediately before you put it in the printer. If toner cartridges are left unpacked for a long time, the toner life will be shortened.
- Put the toner cartridge into the printer immediately after you have removed the protective cover. To prevent degradation to the print quality, do not touch the shaded parts shown in Figure 5-3.

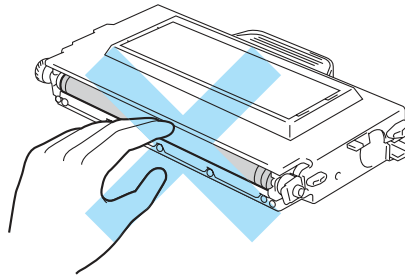

Figure 5-3

- 5** Put in the new toner cartridge by positioning it in the guide. Slide it gently into the printer. Do not try to push or lock the new toner cartridge in; it must rest loosely in the guide rails and will automatically be properly positioned when the front cover is closed. Note that each color cartridge is individually keyed to prevent improper installation. Match each cartridge color label to the same color label on the printer.

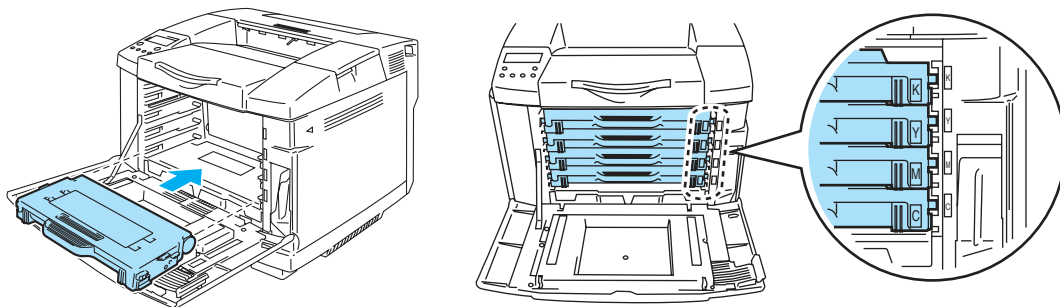

Figure 5-4

- 6** Close the front cover.



- Slide the toner cartridges into the printer *gently*. Do not try to lock them into the printer by pushing them. They must stay loosely in the guide rails so they will be properly positioned when the front cover is closed.
- If you use consumable items other than genuine Brother supplies or if you use refilled toner cartridges, the printer could be damaged or might not work properly. This may void your warranty.
- Do not stand a toner cartridge on its end or turn it upside down.

Waste toner pack

After you have printed approximately 12,000 images at 5% coverage, you must change the waste toner pack.

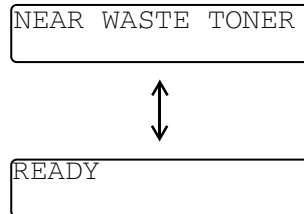

Waste toner pack full message

When the waste toner pack is full, the following message appears on the LCD and the printer will stop printing. When you see this message, you must replace the waste toner pack:

A rectangular box representing the LCD message. It contains the text "WASTE TONER" on the first line and "Replace the waste toner" on the second line.

 Do not re-use the waste toner pack.

Replacing the waste toner pack

- ⚠ ■ Do not put the waste toner pack into a fire. It could explode.
- Be careful not to spill the toner. Do not inhale or allow it to get into your eyes.
- ! Handle the waste toner pack carefully. If toner scatters on your hands or clothes, immediately wipe or wash it off with cold water.

- 1 Open the front cover of the printer.

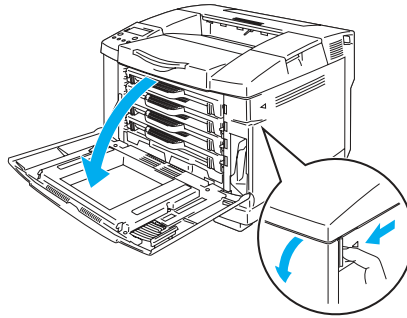

Figure 5-5

- 2 Remove the waste toner pack from the holder at the lower right hand side of the printer. Be careful not to spill the toner.

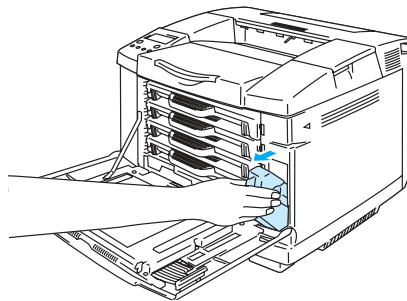

Figure 5-6

- 3 Take the cap off the new waste toner pack, and put the cap on the used waste toner pack.

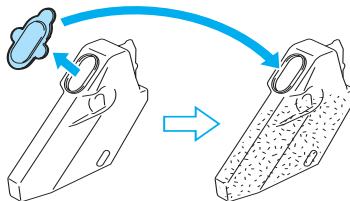

Figure 5-7

- When you discard the used waste toner pack, place it in the plastic bag included with the replacement waste toner pack.
- Discard the used waste toner pack according to local regulations, keeping it separate from domestic waste. If you have questions, call your local waste disposal office.

- 4 Put the new waste toner pack into the waste toner pack holder.

- 5 Close the front cover.

OPC belt cartridge

Replace OPC belt cartridge message

When the OPC belt cartridge runs out, the following message appears on the LCD. When you see this message, you must replace the OPC belt cartridge:

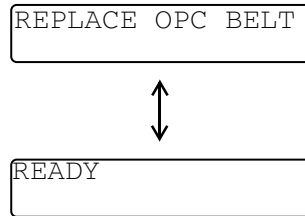

- ❗ ■ Do not touch the surface of the OPC belt cartridge. If you touch it, it could degrade print quality.
- Do not expose the OPC belt cartridge to light (more than 800 lux) for more than 2 minutes. This could degrade print quality.
- Damage caused by improper handling of the OPC belt cartridge may void your warranty.

Replacing the OPC belt cartridge

- 1 Turn off the printer power switch.
- 2 Open the top cover of the printer.

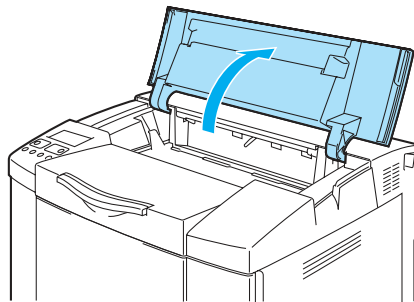

Figure 5-8

- 3 To release the lock, push the green belt cartridge lock levers on both sides inwards.

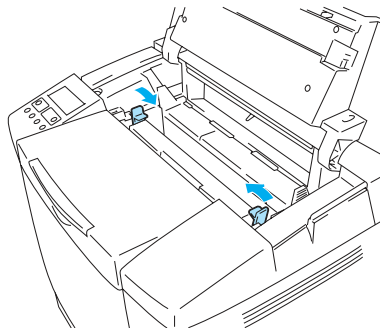

Figure 5-9

- 4 Remove the OPC belt cartridge from the printer.

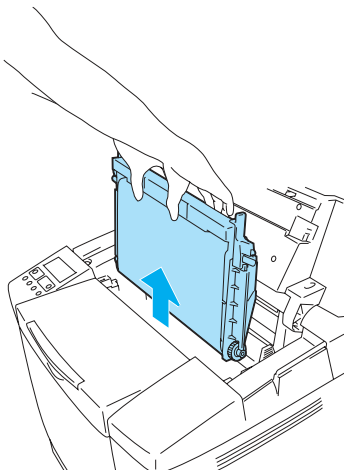

Figure 5-10

- 5 Remove the tension release pins from both sides of the new OPC belt cartridge.

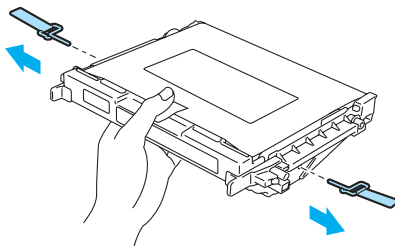

Figure 5-11

- 6 Remove the protective sheet from the new OPC belt cartridge. Do not touch the green part of the OPC belt cartridge.

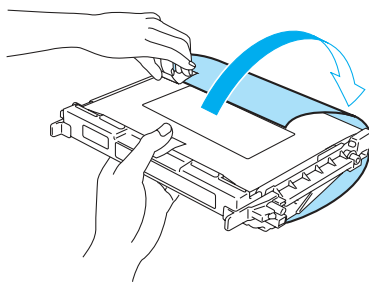

Figure 5-12

- 7 Put the new OPC belt cartridge into the printer guides with the flat side facing you.

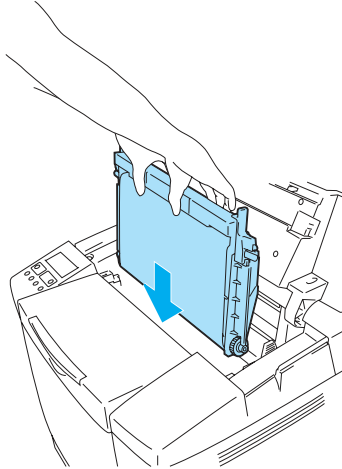

Figure 5-13

- 8 To lock the cartridge into the printer, push the belt cartridge lock levers that are on both sides of the OPC belt cartridge outwards.
- 9 Close the top cover.
- 10 Turn the printer power switch back on.
- 11 Press any of the **Menu** buttons (+, –, **Set** or **Back**) to take the printer off line.
- 12 Press + or – until `RESET MENU` appears.
- 13 Press **Set** to proceed to the next menu level, and then press + or – until `PARTS LIFE` appears.
- 14 Press **Set**, and then press + until `OPC BELT` appears.
- 15 Press **Set**. The printer is now in the `READY` state.

Fusing unit

Replace fusing unit message

When the following message appears on the LCD panel, you must replace the fusing unit.

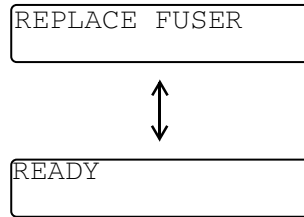

- ⚠ The fusing unit and the parts around it are *hot!* Be sure to wait until the fusing unit has cooled down sufficiently before replacing the fusing unit.
If you touch the hot parts, you might get injured.

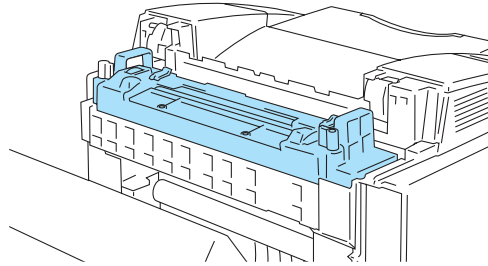

Replacing the fusing unit

- 1 Turn off the printer power switch. To avoid injury, wait until the printer has cooled down sufficiently before you replace the fusing unit.
- 2 Open the back cover of the printer.

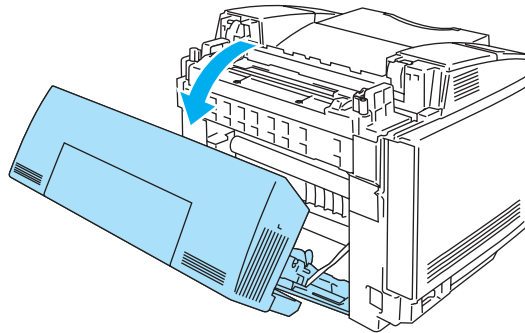

Figure 5-14

- 3 To release the fusing unit from the printer, release the lock levers that are on both sides of the fusing unit as shown in Figure 5-15.

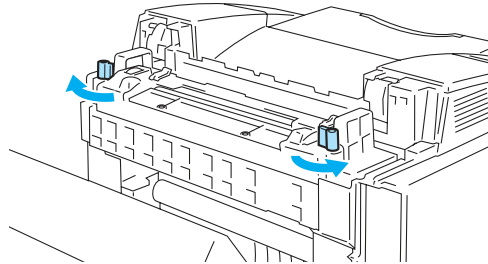

Figure 5-15

- 4 Hold the handles on both sides as you take the fusing unit out of the printer.

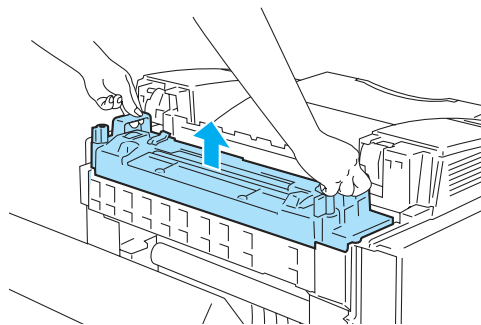

Figure 5-16

- 5 Put the new fusing unit into the printer. Be sure to insert the fusing unit completely into the printer.

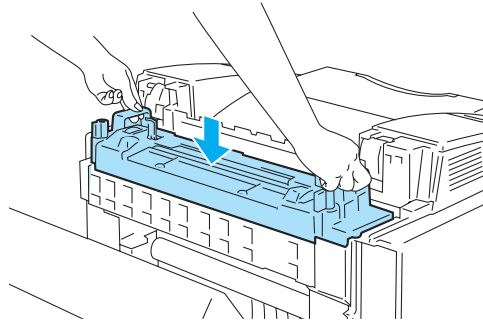

Figure 5-17

- 6 Secure the fusing unit with the two lock levers that are on both sides of the fusing unit.

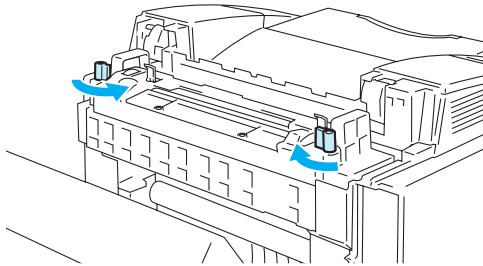

Figure 5-18

- 7 Move the fusing unit pressure release levers to the Set position.

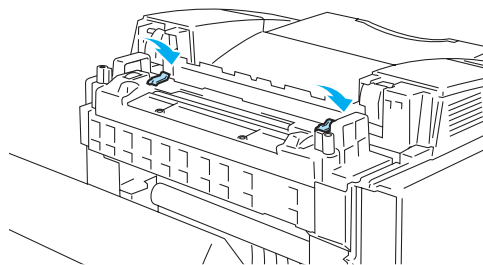

Figure 5-19

- 8 Close the back cover.
- 9 Turn the printer power switch back on.
- 10 Press any of the **Menu** buttons (+, -, **Set** or **Back**) to take the printer off line.
- 11 Press + or - until `RESET MENU` appears.
- 12 Press **Set** to proceed to the next menu level, and then press + or - until `PARTS LIFE` appears.
- 13 Press **Set**, and then press + until `FUSER UNIT` appears.
- 14 Press **Set**. The printer is now in the READY state.

⚠ Please be careful when replacing the fusing unit. Do not put pressure on the fusing unit; it should go in easily. If it does not, make sure the fusing unit connector is free to move. Do not apply force! It could damage both the fusing unit and the printer.

120K kit

When you see the following message on the LCD, you must replace the items in the 120K kit, which are the transfer belt cleaner, transfer roller, paper pick-up roller, separator pad and transfer belt.



- We recommend that you call your service provider when you see the following message on the LCD panel:

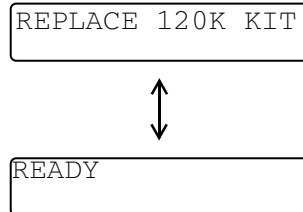

- It is also recommended that your dealer or Brother Customer Service replace the paper pick-up roller, separator pad and transfer belt.
- When you replace the transfer belt cleaner and transfer roller, please follow the instructions. See *Replacing the transfer belt cleaner* on page 5-16 and *Replacing the transfer roller* on page 5-18. Replacement of only the transfer belt cleaner and the transfer roller is not a full 120K service and the counter should not be reset until these additional parts are replaced.

Replacing the transfer belt cleaner



Both ends of the transfer belt cleaner roller consist of metal bearings that connect the bias element to the power supply. These must be connected properly when you install the transfer belt cleaner. Be sure to check how to connect them properly by looking at the old transfer belt cleaner before you begin replacement.

- 1) Turn off the printer power switch.
- 2) Open the top cover of the printer.

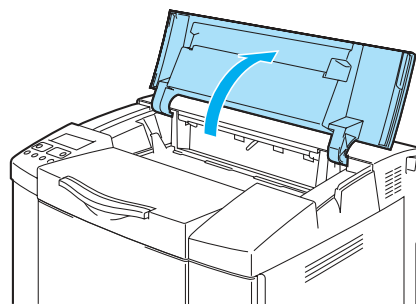

Figure 5-20

- 3) Remove the transfer belt cover.

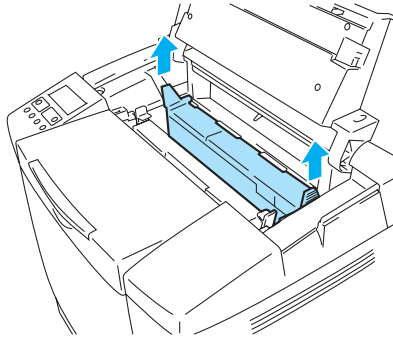

Figure 5-21

- 4) Remove the transfer belt cleaner by grasping the handle and lift it up.

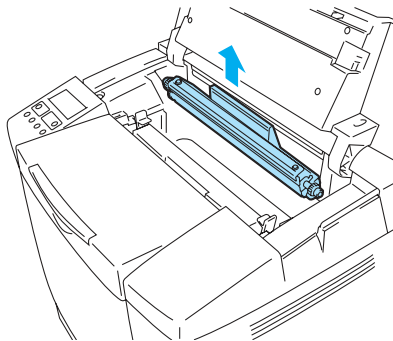

Figure 5-22

- 5) Clean the area where the new transfer belt cleaner is to be installed with a dry cotton cloth.

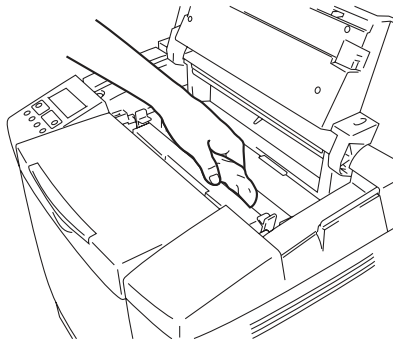

Figure 5-23

- 6) Put the new transfer belt cleaner into the printer by gently placing the brass bearings into the guides, and then pushing the handle down until the bearings click into place. Make sure the transfer belt cleaner is free to move slightly upwards (rotating slightly around the bearings) in

the housing after you have installed it.

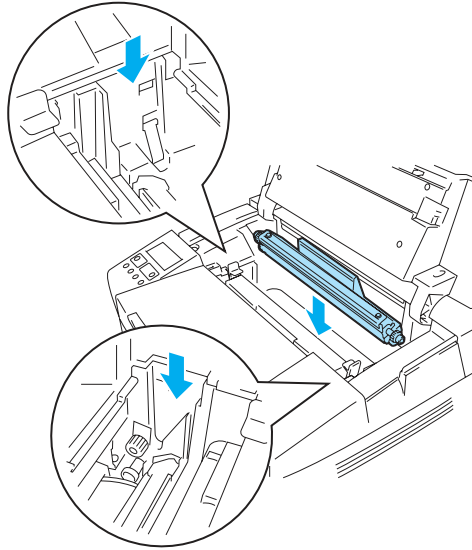



Figure 5-24

- 7) Put the transfer belt cleaner cover back in, and then close the top cover.
- 8) Turn the printer power switch back on.

Replacing the transfer roller

 If you have the duplex unit installed, open the duplex back cover and the duplex inside unit first before you open the back cover of the printer.

- 1) Turn off the printer power switch.
- 2) Open the back cover of the printer.

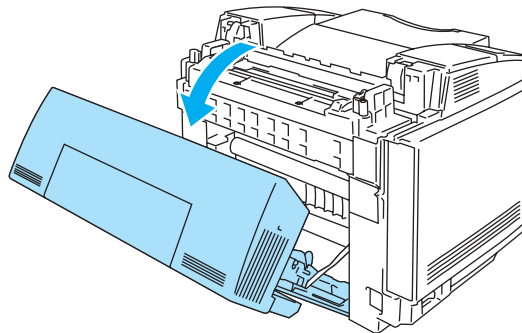

Figure 5-25

- 3) Release the transfer roller lock levers on the right and left-hand sides, and then lift the levers to

release the transfer roller.

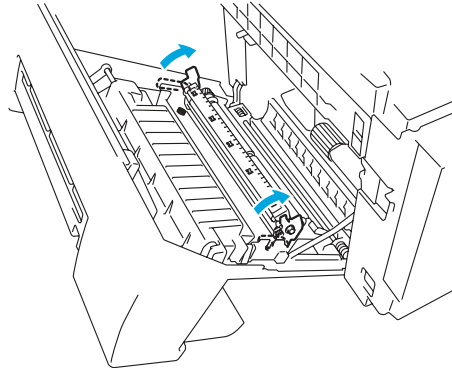

Figure 5-26

- 4) Take out the transfer roller by gently pulling the right-hand side up and sliding the transfer roller to the right.

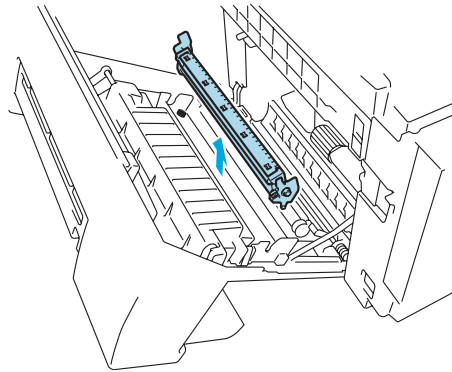

Figure 5-27

- 5) Put in the new transfer roller by holding the lock levers of the transfer roller and adjusting the angle of the transfer roller lever shafts (both sides) to match the transfer unit grooves. Put the transfer roller onto the shafts and place the roller onto the springs as shown below:

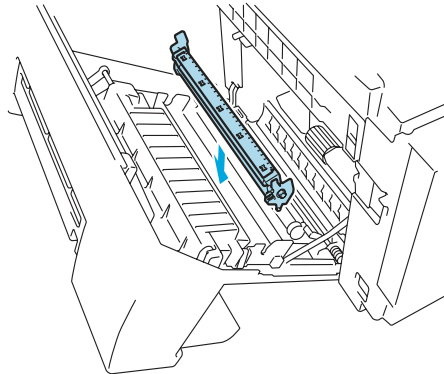

Figure 5-28

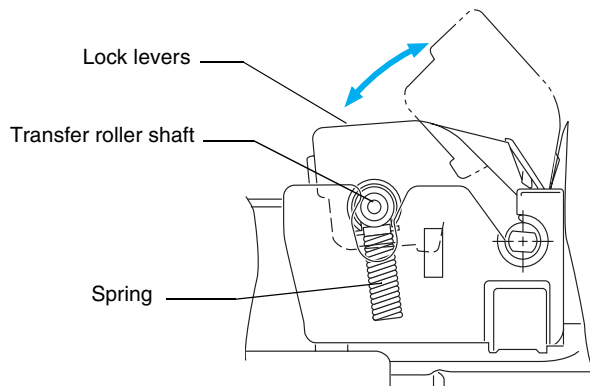

Figure 5-29

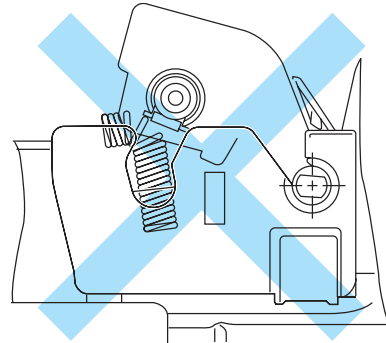

Figure 5-30

- 6) Push the lock levers down to lock the transfer roller into place.
- 7) Close the back cover.
- 8) Turn the printer power switch back on.

Cleaning

Clean the outside and inside of the printer regularly with a dry soft cloth. When you replace the toner cartridge, make sure you clean the inside of the printer. If printed pages are stained with toner, clean the inside of the printer with a dry soft cloth.



- Use *water*. Cleaning with volatile liquids such as thinner or benzine will damage the surface of the printer.
- Do not use cleaning materials that contain ammonia. They could damage the printer, particularly the toner cartridges.

We recommend cleaning the following parts of the printer every 20,000 printed pages or every 12 months:

- Paper guides of the paper tray
- Registration roller
- Paper pick-up roller
- Transfer roller unit
- Transfer roller guide
- Exit roller
- Laser unit
- Dust proof glass

Cleaning the outside of the printer

Clean the outside of the printer as follows:

- 1** Turn off the printer power switch and unplug the printer.
- 2** Take the paper tray out of the printer.
- 3** Wipe the outside of the printer with a soft cloth to remove dust. Dip the cloth in water and wring it out thoroughly for cleaning.

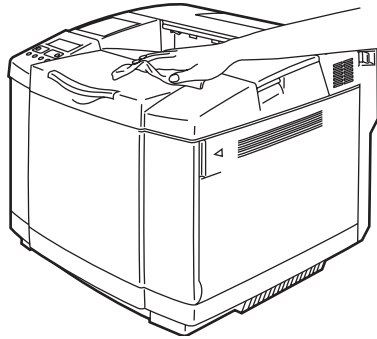

Figure 5-31

- 4** Clean the paper guides of the paper tray with a dry soft cloth. Remove anything that is stuck inside the paper tray.

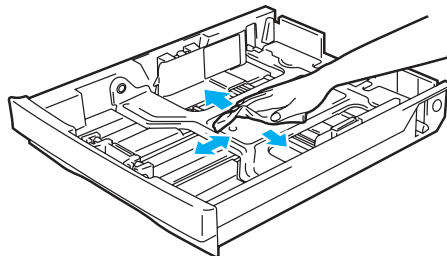



Figure 5-32

- 5** Put the paper tray back in the printer.
- 6** Plug the printer into the AC power outlet/socket, and then turn the printer power switch back on.

Cleaning the inside of the printer

 When you clean the inside of the printer, pay attention to the following:

- If your clothes are smeared with toner, wipe off the toner with a dry cloth. Immediately wash your clothes in cold water to avoid stains.
- The fusing unit and the parts around it are *hot!* Never touch the shaded areas shown below.
- Never touch or clean the transfer roller because print quality may be adversely affected.
- Be careful not to inhale the toner.

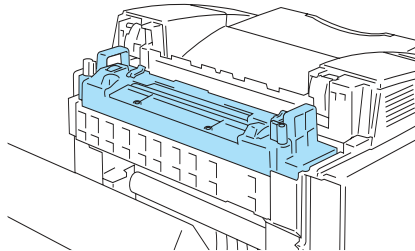

Clean the printer interior as follows:

- 1** Turn off the printer power switch and unplug the printer.
- 2** Open the back cover of the printer.

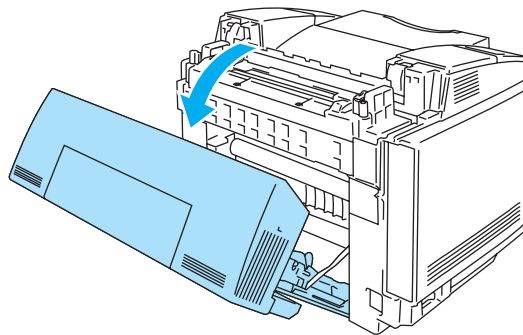

Figure 5-33

- 3** Clean the registration roller and the paper pick-up roller with a dry soft cloth to prevent paper jams.

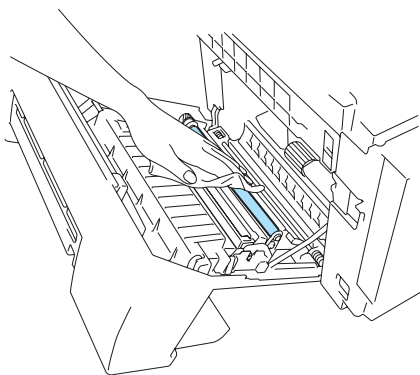

Figure 5-34

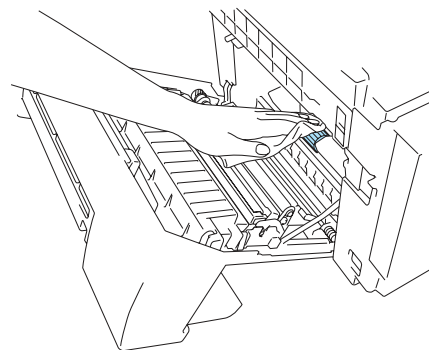

Figure 5-35

- Be careful you do not break the actuator while cleaning the registration roller and paper pick-up roller.
- Make sure you do not put too much pressure on the registration roller and paper pick-up roller. This could damage them and cause poor print quality.

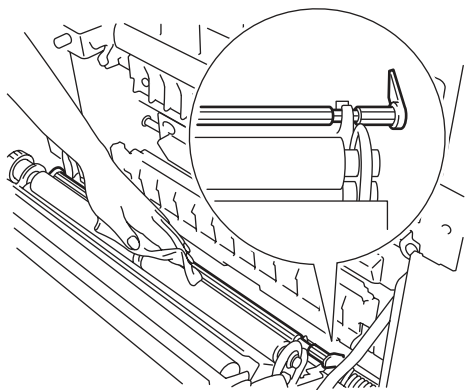

Figure 5-36



Figure 5-37

- 4** Clean the transfer roller unit and the transfer roller guide with a dry soft cloth to prevent paper jams.

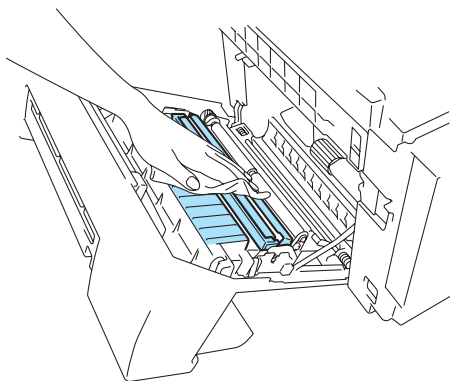

Figure 5-38

- 5** Clean the exit roller. This will help to prevent paper jams at the paper exit and dirt from appearing on your printouts.

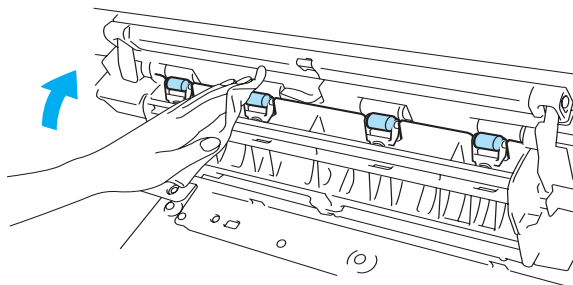

Figure 5-39

- 6** Close the back cover.

7 Open the top cover.

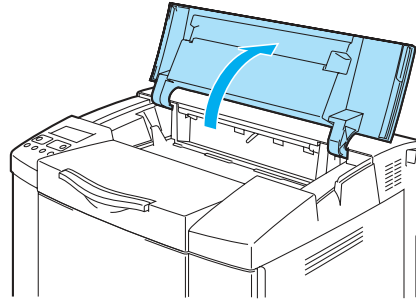

Figure 5-40

8 To release the lock, push the green belt cartridge lock levers that are on both sides inwards.

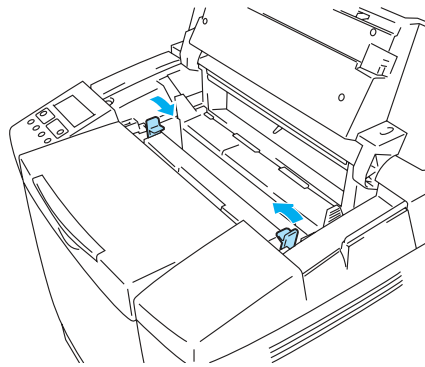

Figure 5-41

9 Remove the OPC belt cartridge from the printer.

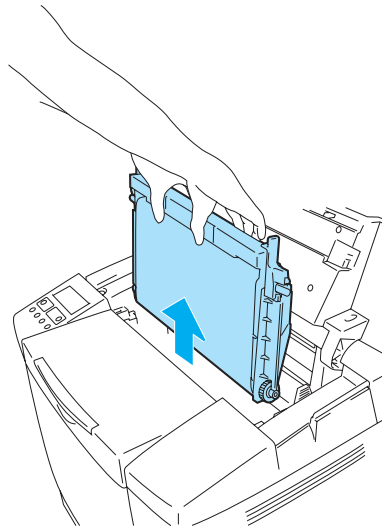

Figure 5-42

10 Place the OPC belt cartridge on a flat surface and cover the shiny green OPC belt with a piece of paper to prevent exposing it to light.



- Do not touch the OPC belt surface with your bare hands or gloves.
- If the belt is exposed for more than two minutes to a light source of 800 lux, the belt could be damaged.

11 Open the front cover of the printer.

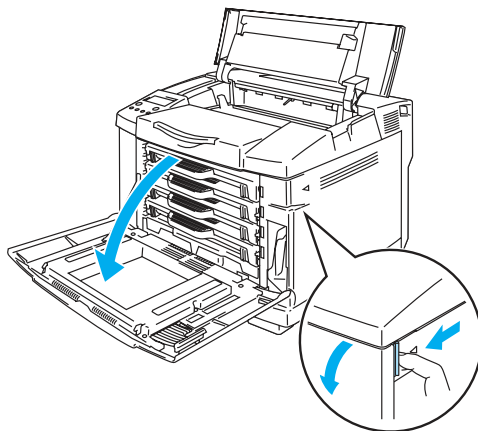

Figure 5-43

12 Take all the toner cartridges out of the printer.

13 Clean the surface of the laser unit with a cotton cloth.

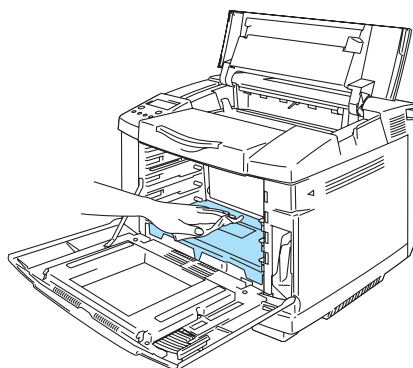

Figure 5-44

14 Open the dust proof glass cover.

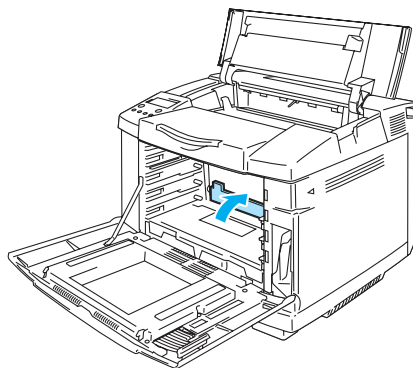

Figure 5-45

15 Clean the surface of the dust proof glass with a dry cotton swab.

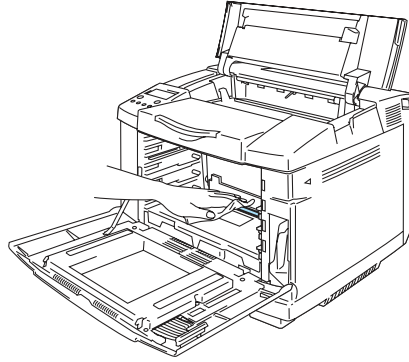

Figure 5-46

! Do not use volatile liquids such as thinner or benzene for cleaning the dust proof glass. This might cause poor print quality.

16 Close the dust proof glass cover.

17 Put all the toner cartridges and the OPC belt cartridge back in the printer.

18 Close the front cover and the top cover.

19 Plug the printer into the AC power outlet/socket, and then turn the printer power switch back on.

! Do not use volatile liquids such as thinner or benzene for cleaning the dust proof glass. This might cause poor print quality.

Shipping the printer

- ▲ ■ Once your printer has been set-up and used, we do not recommend that it be moved or shipped unless absolutely necessary.
- Color laser printers are complex printing devices. Moving the printer or shipping it without properly removing the installed supplies can result in SEVERE damage to the printer. As a result, your printer may not operate properly afterwards.
- If the printer must be shipped, please go to <http://solutions.brother.com> for a detailed, step-by-step instruction on how to properly prepare your printer for transport.
- Failure to properly prepare the printer for shipping according to the instructions located at <http://solutions.brother.com> may VOID YOUR WARRANTY.

6 Troubleshooting

 If you do not follow the instructions for using the printer, you may be responsible for all repairs.

LCD messages

If any problems occur, the printer automatically stops printing, diagnoses the problem, and displays the resulting message on the LCD to alert you. Take the appropriate action, referring to the following tables. If you cannot clear the problem, call the dealer you bought the printer from or Brother Customer Service.



The control panel LCD names for the paper trays are as follows.

- Standard paper tray: TRAY1
- Optional lower tray: TRAY2
- Optional duplex unit: DX





Error messages

When any one of the following messages appear, the printer will stop operating.

Error message	Remarks
TONER EMPTY X Replace the X toner cartridge	X = C, M, Y, K,
NO TONER X Install the X toner cartridge	X = C, M, Y, K,
COVER OPEN Close the Front Cover	
COVER OPEN Close the Top Cover	
COVER OPEN Close the Back Cover	
COVER OPEN Close the Duplex Unit Cover	
JAM X Remove the jammed paper. See the alphanumerical diagram to check on the location	X = A1, A2, B, C, D or E
NO PAPER T1/2 Load paper into Tray 1/2.	
WASTE TONER Replace the waste toner pack.	
NO OPC BELT Install the OPC belt.	Check that the charging roller (on the bottom of the OPC belt cartridge) is locked in place and the levers are closed.
NO TR ROLLER Install the transfer roller.	
ILLEGAL TONER Use only Brother genuine toner cartridges.	

Error message	Remarks
<p>NO TRAY 1/2 The indicated paper tray was not detected,install it, or make sure it is inserted properly.</p>	
<p>SIZE ERROR T2 Specify the correct paper size for the indicated tray.</p>	
<p>SIZE ERROR DX Can only Duplex on specified sizes. Check the printer driver settings and the paper size in the paper tray.</p>	
<p>STACKER FULL Remove the paper from the output tray.</p>	
<p>MEDIA MISMATCH Media mismatch between the Printer and the Printer Driver setting. Put XX in Tray <1/2>.</p>	<p>XX = Plain Paper, Transparencies, Thick Paper, Thicker Paper, Thin Paper</p>
<p>SIZE MISMATCH Put <size> Paper size in Tray <1/2>. Paper mismatch between the Printer and the Printer Driver setting.</p>	
<p>MANUAL FEED Put paper <size> into tray1, and then press GO.</p>	
<p>MEDIATYPE ERROR Specify the correct media type: XX XX=T1, T2, or DX</p>	<p>XX = T1, T2 or DX</p>
<p>NO FUSING UNIT A fusing unit was not detected. Please install one.</p>	
<p>CARD ERROR An error occurred while accessing the Flash card. Check that the driver is formatted and not in Write Protect mode.</p>	
<p>CARD REMOVAL The Flash card was removed while the printer was powered on. Power cycle the printer.</p>	
<p>STORAGE FULL The RAMDISK SIZE is set to 0 MB or there is no more space to store jobs.</p>	
<p>STORAGE FULL There is no space in the CompactFlash.</p>	
<p>DOWNLOAD FULL The download buffer of the printer is full. Add more memory to the printer.</p>	
<p>MEMORY FULL The printer memory is full and the printer is unable to print the page. Add more memory.</p>	

Maintenance messages

Error Message	Meaning	Action
 K C M Y	When the  mark blinks () , the indicated color toner is nearly empty. K: Black, C: Cyan, M: Magenta, Y: Yellow. When the toner becomes empty, the  indicator disappears completely.	Be ready to replace the toner cartridges when the toner is nearly empty. Replace it when the toner becomes empty.
REPLACE OPC BELT	It is time to replace the OPC belt cartridge.	Replace the OPC belt cartridge.
REPLACE FUSER	It is time to replace the fusing unit.	Replace the fusing unit.
REPLACE 120K KIT	It is time to replace the transfer belt cleaner, paper discharger, transfer roller, separator pad, paper pick-up roller and transfer belt.	Call your dealer or Brother Customer Service to replace the transfer belt cleaner, paper discharger, transfer roller, separator pad, paper pick-up roller and transfer belt.
REPLACE PF KIT2	It is time to replace the paper feeding kit 2.	Call your dealer or Brother Customer Service for a replacement of the paper feeding kit 2.
NEAR WASTE TONER	The waste toner pack is almost full.	Replace the waste toner pack.

Call service messages

When any of the following messages appear on the LCD, turn off the printer. Wait a few seconds, and then turn the printer on again. If this does not clear the problem, call your dealer or Brother Customer Service. Tell them the message number for quick troubleshooting.

Call Service Message	Meaning	Action
ERROR S01 SERVICE CALL	Fatal error EX	Turn off the printer. Wait a few seconds, and then turn it on again.
ERROR S02 SERVICE CALL	ADRL error EX	Turn off the printer. Wait a few seconds, and then turn it on again.
ERROR S03 SERVICE CALL	ADRS error EX	Turn off the printer. Wait a few seconds, and then turn it on again.
ERROR S04 SERVICE CALL	Bus error EX (INSTRUCT)	Turn off the printer. Wait a few seconds, and then turn it on again.
ERROR S05 SERVICE CALL	Bus error EX (DATA L/S)	Turn off the printer. Wait a few seconds, and then turn it on again.
ERROR S06 SERVICE CALL	Syscall EX	Turn off the printer. Wait a few seconds, and then turn it on again.
ERROR S07 SERVICE CALL	Breakpoint EX	Turn off the printer. Wait a few seconds, and then turn it on again.
ERROR S08 SERVICE CALL	Reserved INSTRUCT EX	Turn off the printer. Wait a few seconds, and then turn it on again.
ERROR S09 SERVICE CALL	Coprocessor UNUSAB EX	Turn off the printer. Wait a few seconds, and then turn it on again.
ERROR S10 SERVICE CALL	Arithmetic overflow EX	Turn off the printer. Wait a few seconds, and then turn it on again.
ERROR S11 SERVICE CALL	Undefined interrupt	Turn off the printer. Wait a few seconds, and then turn it on again.
ERROR S12 SERVICE CALL	Software 1 interrupt	Turn off the printer. Wait a few seconds, and then turn it on again.
ERROR S13 SERVICE CALL	Software 2 interrupt	Turn off the printer. Wait a few seconds, and then turn it on again.
ERROR S21 SERVICE CALL	Unknown operator call	Turn off the printer. Wait a few seconds, and then turn it on again.
ERROR E41 SERVICE CALL	Engine communication error	Turn off the printer. Wait a few seconds, and then turn it on again.
ERROR H37 SERVICE CALL	PCI register error	Turn off the printer. Wait a few seconds, and then turn it on again.
ERROR H38 SERVICE CALL	PCI bus connection error	Turn off the printer. Wait a few seconds, and then turn it on again.
ERROR H39 SERVICE CALL	BRNET typing error	Turn off the printer. Wait a few seconds, and then turn it on again.
ERROR H60 SERVICE CALL	Bus error	Turn off the printer. Wait a few seconds, and then turn it on again.
ERROR H61 SERVICE CALL	ROM check sum error	Turn off the printer. Wait a few seconds, and then turn it on again.
ERROR H63 SERVICE CALL	DRAM access error	Turn off the printer. Wait a few seconds, and then turn it on again.

Call Service Message	Meaning	Action
ERROR H66 SERVICE CALL	NVRAM write error	Turn off the printer. Wait a few seconds, and then turn it on again.
ERROR H67 SERVICE CALL	NVRAM read error	Turn off the printer. Wait a few seconds, and then turn it on again.
ERROR H68 SERVICE CALL	NVRAM bus error	Turn off the printer. Wait a few seconds, and then turn it on again.
ERROR H73 SERVICE CALL	Flash read error	Turn off the printer. Wait a few seconds, and then turn it on again.
ERROR H74 SERVICE CALL	Flash write error	Turn off the printer. Wait a few seconds, and then turn it on again.
ERROR EC3 WARNING	NVRAM ERROR	Turn off the printer. Wait a few seconds, and then turn it on again.
ERROR EC4 WARNING	Engine controller hardware error	Turn off the printer. Wait a few seconds, and then turn it on again.
ERROR EC7 WARNING	Process timing clock error	Turn off the printer. Wait a few seconds, and then turn it on again.
ERROR ED1 WARNING	Yellow switching clutch error	Turn off the printer. Wait a few seconds, and then turn it on again.
ERROR ED2 WARNING	Magenta switching clutch error	Turn off the printer. Wait a few seconds, and then turn it on again.
ERROR ED3 WARNING	Cyan switching clutch error	Turn off the printer. Wait a few seconds, and then turn it on again.
ERROR ED4 WARNING	Black switching clutch error	Turn off the printer. Wait a few seconds, and then turn it on again.
ERROR ED5 WARNING	Yellow switching solenoid error	Turn off the printer. Wait a few seconds, and then turn it on again.
ERROR ED6 WARNING	Magenta switching solenoid error	Turn off the printer. Wait a few seconds, and then turn it on again.
ERROR ED7 WARNING	Cyan switching solenoid error	Turn off the printer. Wait a few seconds, and then turn it on again.
ERROR ED8 WARNING	Black switching solenoid error	Turn off the printer. Wait a few seconds, and then turn it on again.
ERROR EE1 WARNING	Developing motor error	Turn off the printer. Wait a few seconds, and then turn it on again.
ERROR EE2 WARNING	Main motor error	Turn off the printer. Wait a few seconds, and then turn it on again.
ERROR EE3 WARNING	Transfer belt error	Turn off the printer. Wait a few seconds, and then turn it on again.
ERROR EE5 WARNING	Transfer roller solenoid error	Turn off the printer. Wait a few seconds, and then turn it on again.
ERROR EE6 WARNING	Transfer belt cleaning solenoid error	Turn off the printer. Wait a few seconds, and then turn it on again.
ERROR EE8 WARNING	Fusing unit clutch error	Turn off the printer. Wait a few seconds, and then turn it on again.
ERROR EE9 WARNING	Belt marker sensor error	Turn off the printer. Wait a few seconds, and then turn it on again.
ERROR EEL WARNING	Erase LED error	Turn off the printer. Wait a few seconds, and then turn it on again.

Call Service Message	Meaning	Action
ERROR EF0 WARNING	Cooling fan error	Turn off the printer. Wait a few seconds, and then turn it on again.
ERROR EF3 WARNING	Laser fan error	Turn off the printer. Wait a few seconds, and then turn it on again.
ERROR EF4 WARNING	Fuser fan error	Turn off the printer. Wait a few seconds, and then turn it on again.
ERROR EF5 WARNING	Charger HV unit error	Turn off the printer. Wait a few seconds, and then turn it on again.
ERROR EF6 WARNING	LVPS error	Turn off the printer. Wait a few seconds, and then turn it on again.
ERROR EH0 WARNING	Fuser thermistor error	Turn off the printer. Wait 15 minutes, and then turn it on again.
ERROR EH1 WARNING	Fuser heater error	Turn off the printer. Wait 15 minutes, and then turn it on again.
ERROR EH2 WARNING	Fuser temperature low error at warming up	Turn off the printer. Wait 15 minutes, and then turn it on again.
ERROR EH3 WARNING	Fuser temperature low error	Turn off the printer. Wait 15 minutes, and then turn it on again.
ERROR EH4 WARNING	Fuser temperature high error	Turn off the printer. Wait 15 minutes, and then turn it on again.
ERROR EHA WARNING	Fuser AC OFF error	Turn off the printer. Wait 15 minutes, and then turn it on again.
ERROR EN1 WARNING	Duplex connection error 1	Turn off the printer. Wait a few seconds, and then turn it on again.
ERROR EN2 WARNING	Duplex connection error 2	Turn off the printer. Wait a few seconds, and then turn it on again.
ERROR EN3 WARNING	HVU connection error	Turn off the printer. Wait a few seconds, and then turn it on again.
ERROR EN4 WARNING	Toner empty sensor connection error 1	Turn off the printer. Wait a few seconds, and then turn it on again.
ERROR EN5 WARNING	Toner empty sensor connection error 2	Turn off the printer. Wait a few seconds, and then turn it on again.
ERROR EN6 WARNING	LFU connection error	Turn off the printer. Wait a few seconds, and then turn it on again.
ERROR EL1 WARNING	Beam detector error	Turn off the printer. Wait a few seconds, and then turn it on again.
ERROR EL2 WARNING	Scanner motor error	Turn off the printer. Wait a few seconds, and then turn it on again.
ERROR ELL WARNING	Laser power error	Turn off the printer. Wait a few seconds, and then turn it on again.
ERROR EP1 WARNING	Duplex controller hardware error 1	Turn off the printer. Wait a few seconds, and then turn it on again.
ERROR EP2 WARNING	Duplex controller hardware error 2	Turn off the printer. Wait a few seconds, and then turn it on again.
ERROR EP4 WARNING	Duplex motor error	Turn off the printer. Wait a few seconds, and then turn it on again.
ERROR EP5 WARNING	Outer pass select solenoid error	Turn off the printer. Wait a few seconds, and then turn it on again.

Paper jams and how to clear them

If paper jams inside the printer, the printer will stop. One of the following LCD messages will appear to tell you where to find the jammed paper.

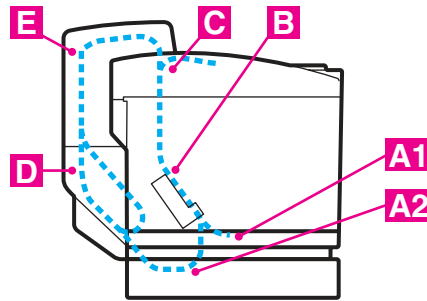

Figure 6-1

JAM A1	Paper jam in the standard paper tray (TRAY1)
JAM A2	Paper jam in the optional lower tray (TRAY2)
JAM B	Paper jam at the entrance to the fusing roller.
JAM C	Paper jam where the paper comes out of the printer.
JAM D	Paper jam in the lower assembly of the duplex unit
JAM E	Paper jam in the upper assembly of the duplex unit

Paper may jam in the paper tray, inside the printer, at the back cover, or where the paper comes out of the printer. Check where the jam is and follow the instructions on the next few pages to remove the jammed paper.

If the error message still appears on the LCD after you remove the jammed paper, there may be more paper jammed somewhere else. Please check the printer thoroughly.

After you have followed the instructions, the printer will resume printing automatically. However, the Status LED may come on and the following message may appear on the display:

PAUSE

After a paper jam has occurred, data usually stays in the printer memory. The message prompts you to do a form feed to print the data that is left. Press **Go** to continue.

- Do not touch the toner surface of the jammed paper. It might stain your hands or clothes.
- After removing the jammed paper, and the next printed page is stained with toner, print several test pages before restarting your print job.
- Remove the jammed paper carefully to prevent spreading toner.
- Take care not to stain your hands and clothes. Wash toner stains immediately with cold water.
- Never touch the transfer roller.
- If the paper in the paper tray is creased at the edges, paper jams can occur. To prevent this, please turn the paper over.



Do not use the following paper:

- Bent/curled paper
- Moist paper
- Paper that does not meet specifications

JAM A1 / JAM A2 (paper jam in the paper tray)

JAM A1

JAM A2

If there is a paper jam in the paper tray, follow these steps:

- 1 Pull out the paper tray.
- 2 Take out the jammed paper.

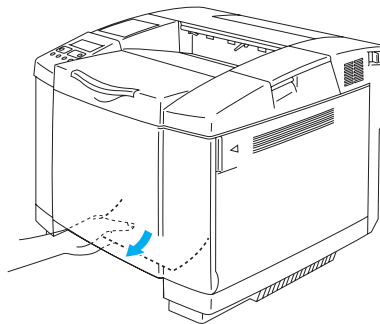

Figure 6-2

- 3 Put the paper tray back in the printer.
- 4 Open the back cover. If there is any jammed paper where the paper comes out, remove it.
- 5 Close the back cover.

JAM B (paper jam at the entrance to the fusing roller)

JAM B

If there is a paper jam at the entrance to the fusing roller, follow the same steps to remove the jammed paper as for *JAM C* (paper jam where the paper comes out of the printer). Otherwise, follow the steps below:

⚠ The fusing roller is extremely hot during operation. Remove the paper carefully.

 If you have the duplex unit installed, open the duplex back cover and then duplex inside unit first before open the back cover of the printer.

- 1 Open the back cover.
- 2 Remove the jammed paper by holding it with both hands and pulling it slowly toward you.

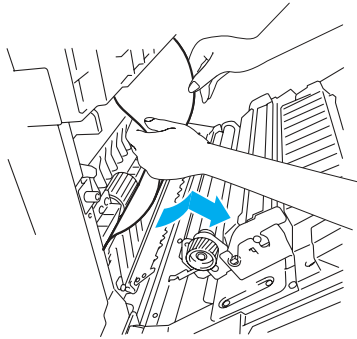

Figure 6-3

- 3 If the paper is caught in the registration roller, remove the jammed paper by holding it with both hands and pulling it slowly toward you.

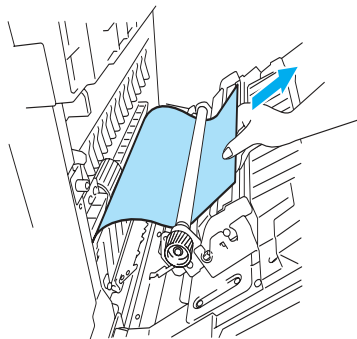

Figure 6-4

If the paper is caught in the fusing roller, follow the steps below:

- 4 Open the back cover.

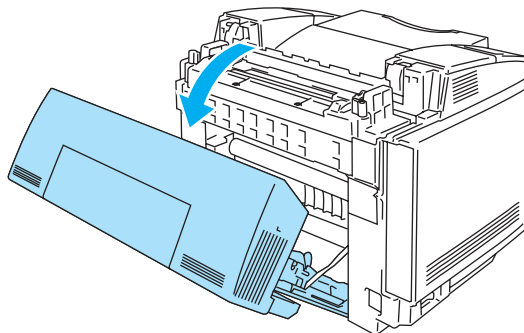

Figure 6-5

- 5 Release the fusing unit pressure release levers on both sides.

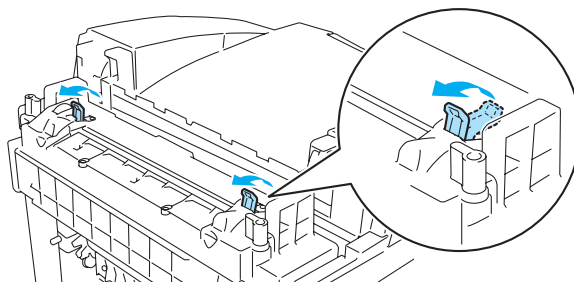

Figure 6-6

- 6 Remove the jammed paper at the back of the printer by holding it with both hands and pulling it slowly toward you.

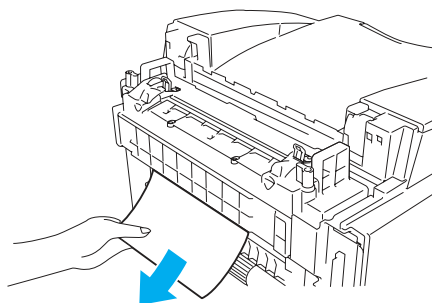
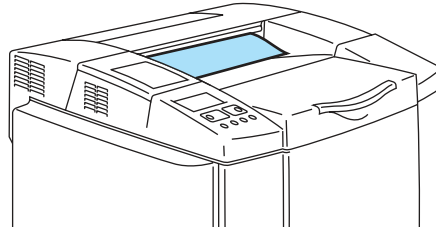

Figure 6-7

- 7 Lock the fusing unit pressure release levers and close the top cover.
- 8 Close the back cover.

JAM C (paper jam where the paper comes out of the printer)

JAM C



If paper has passed behind the back cover and there is a paper jam where the paper comes out, follow the steps below:

 If you have the duplex unit installed, open the duplex back cover and then the duplex inside unit first before opening the back cover of the printer.

- 1 Open the back cover and release the fusing unit pressure release levers.

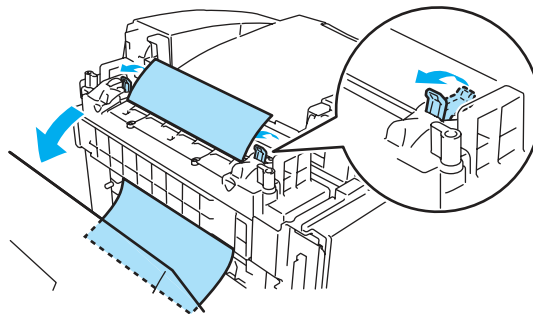

Figure 6-8

- 2 Remove the jammed paper by pulling it out slowly.

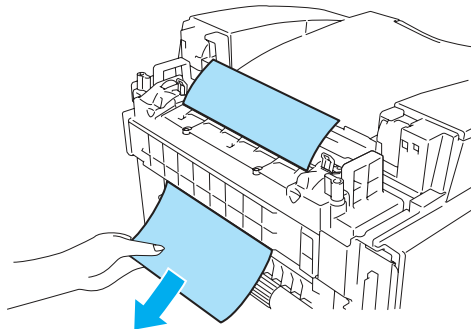

Figure 6-9

3 Reset the fusing unit pressure release levers.

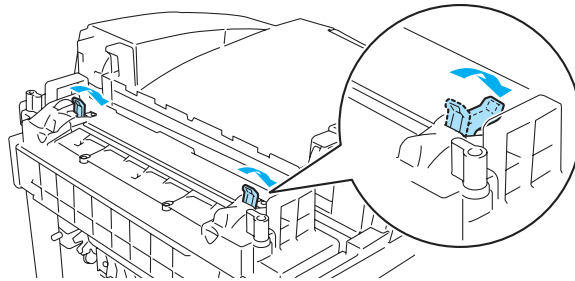

Figure 6-10

4 Close the back cover.

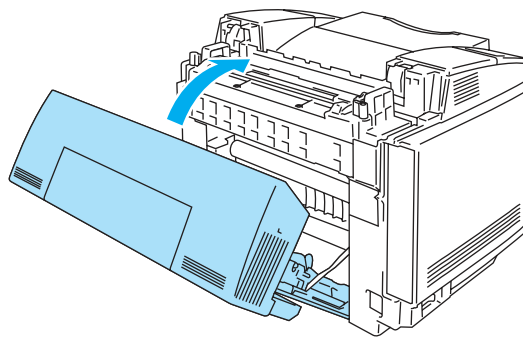

Figure 6-11

JAM D (paper jam in the lower part of the duplex unit)

JAM D

If there is a paper jam in the lower part of the duplex unit, follow these steps:

- 1 Open the duplex back cover.

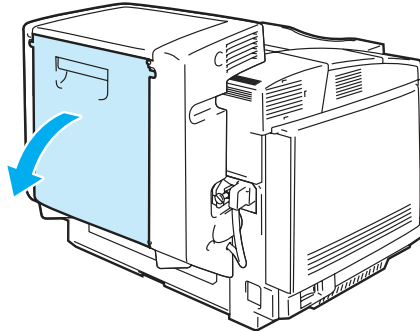

Figure 6-12

- 2 Remove the jammed paper by pulling it out slowly.

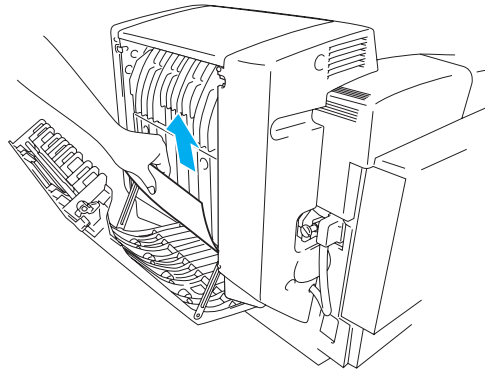

Figure 6-13

- 3 Close the duplex back cover.

JAM E (paper jam in the upper part of the duplex unit)

JAM E

If there is a paper jam in the upper part of the duplex unit, follow these steps:

- 1 Open the duplex back cover.

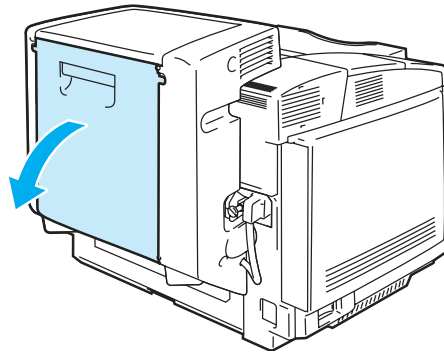

Figure 6-14

- 2 Open the duplex inside unit.

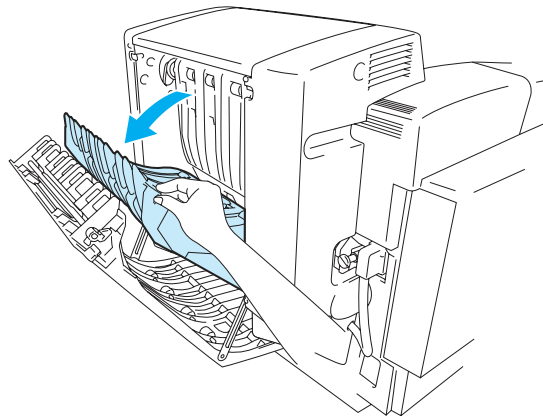

Figure 6-15

- 3** If the paper is caught in the lower exit of the duplex unit, remove the jammed paper by pulling it out slowly.

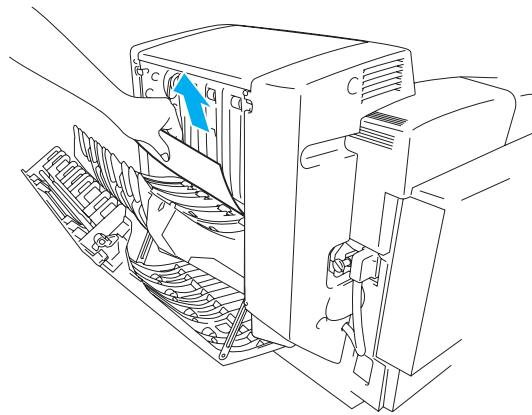

Figure 6-16

- 4** If the jammed paper is at the upper exit of the duplex unit, remove it by rotating the green pinch roller downwards to feed the paper out through the exit of the unit.

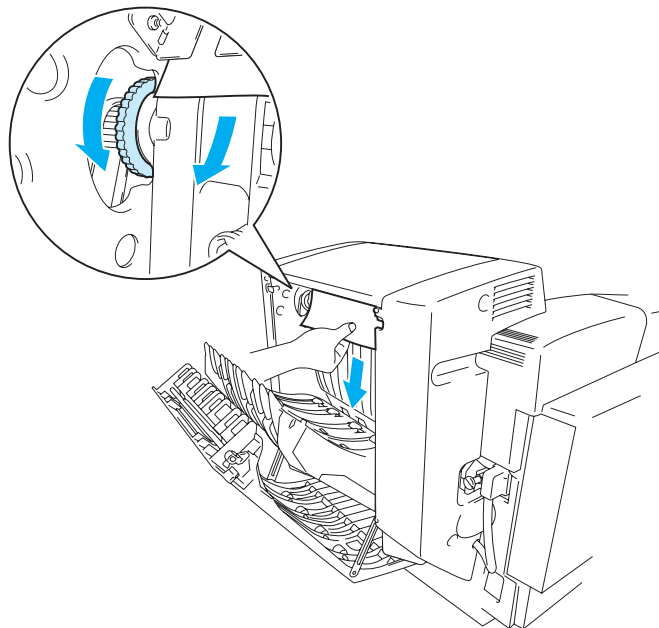





Figure 6-17



- 5** Close the duplex inside unit and the duplex back cover.



Improving the print quality

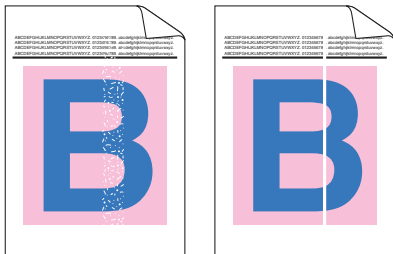
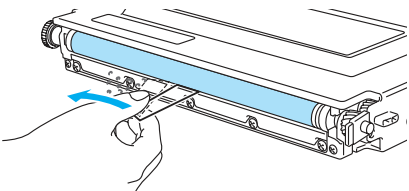

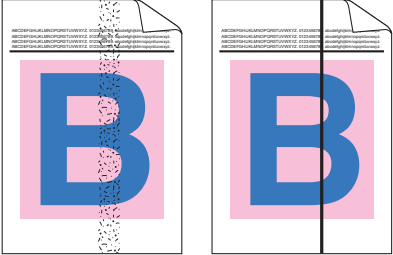
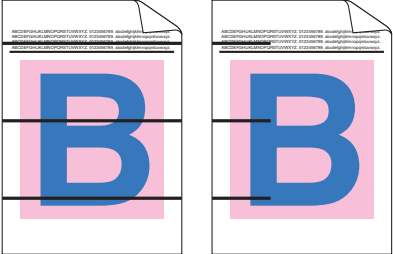
If you are having problems with print quality, please do a test print first (press the **Set** button 3 times). If the problem appears on the printout, then match it to one of the examples below and follow the recommendation. If the problem does not appear on the test print, please check driver settings and the interface cables as the problem may not lie with printer.

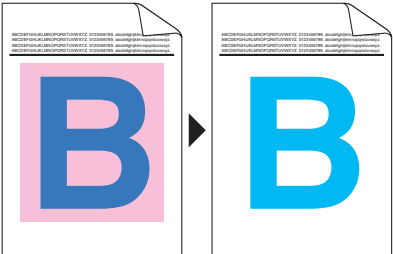
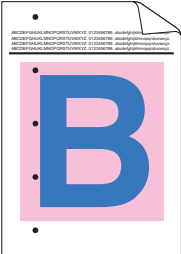
 You can resolve a print quality problem by replacing a toner cartridge with a new one when the toner indicators start blinking or the LCD shows the **TONER EMPTY** message.

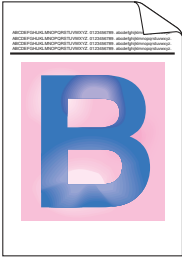
Examples of poor print quality	Recommendation
<p>White lines or bands or ribbing across the page</p> 	<ol style="list-style-type: none"> 1) Check that the printer is on a solid level surface. 2) Check that the back cover is closed properly. 3) Check that the toner cartridges are installed properly. 4) Shake the toner cartridges gently. 5) Check that the transfer roller is installed properly. 6) Replace the transfer roller.
<p>Colors are light or unclear on the whole page</p> 	<ol style="list-style-type: none"> 1) Check that the recommended paper was used. 2) Change the paper to freshly unpacked paper, and then check that the problem is solved. 3) Check that the back cover is closed properly. 4) Shake the toner cartridges gently. 5) Clean the scanner dust glass.
<p>White streaks or bands down the page</p> 	<p>Clean the dust proof glass. Identify the missing color and replace that toner cartridge. *The toner has probably reached the end of its life. However, when you see a white vertical line on the toner roller, try the following procedure.</p> <ol style="list-style-type: none"> 1) Cut a sheet approx. 50mm x 50mm out of a transparency film. 2) Insert the film about 10mm into the gap between the toner roller and the blade. 3) Slide the film and pull it out as shown below. 

Examples of poor print quality	Recommendation
<p>Colored streaks or bands down the page</p> 	<ol style="list-style-type: none"> 1) Identify the missing color and replace that toner cartridge. 2) Replace the OPC belt cartridge.
<p>Colored lines across the page</p> 	<p>Identify the missing color and replace that toner cartridge.</p>
<p>White spots or hollow print</p> 	<ol style="list-style-type: none"> 1) Change the paper to freshly unpacked paper, and then check that the problem was solved. 2) Check that the recommended paper was used. 3) Check that the room temperature is higher than 10 °C (50 °F)
<p>Completely blank or some colors are missing</p> 	<ol style="list-style-type: none"> 1) Check that the back cover is closed properly. 2) Check that the front cover is closed properly. 3) Identify the missing color and check that the toner cartridge is installed properly. 4) Replace the toner cartridge. 5) Replace the OPC belt cartridge.
<p>Colored spots or Toner stain</p> 	<p>Replace the toner cartridge.</p>

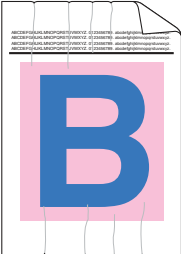
Examples of poor print quality	Recommendation
<p>Toner scatter or toner stain</p> 	<ol style="list-style-type: none"> 1) Identify the color causing the problem and replace that toner cartridge. 2) Replace the OPC belt cartridge.
<p>The color of your printouts are not what you expected</p>	<ol style="list-style-type: none"> 1) Check that the toner cartridges are installed properly. 2) Check that the toner cartridges are not empty. 3) Perform the calibration. see 3-11. 4) Adjust the color by using the custom setting in the driver and by using the control panel. Colors the printer can display and colors you see on a monitor are different. The printer may not be able to reproduce the colors on your monitor. See 3-11. 5) Check to make sure the recommended paper was used.
<p>All one color</p>	<p>Replace the OPC belt cartridge.</p>
<p>Shade on the transparency</p> 	<ol style="list-style-type: none"> 1) Change to the recommended type of transparency, and then check that the problem is solved. 2) Check that the media type mode is selected properly
<p>Color mis-registration</p> 	<ol style="list-style-type: none"> 1) Check that the OPC belt cartridge is installed properly. 2) Check that the cleaning roller is installed properly. 3) Replace the OPC belt cartridge. 4) Replace the cleaning roller.
<p>Uneven density appears periodically across the page</p> 	<ol style="list-style-type: none"> 1) Check that the toner cartridges are installed properly. 2) Check that the OPC belt cartridge is installed properly. 3) Check that the cleaning roller is installed properly. 4) Check that the back cover is closed properly. 5) Check that the fusing unit is installed properly. 6) Replace the OPC belt cartridge.
<p>Missing image at edge</p>	<ol style="list-style-type: none"> 1) Check that the toner cartridges are installed properly. 2) Check that the OPC belt cartridge is installed properly. 3) Replace the toner cartridge. 4) Replace the OPC belt cartridge.

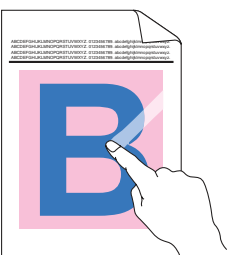
Examples of poor print quality	Recommendation
<p>Wrinkle</p> 	<ol style="list-style-type: none"> 1) Change to a recommended type of paper, and then check that the problem is solved. 2) Check that the back cover is closed properly. 3) Check that the transfer roller is installed properly. 4) Check that the fusing unit is installed properly. 5) Replace the fusing unit.
<p>Mixed color image</p> 	<ol style="list-style-type: none"> 1) Check that the front cover is closed properly. 2) Check that the toner cartridges are installed properly. 3) Check that the transfer roller is installed properly. 4) Replace the toner cartridges.
<p>Insufficient gloss</p>	<p>Check that the recommended paper is being used.</p>
<p>Offset image</p> 	<p>Check that the recommended paper is being used.</p>
<p>Poor fixing</p> 	<ol style="list-style-type: none"> 1) Check that the recommended paper is used. 2) Check that the media type mode is selected properly. 3) Check that the release lever of fusing unit is selected properly. 4) Replace the fusing unit.
<p>Poor fixing when printed on thick paper</p>	<p>Set the printer to thick paper mode through the control panel or the printer driver.</p>

If the same problem occurs again, call your dealer or Brother Customer Service.

Q & A

You may occasionally encounter a difficulty with your HL-2700CN printer. This section contains frequently asked questions and the answers. Find your question below, and then follow the recommended steps. You can correct most problems yourself.

Setting up the printer hardware

Question	Recommendation
The printer does not come on.	Check the following: <ul style="list-style-type: none">■ The printer is securely plugged into the AC power outlet/socket.■ The power source is active.■ The power switch is on.
The printer does not print.	Check the following: <ul style="list-style-type: none">■ The printer is turned on.■ The printer is online.■ All of the protective parts have been removed.■ All the covers on the printer are closed.■ The toner cartridges are installed properly.■ The TONER EMPTY message is not displayed on the LCD. If one or more toner indicators are on, replace those toner cartridges.■ The interface cable is securely connected between the printer and computer.■ If the Alarm LED is blinking: See <i>Error messages</i> on page 6-1.■ The HL-2700CN printer is selected in the printer settings in your application.■ The host is configured properly: check printer port, print manager, etc. (clear stored job or 'use print manager' is turned off)■ There is no jammed paper inside the printer.■ Paper is in the paper tray.■ An error message is not displayed.

Setting up the printer

Question	Recommendation
I cannot print from my application software.	<ul style="list-style-type: none"> ■ Make sure that the supplied Windows® printer driver is installed properly and selected in your application software.
I cannot print the entire page.	<ul style="list-style-type: none"> ■ Check that the size of paper in the feeder is the same as the paper size you selected in your application or in the printer driver. ■ Check that the interface cable is connected to the printer and computer securely.
Computer indicates a device time-out.	<ul style="list-style-type: none"> ■ If the Alarm LED is blinking, clear it and then try to print again. See <i>LCD messages</i> on page 6-1 under <i>Error messages</i>. ■ If the Alarm LED is off, wait a short while and then click the Retry button in the PC screen dialog box. ■ Check that the printer is on line.
Computer indicates paper is empty.	Paper is empty. Put paper in the feeder, and then press Go to recover from the error status.
Computer indicates off line	Press Go to put the printer in the Ready state.
Computer indicates power is off	Check that the printer is securely plugged into the AC power outlet/socket and that the power switch is on.
Computer indicates an error message other than above.	Check the following; <ul style="list-style-type: none"> ■ The computer can work in bi-directional mode. ■ The printer port is correct. ■ Selection of the printer is correct. ■ Recommended interface cable is being used. (IEEE 1284 compliant) Or, select the Control tag in the driver and set the Status Monitor to off.

Paper handling

Question	Recommendation
The printer does not feed paper.	<ul style="list-style-type: none"> ■ Check to see if the Alarm LED is on. If so, the paper tray may be out of paper or not properly inserted. If it is empty, put a new stack of paper in the paper tray. ■ If there is paper in the paper tray, make sure that it is straight. If the paper is curled, you should straighten it before printing. Sometimes it is helpful to remove the paper, turn the stack over, and then put it back in the paper tray. ■ Reduce the stack of paper in the paper tray, and then try again.
How can I load envelopes?	You can feed envelopes from the paper tray (Tray 1). Make sure you adjust the paper guide. Your application software also must be set up properly to print on the size of envelopes you are using. This is usually done in the Page Setup or Document Setup menu of your software. See your applications manual for more information.
Which paper can I use?	See <i>What kind of paper can I use?</i> on page 1-10 for detailed paper specifications.
How can I clear paper jams?	See <i>Paper jams and how to clear them</i> on page 6-7.
The printer feeds more than one sheet at a time.	Check the following: <ul style="list-style-type: none"> ■ The paper in the tray is all the same type. ■ The paper meets the specifications. ■ Paper stack was fanned before loading. ■ The stack of paper is not too high. ■ The side guide is not set too tight.
Paper skews while feeding.	Check the following: <ul style="list-style-type: none"> ■ The side guide is adjusted properly. ■ The amount of paper you loaded is correct. See <i>Paper specifications</i> on page A-4.
Sometimes mis-picking of paper from the paper tray or mis-feeding of paper from the paper exit occurs.	Clean the paper guide, the registration roller and the exit roller. See <i>Cleaning</i> on page 5-21.

Printing

Question	Recommendation
The printer prints unexpectedly or it prints incorrect characters.	<ul style="list-style-type: none">■ Cancel the print job from your computer. Then, turn the printer off and on, or reset the printer and try your print job again.■ Make sure your application software is properly set up to use this printer. Check the printer driver settings or printer settings in your application software.
The computer hangs up when the printer starts printing, or an application error occurs.	Check to see that the system resources are enough (PC memory, etc.). When you have many applications open, the system resources of your PC will not be enough and will cause your PC to hang up. Close applications you are not using and try again.
The headers or footers appear when I view my document on the screen but do not show up when I print them.	Most laser printers have a restricted area that cannot be printed. Adjust the top and bottom margins in your document to allow for this.
Printing takes too long.	<ul style="list-style-type: none">■ Color graphic images contain a large amount of data and the printer will take a relatively long time to complete printing.■ When you print in Super Fine mode, the printer will take a relatively long time to finish printing.■ When the Status LED is blinking, the printer is getting ready to print. Print speed depends on memory size or performance of your PC and memory size of the printer.
The printer doesn't print in color.	<ul style="list-style-type: none">■ The printer may be set to monochrome mode.

A Appendix

Printer specifications

Printing

Print method	Electrophotography by semiconductor laser beam scanning	
Laser	Wavelength	780 nm
	Output	5 mW max.
Resolution	600 dpi class 600 dpi class with CAPT 600 x 600 dpi 600 x 600 dpi with CAPT (The resolution can be enhanced to 2400 dpi class by using CAPT (Color Advanced Photoscale Technology) and Brother exclusive HRC (High Resolution Control))	
Print speed	Standard	Up to 31 ppm (A4/Letter size in monochrome) UP to 8 ppm (A4/Letter size in full color)
	Duplex	Up to 14.5 ppm (A4/Letter size in monochrome) Up to 4 ppm (A4/Letter size in full color)
Warm up time	Less than 45 seconds at 22 °C/71.6 °F (ambient) and AC power of 120 V or 240 V (120 V or 220/240 V models respectively).	
First print	Monochrome	13 seconds or less (A4/Letter size by face down print delivery from standard paper tray)
	Full Color	19 seconds or less (A4/Letter size by face down print delivery from standard paper tray)
Consumable items	Toner in a single color single-component cartridge Life Expectancy: 10,000 (Black), 6,600 (Cyan, Magenta and Yellow) single-sided pages/cartridge (A4/Letter size paper with about 5% coverage).	
Resident printer fonts	PCL	66 scalable fonts, 12 bitmapped fonts, 13 barcode fonts
	BR-Script	35 fonts
	Option	BS-3000 (Upgradable up to PS 165 fonts), BT-1000

Features

CPU	MIPS TMPR4955 (300 MHz)	
Emulation	Automatic emulation selection PCL5C and PCL 6 BR-Script3 HP-GL EPSON FX850 IBM Proprinter XL	
Interface	Automatic interface selection among IEEE 1284 Parallel, 10/100BASE-TX Ethernet, Hi-Speed USB 2.0	
Network connectivity	Interface	10/100 Base TX Ethernet (Auto Negotiation)
	Protocol	TCP/IP ARP, RARP, BOOTP, DHCP, APIPA (Auto IP), WINS/NetBIOS, DNS, LPR/LPD, Custom Raw Port/Port9100, POP3/SMTP, SMB Print, IPP, FTP, SSDP, TELNET, SNMP, HTTP, TFTP Netware IPX/SPX (Bindery/NDS) AppleTalk DLC/LLC NetBEUI
	Management tool	BRAdmin Professional, Web Based Management, Web BRAdmin
RAM	64 MB (Expandable up to 576 MB with SO-DIMMs) The printer's standard memory can vary depending on the printer model and country.	
Storage device	CompactFlash® memory (Microdrive™ is not compatible.)	
Control panel	6 buttons, 2 LEDs and one LCD that is a 2-line, 16-column display	
Diagnostics	Self-diagnostic program	

Electrical and mechanical

Power Source	U.S.A. and Canada	AC 120 V, 50/60 Hz
	Europe and Australia	AC 220 to 240 V, 50/60 Hz
Power consumption	Printing (Average)	670 W or less
	Stand-by	200 W or less
	Stand-by in sleep mode	35 W or less
Noise	Printing	LWAd = 6.6 bels or less
	Stand-by	LWAd = 5.4 bels or less
Temperature	Operating	10 to 32.5°C (50°F to 90.5°F)
	Non-operational	5 to 35°C (41°F to 95°F)
	Storage	0 to 35°C (38°F to 95°F)
Humidity	Operating	20 to 80% (without condensation)
	Storage	10 to 90% (without condensation)
Dimensions (W x D x H)	480 (W) x 420 (D) x 385 (H) mm (18.9 x 16.4 x 15.2)	
	480 (W) x 470 (D) x 535 (H) mm (18.9 x 18.5 x 21.1 in.) with an optional lower tray unit installed	
	480 (W) x 525 (D) x 590 (H) mm (18.9 x 20.7 x 23.2 in.) with installed optional lower tray unit and optional duplex unit	
Weight	Approx. 31.5 kg (69.4 lb)	
	Approx. 42.7 kg (94.1 lb) with optional lower tray unit, optional duplex unit and toner cartridges installed	

Paper specifications

Paper handling

Paper input	Standard paper tray (Tray 1)	Up to 250 sheets of 75 g/m ² (20 lb)
	Optional lower tray (Tray 2)	Up to 530 sheets of 75 g/m ² (20 lb)
	Optional legal tray (Tray 1)	Up to 250 sheets of 75 g/m ² (20 lb)
Paper output	Face-down print delivery	Up to 250 sheets of 75 g/m ² (20 lb)

Media specifications

Media types	Standard paper tray	Plain paper, Envelopes, Transparencies, Labels, Thick paper
	Optional lower tray	Plain paper, Thick paper
	Optional legal tray	Plain paper, Envelopes, Transparencies, Labels, Thick paper
	Optional duplex unit	Plain paper, Thick paper
Media weights	Standard paper tray	60 to 210 g/m ² (16 to 55 lb)
	Optional lower tray	60 to 105 g/m ² (16 to 28 lb)
	Optional legal tray	60 to 210 g/m ² (16 to 55 lb)
	Optional duplex unit	60 to 105 g/m ² (16 to 28 lb)
Media sizes	Standard paper tray	A4, Letter, B5 (JIS/ISO), Executive, A5, COM10, DL 104.8 x 210 mm to 215.9 x 297 mm (4.1 x 8.3 in. to 8.5 x 11.7 in.)
	Optional lower tray	A4, Letter, B5 (JIS/ISO), Executive
	Optional legal tray	Legal, A4, Letter, B5 (JIS/ISO), Executive, A5, COM10, DL 104.8 x 210 mm to 215.9 x 355.6 mm (4.1 x 8.3 in. to 8.5 x 14 in.)
	Optional duplex unit	A4, Letter, Legal, B5 (JIS/ISO), Executive, A5 148 x 210 mm to 215.9 x 355.6 mm (5.8 x 8.3 in. to 8.5 x 14 in.)

INDEX

- button3-2, 3-3

Symbols

+ button3-2, 3-3

Numerics

120K kit5-16

A

Accessories and supplies vi

Accessories tab2-8

Alarm LED3-5

Automatic emulation selection1-6, 2-19

Automatic interface selection1-6, 2-20

B

Back button3-2, 3-4

Barcode font4-16

Belt cartridge lock lever5-10

BRAdmin Professional utility2-18

Brother Solutions Center2-1

BR-Script3-16

BR-Script3 mode3-21

Buttons3-2

C

Call service messages6-4

Color Advanced Photoscale Technology (CAPT)

.....1-5

CompactFlash4-11

Consumable items5-1

Control panel3-1, 3-7

Control panel LCD menu3-9

D

Data compression1-6

Date and time setting3-19

Delete storage3-12

Device options2-5

Duplex2-4

Duplex unit (optional)4-7

E

Emulation mode3-21

Envelopes1-15

EPSON FX-850 mode3-21

Error messages6-1

F

Factory settings3-22, 3-23

Fusing unit5-13

G

Go button3-2

H

High Resolution Control (HRC)1-5

HP LaserJet mode3-21

HP-GL mode3-21

I

IBM Proprinter XL mode3-21

INFORMATION menu3-10

INTERFACE menu3-17

IP address3-16, 3-20, 3-25

J

Job Cancel button3-2

L

Labels1-17

LCD (liquid crystal display)3-1, 3-6

LED (light-emitting diode)3-5

legal tray (optional)1-10, 4-5

Lower tray unit4-2

lower tray unit1-10

M

Macintosh2-1, 2-16

Maintenance messages6-3

Manual feed1-19

Memory, installing4-14

Menu settings3-2, 3-9

N

NETWORK menu3-16

Network software2-18

O

OPC belt cartridge5-10

P

Paper feed1-18

PAPER menu3-11

paper tray (standard)1-10

Parallel interface2-20

PCL1-6, 3-12, 3-21

PCL printer driver	2-2
Power save mode	1-7
PRINT MENU menu	3-13
Print quality	2-4
Printer driver	2-1, 2-2, 2-10
Printer status messages	3-7
PROOF data	3-28
Protective sheet	5-11
PS printer driver	2-10
PUBLIC data	3-28

Q

QUALITY menu	3-11
--------------------	------

R

Register your printer	v
Reprint	2-6
REPRINT menu	3-18
RESET MENU menu	3-17

S

SECURE data	3-29
Set button	3-2, 3-3
SETUP menu	3-12
SO-DIMM	4-13
Status LED	3-5
Status Monitor	2-6

T

TCP/IP	3-16
Tension release pin	5-11
Toner cartridge	5-4
Toner save mode	1-7
Transfer belt cleaner	5-16
Transfer belt cover	5-17
Transfer roller	5-18
Transfer roller lock lever	5-18
Transparency	1-17
Tray feed	1-18
Troubleshooting	6-1

U

USB interface	2-20
---------------------	------

W

Waste toner pack	5-8
Waste toner pack holder	5-9
Watermark	2-4
Windows	2-1, 2-2, 6-21